

MedioTehna

Measuring instruments and systems

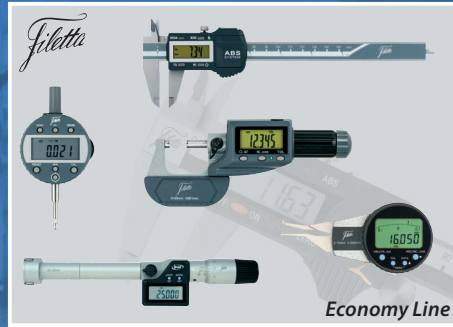

Economy Line

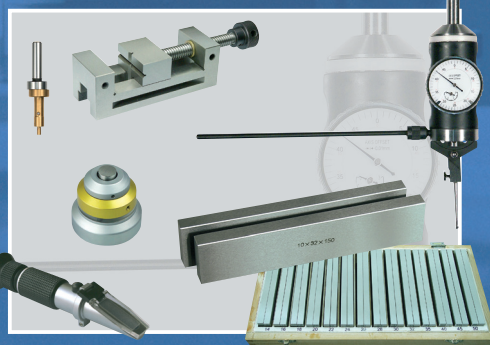
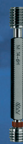

precision measuring instruments
mechanical - optical - electronical

2023/2024

GENERAL CATALOG

Measuring instruments and systems

MedioTehna



ORANICE 107/1
HR - 10 090 ZAGREB

[www. MedioTehna .hr](http://www.MedioTehna.hr)
e-mail : info@mediotehna.hr

Tel : +385 1 2302 726
Fax : +385 1 2302 151

Table of contents

category	page
1 Calipers / Depth calipers and micrometers	4–49
2 Micrometers / Micrometer heads	50–89
3 Internal micrometers / Internal & external measuring instruments	90–126
4 Dial indicators / Dial test indicators / Center instruments Edge finders / Probes	127–157
5 Stands / Bench centers / Surface plates	158–178
6 V-blocks / Vises / Angle plates / Cylindrical squares Squares / Parallels / Straight edges	179–214
7 Protractors / Clinometers / Spirit levels	215–235
8 Roughness specimens	236–238
9 Gauge blocks / Measuring balls / Optical flats and plan parallel optical flats / Feeler gauges	239–256
10 Gauges / Pin gauges / Thread and tolerance tables	257–281
11 Magnifiers / Microscopes / Glass rulers Stereo microscopes / Endoscopes	282–310
12 Graduated rulers / Scale units / Circumference tapes Precision tapes / Distance meters	311–323
13 Scribing tools / Compasses / Center squares	324–331
14 Height and scribing gauges / Height gauges	332–338
15 Hardness testers / (Coating) thickness gauges / (Infrared) thermometers Tachometers / Dynamometers / Inspection instruments	339–358
16 Measuring instrument displays and interfaces	359–362

Calipers / Depth calipers and micrometers



Absolute digital calipers

Calipers with an absolute measuring system for easy incremental and absolute conversion.

- Measuring range: 0-300 mm.
- Resolution: 0.01 mm.
- mm/inch conversion.
- ABS/INC switchable.
- On/off switch.
- Reset.
- Large LCD display.
- Thumb wheel/locking screw/flat depth rod.
- Power supply: 1 battery type V357.

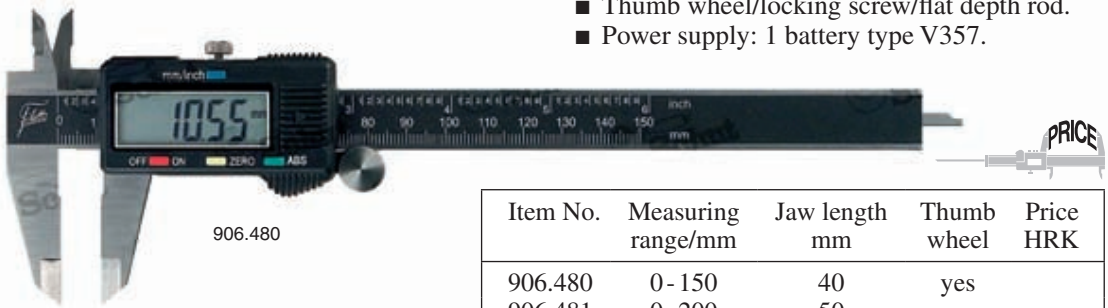

906.480

MedioTehna

Item No.	Measuring range/mm	Jaw length mm	Thumb wheel	Price HRK
906.480	0-150	40	yes	
906.481	0-200	50	yes	
906.482	0-300	60	yes	
Option:				
836.535	Spare battery type V357			

Digital calipers with excellent price-performance ratio

- Measuring range: 0-300 mm.
- Resolution: 0.01 mm.
- mm/inch conversion.
- On/off switch.
- Reset.
- Large LCD display (except 906.483/484).
- Thumb wheel (except 906.299/483/484).
- Locking screw/flat depth rod.
- Power supply: 1 battery type V357.

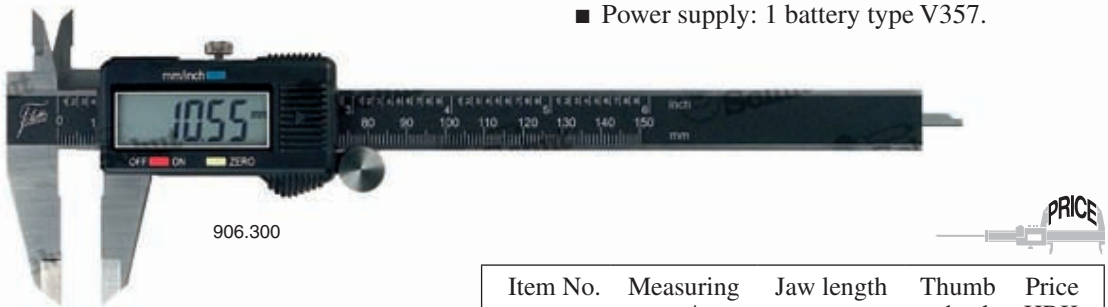

906.300



906.299

Item No.	Measuring range/mm	Jaw length mm	Thumb wheel	Price HRK
906.483	0- 75	30	no	
906.484	0-100	30	no	
906.300	0-150	40	yes	
906.302	0-200	50	yes	
906.304	0-300	60	yes	
Left-handed model:				
906.299	0-150	40	no	
Option:				
836.535	Spare battery type V357			

Absolute digital calipers

Calipers with an absolute measuring system for easy incremental and absolute conversion. The advantage of these calipers is the one-time setting of the absolute zero position until the battery has to be changed. This reduces the chance of measuring errors and enables you to use the calipers without having to reset the zero position at every use.

- Measuring range: 0-300 mm.
- Resolution: 0.01 mm.
- Accuracy: ± 0.03 mm.
- mm/inch conversion.
- ABS/INC switchable.
- On/off switch.
- Automatic switch-off.
- Reset.
- Large LCD display.
- Thumb wheel/locking screw/flat depth rod.
- Delivery in a plastic case with a manufacturer measuring report.
- Power supply: 1 battery type V357.

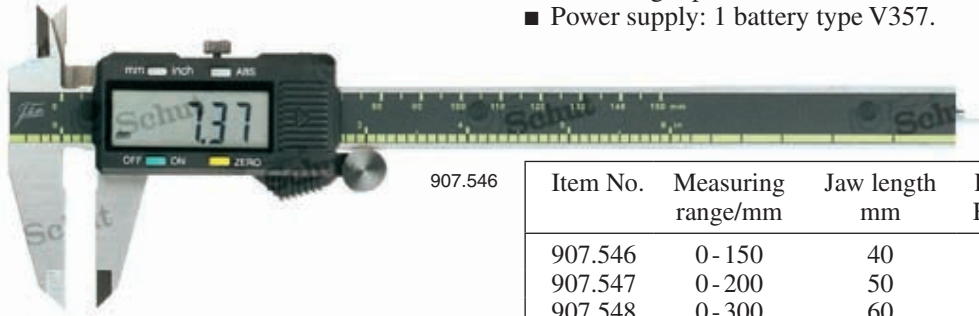

907.546

Item No.	Measuring range/mm	Jaw length mm	Price HRK
907.546	0-150	40	
907.547	0-200	50	
907.548	0-300	60	
Option:			
836.535	Spare battery type V357		



Digital calipers

The advantage of these calipers is the one-time setting of the absolute zero position until the battery has to be changed. This reduces the chance of measuring errors and enables you to use the calipers without having to reset the zero position at every use.

- Measuring range: 0-300 mm.
- Resolution: 0.01 mm.
- Accuracy: ± 0.03 mm.
- mm/inch conversion.
- On/off switch.
- Automatic switch-off.
- Reset.
- Large LCD display.
- Thumb wheel/locking screw/flat depth rod.
- Delivery in a plastic case with a manufacturer measuring report.
- Power supply: 1 battery type V357.

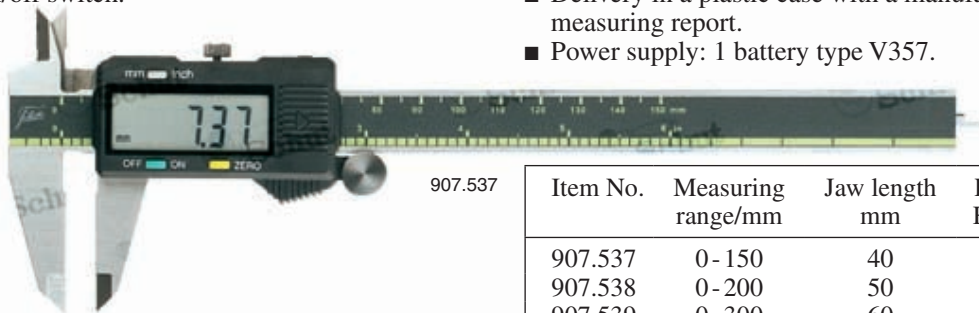

907.537

Item No.	Measuring range/mm	Jaw length mm	Price HRK
907.537	0-150	40	
907.538	0-200	50	
907.539	0-300	60	
Option:			
836.535	Spare battery type V357		

MedioTehna



Digital calipers with hold function

Digital calipers with a function to hold the display value at any position.

- Measuring range: 0-300 mm.
- Resolution: 0.01 mm.
- mm/inch conversion.
- On/off switch.
- Reset.
- Hold function.
- Large LCD display.
- Thumb wheel/locking screw/flat depth rod.
- Power supply: 1 battery type V357.

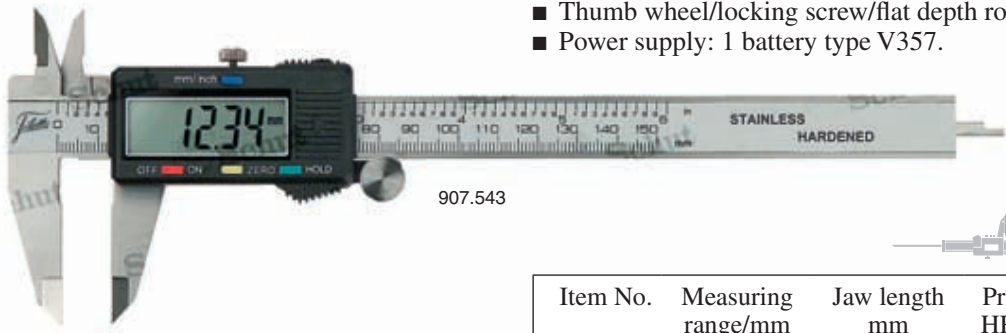

907.543

PRICE

Item No.	Measuring range/mm	Jaw length mm	Price HRK
907.543	0-150	40	
907.544	0-200	50	
907.545	0-300	60	
Option:			
836.535	Spare battery type V357		

Digital calipers with min/max function

By keeping the mode button pressed you can hold the minimum and maximum measuring values.

- Measuring range: 0-300 mm.
- Resolution: 0.01 mm.
- mm/inch conversion.
- On/off switch.
- Reset.
- Min/max function.
- Large LCD display.
- Thumb wheel/locking screw/flat depth rod.
- Power supply: 1 battery type V357.

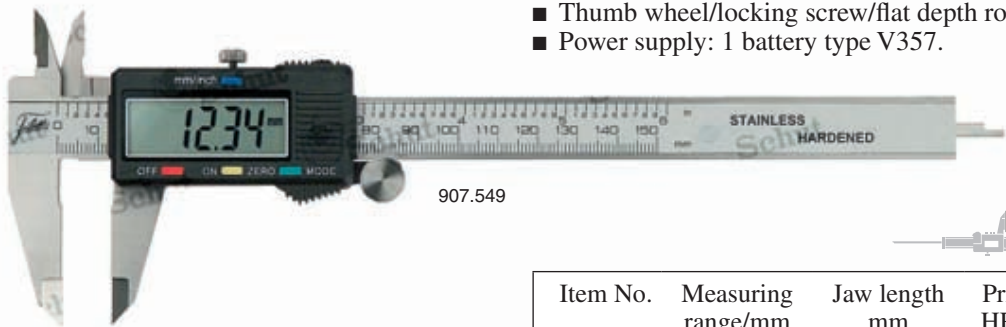

907.549

PRICE

MedioTehna

Item No.	Measuring range/mm	Jaw length mm	Price HRK
907.549	0-150	40	
907.550	0-200	50	
907.551	0-300	60	
Option:			
836.535	Spare battery type V357		

Digital calipers 0.005 mm

Calipers with a higher resolution and a measuring range up to 300 mm.

- Measuring range: 0 - 300 mm.
- Resolution: **0.005 mm**.
- Accuracy: ± 0.03 mm.
- mm/inch conversion.
- ABS/INC switchable.
- On/off switch.
- Automatic switch-off.
- Reset.
- Thumb wheel/locking screw/flat depth rod.
- Power supply: 1 battery type CR2032.

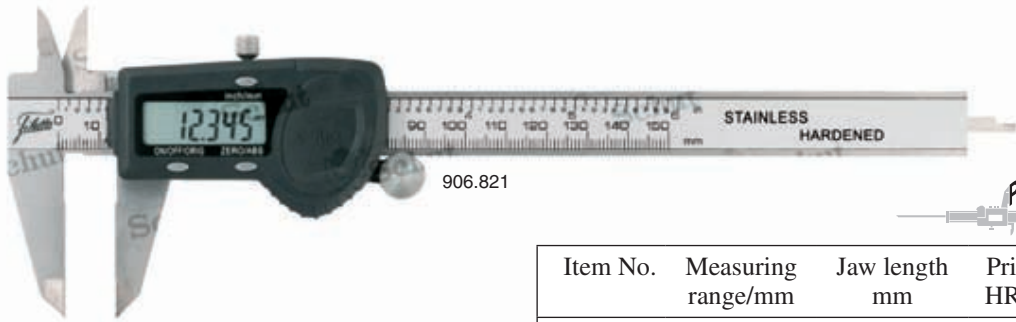

Item No.	Measuring range/mm	Jaw length mm	Price HRK
906.821	0 - 150	40	
906.822	0 - 200	50	
906.823	0 - 300	60	
Option:			
495.157 Spare battery type CR2032			

Digital solar calipers

The solar power supply functions already with a low illumination level.

- Measuring range: 0 - 300 mm.
- Resolution: 0.01 mm.
- mm/inch conversion.
- Automatic switch-off.
- Reset.
- Thumb wheel/locking screw/flat depth rod.
- Back-up power supply (prevents shut-down in dark places): 1 battery type V389.

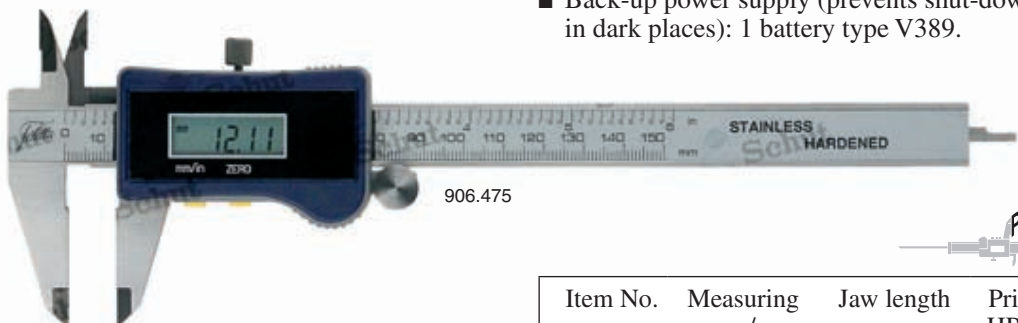

Item No.	Measuring range/mm	Jaw length mm	Price HRK
906.475	0 - 150	40	
906.492	0 - 200	50	
906.493	0 - 300	60	
Option:			
498.823 Spare battery type V389			

MedioTehna

Digital calipers with glass ruler

Equipped with a glass ruler. Very smooth displacement by non-contact movement.

- Measuring range: 0- 300 mm.
- Resolution: 0.01 mm.
- Accuracy: ± 0.03 mm.
- mm/inch conversion.
- ABS/INC switchable (only 909.443/444/445).
- On/off switch.
- Automatic switch-off.
- Reset.
- Large LCD display.
- Thumb wheel/locking screw/flat depth rod.
- Delivery in a plastic case with a manufacturer measuring report.
- Power supply: 1 battery type CR2025.

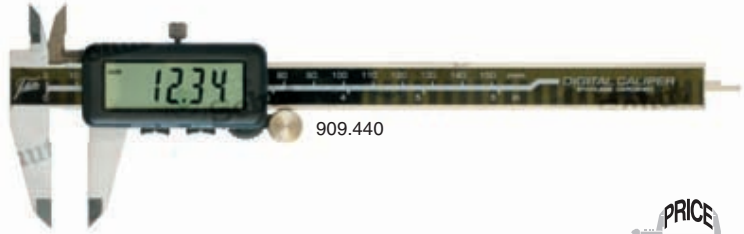

Item No.	Measuring range/mm	Jaw length mm	Price HRK
909.440	0- 150	40	
909.441	0- 200	50	
909.442	0- 300	60	
Absolute calipers:			
909.443	0- 150	40	
909.444	0- 200	50	
909.445	0- 300	60	
Option:			
495.214	Spare battery type CR2025		

Digital calipers with tolerance function

Digital calipers with a function to set tolerance limits with Go/NoGo reading.

- Measuring range: 0- 300 mm.
- Resolution: 0.01 mm.
- Accuracy: ± 0.03 mm.
- mm/inch conversion.
- Tolerance function.
- On/off switch.
- Automatic switch-off.
- Reset.
- Large LCD display.
- Thumb wheel/locking screw/flat depth rod.
- Delivery in a plastic case with a manufacturer measuring report.
- Power supply: 1 battery type CR2025.



Item No.	Measuring range/mm	Jaw length mm	Price HRK
906.412	0- 150	40	
906.413	0- 200	50	
906.414	0- 300	60	
Option:			
495.214	Spare battery type CR2025		

Absolute digital calipers IP54

Calipers with an absolute measuring system for easy incremental and absolute conversion. The advantage of these calipers is the one-time setting of the absolute zero position until the battery has to be changed. This reduces the chance of measuring errors and enables you to use the calipers without having to reset the zero position at every use. These calipers have a protection degree of IP54 and are therefore protected against splash water and resistant to oil and dust. The models with the tolerance limit function are provided with a clear optical Go (NoGo) indication.

- Measuring range: 0 - 300 mm.
- Resolution: 0.01 mm.
- mm/inch conversion.
- ABS/INC switchable.
- With data output.
- On/off switch.
- Automatic switch-off.
- Reset.
- Max. measuring speed: unlimited.
- Locking screw/flat depth rod.
- Protection: IP54.
- Delivery in a plastic case with a manufacturer measuring report.
- Power supply: 1 battery type CR2032.

Models with tolerance display:

- Adjustable tolerance limits.
- Tolerance display by means of illuminated green LED at GO value.

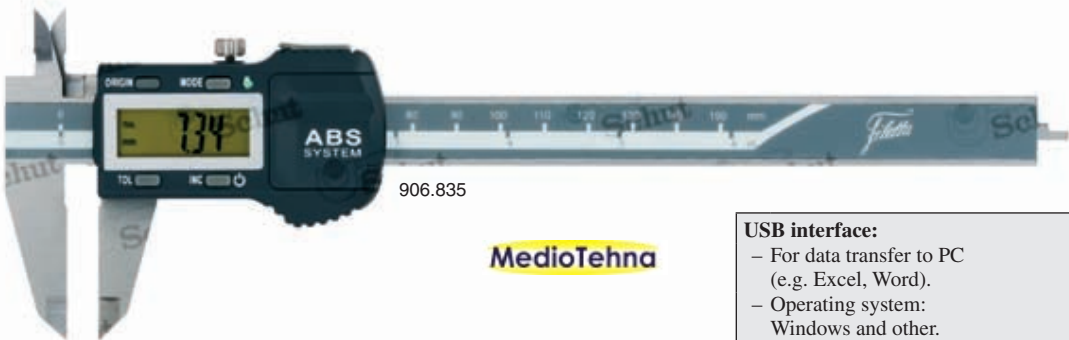

906.835

MedioTehna

PRICE

USB interface:

- For data transfer to PC (e.g. Excel, Word).
- Operating system: Windows and other.
- PC connection: USB.
- No software or driver to install.
- Foot switch (optional).

Item No.	Measuring range/mm	Accuracy mm	Jaw length mm	Price HRK
906.838	0 - 150	0.02	40	
906.839	0 - 200	0.03	50	
906.840	0 - 300	0.03	60	

Models with tolerance display:

906.835	0 - 150	0.02	40
906.836	0 - 200	0.03	50
906.837	0 - 300	0.03	60

Options:

- 495.157 Spare battery type CR2032
- 906.618^{1,2} USB interface
- 909.687 Footswitch for USB interface
- 910.038 Wireless USB receiver
- 906.619² Wireless transmitter



906.618



909.687



906.619/910.038

¹ Standard configured for PC with English (US) keyboard. Also available on request for alternative keyboards.

² With micro-USB connection.

Absolute digital calipers IP54

Calipers with an absolute measuring system for easy incremental and absolute conversion. This gives you the advantage that the caliper stores the one-time setting of the absolute zero position until the battery has to be changed. This reduces the chance of measuring errors and enables you to use the caliper without having to reset the zero point with each use. These calipers have a protection degree of IP54 and are therefore protected against splash water and resistant to oil and dust.

- Measuring range: 0-300 mm.
- Resolution: 0.01 mm.
- mm/inch conversion.
- ABS/INC switchable.
- Digimatic data output.
- On/off switch.
- Reset.
- Max. measuring speed: unlimited.
- Thumb wheel supplied separately.
- Locking screw/flat depth rod.
- Protection: IP54.
- Delivery in a plastic case with a manufacturer measuring report.
- Power supply: 1 battery type CR2032.

MedioTehna

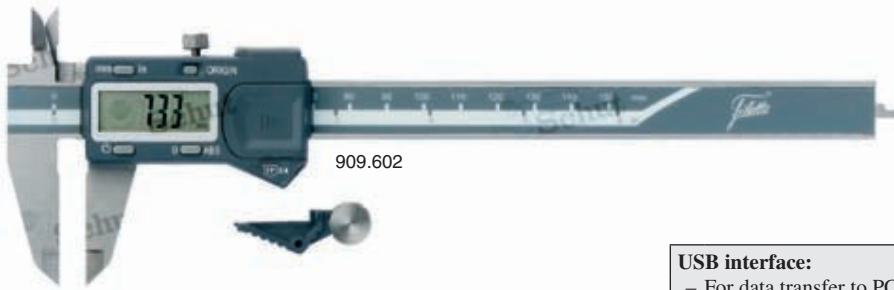

909.602

USB interface:

- For data transfer to PC (e.g. Excel, Word).
- Operating system: Windows and other.
- PC connection: USB.
- No software or driver to install.
- Foot switch (optional).



909.686



909.687



910.039/038



Item No.	Measuring range/mm	Accuracy mm	Jaw length mm	Price HRK
909.602	0 - 150	0.02	40	
909.603	0 - 200	0.03	50	
909.604	0 - 300	0.03	60	

Options:

- 495.157 Spare battery type CR2032
- 909.686^{1,2} USB interface
- 909.687 Footswitch for USB interface
- 910.038 Wireless USB receiver
- 910.039² Wireless transmitter

¹ Standard configured for PC with English (US) keyboard. Also available on request for alternative keyboards.

² For instruments with a Digimatic data output.

Absolute digital calipers IP54

Calipers with an absolute measuring system for easy incremental and absolute conversion. This gives you the advantage that the caliper stores the one-time setting of the absolute zero position until the battery has to be changed. This reduces the chance of measuring errors and enables you to use the caliper without having to reset the zero point with each use. These calipers have a protection degree of IP54 and are therefore protected against splash water and resistant to oil and dust.

- Measuring range: 0- 300 mm.
- Resolution: 0.01 mm.
- mm/inch conversion.
- ABS/INC switchable.
- On/off switch.
- Automatic switch-off.
- Reset.
- Thumb wheel/locking screw/flat depth rod.
- Protection: IP54.
- Delivery in a plastic case with a manufacturer measuring report.
- Power supply: 1 battery type CR2032.



MedioTehna

Item No.	Measuring range/mm	Accuracy mm	Jaw length mm	Price HRK
906.177	0 - 150	0.02	40	
906.178	0 - 200	0.03	50	
906.179	0 - 300	0.03	60	

Option:

495.157 Spare battery type CR2032

Digital calipers IP54

These calipers have a protection degree of IP54 and are therefore protected against splash water and resistant to oil and dust.

- Measuring range: 0- 300 mm.
- Resolution: 0.01 mm.
- mm/inch conversion.
- On/off switch.
- Reset.
- Thumb wheel/locking screw/flat depth rod.
- Protection: IP54.
- Power supply: 1 battery type V357.



Item No.	Measuring range/mm	Jaw length mm	Price HRK
907.900	0 - 150	40	
907.901	0 - 200	50	
907.902	0 - 300	60	

Option:

836.535 Spare battery type V357

Digital carbon fiber calipers

Digital calipers made of carbon fiber.

- Measuring range: 0-300 mm.
- Resolution: 0.1 mm.
- mm/inch conversion.
- On/off switch.
- Automatic switch-off.
- Reset.
- Flat depth rod (only 909.420).
- Power supply:
909.420/688: 1 battery type CR2032,
909.689: 1 battery type V357.

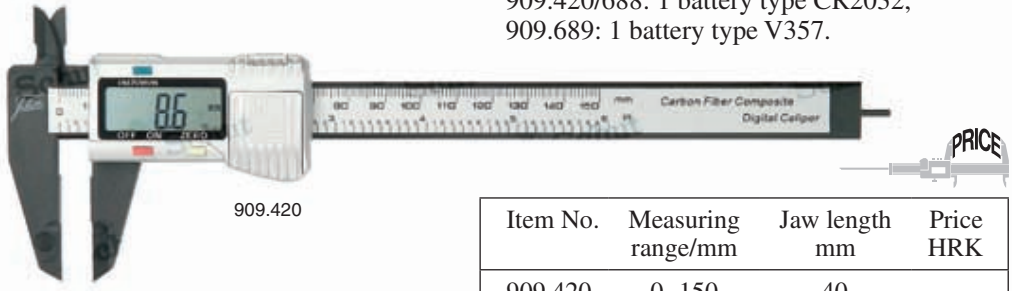

909.420

MedioTehna

Item No.	Measuring range/mm	Jaw length mm	Price HRK
909.420	0-150	40	
909.688	0-150	75	
909.689	0-300	90	

Options:
495.157 Spare battery type CR2032
836.535 Spare battery type V357

Digital calipers IP67

These IP67 protected calipers are especially suitable for use in production environments: they are fully protected against dust intrusion and even temporary immersion.

- Measuring range: 0-300 mm.
- Resolution: 0.01 mm.
- mm/inch conversion.
- Automatic switch-off.
- Reset.
- Large LCD display.
- Thumb wheel/locking screw/flat depth rod.
- Protection: IP67.
- Delivery in a plastic case with a manufacturer measuring report.
- Power supply: 1 battery type CR2032.

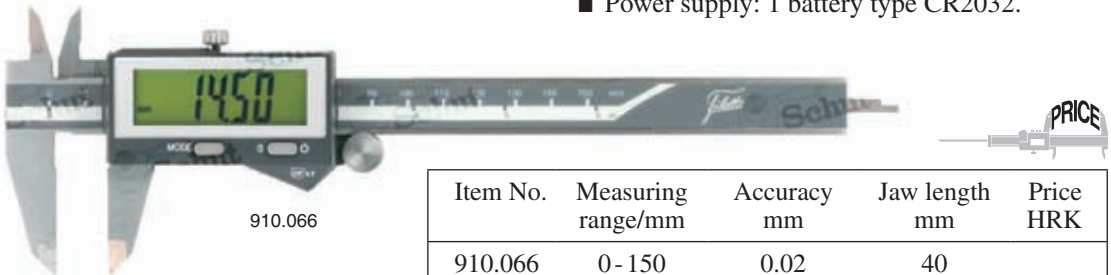

910.066



Item No.	Measuring range/mm	Accuracy mm	Jaw length mm	Price HRK
910.066	0-150	0.02	40	
910.067	0-200	0.03	50	
910.068	0-300	0.03	60	

With Bluetooth:
910.069 0-150 0.03 40

Option:
495.157 Spare battery type CR2032

Absolute digital calipers IP67

These IP67 protected calipers are especially suitable for use in production environments: they are fully protected against dust intrusion and even temporary immersion.

Calipers with an absolute measuring system for easy incremental and absolute conversion. The advantage of these calipers is the one-time setting of the absolute zero position until the battery has to be changed. This reduces the chance of measuring errors and enables you to use the calipers without having to reset the zero position at every use.

- Measuring range: 0 - 300 mm.
- Resolution: 0.01 mm.
- mm/inch conversion.
- ABS/INC switchable.
- On/off switch.
- Automatic switch-off.
- Reset.
- Locking screw/flat depth rod.
- Protection: IP67.
- Power supply: 1 battery type CR2032.

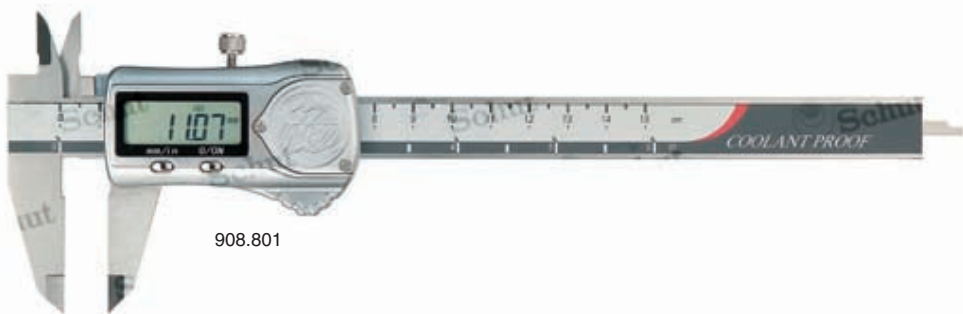

908.801

Item No.	Measuring range/mm	Accuracy mm	Jaw length mm	Price HRK
908.801	0 - 150	0.02	40	
908.802	0 - 200	0.03	50	
908.803	0 - 300	0.03	60	

Option:

495.157 Spare battery type CR2032

Digital calipers with tungsten carbide measuring faces

- Measuring range: 0-300 mm.
- Resolution: 0.01 mm.
- mm/inch conversion.
- On/off switch.
- Reset.
- Large LCD display.
- Thumb wheel/locking screw/flat depth rod.
- Tungsten carbide measuring faces.
- Power supply: 1 battery type V357.

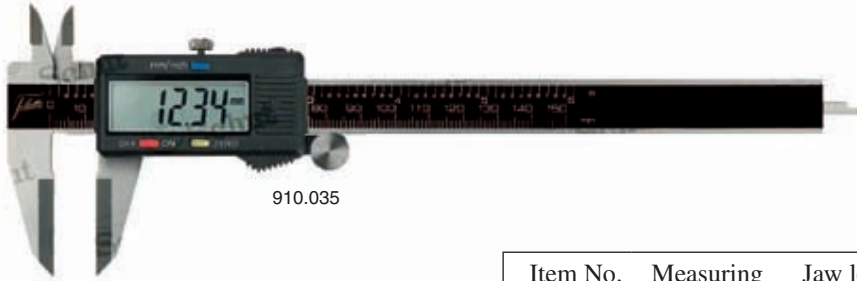

MedioTehna



Item No.	Measuring range/mm	Jaw length mm	Price HRK
910.035	0-150	40	
910.036	0-200	50	
910.037	0-300	60	
Option:			
836.535 Spare battery type V357			

Digital Caliper with long measuring jaw

Digital caliper with long measuring jaw for use as scribing tool.

- Measuring range: 0-150 mm.
- Resolution: 0.01 mm.
- mm/inch conversion.
- On/off switch.
- Reset.
- Large LCD display.
- Locking screw/flat depth rod.
- Tungsten carbide measuring faces.
- Power supply: 1 battery type V357.

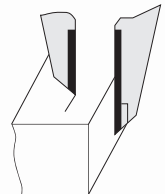

Item No.	Measuring range/mm	Price HRK
910.284	0-150	
Option:		
836.535 Spare battery type V357		

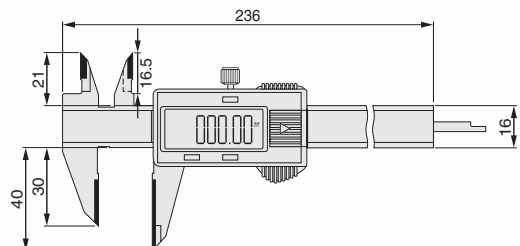

Digital calipers with slidable measuring jaw

For measuring distances between planes at different levels. Very suitable as scribing tool!

- Measuring range: 0 - 500 mm.
- Resolution: 0.01 mm.
- mm/inch conversion.
- On/off switch.
- Reset.
- Large LCD display.
- Thumb wheel/locking screw.
- Power supply: 1 battery type V357 (except 906.348).

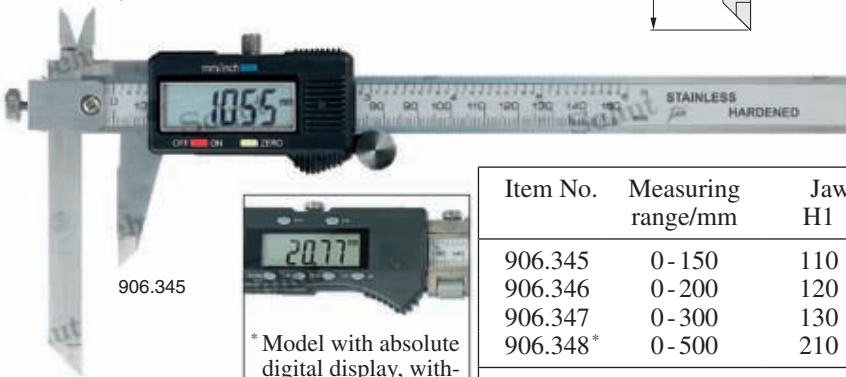
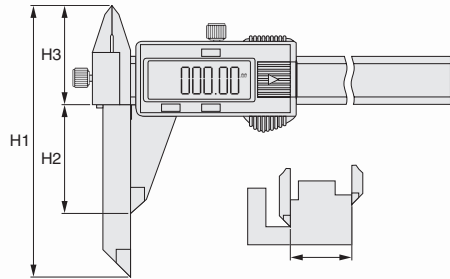

MedioTehna



* Model with absolute digital display, without thumb wheel, with fine adjustment and preset function.

Item No.	Measuring range/mm	Jaw length/mm			Price HRK
		H1	H2	H3	
906.345	0 - 150	110	40	37	
906.346	0 - 200	120	50	40	
906.347	0 - 300	130	60	42	
906.348*	0 - 500	210	100	66	

Options:
 836.535 Spare battery type V357
 495.157 Spare battery type CR2032

Digital calipers for measuring center distances

Suited for measuring center distances between bores from $\varnothing 1$ up to 4.5 mm. Because both measuring jaws are adjustable in height it is possible to measure center distances between bores that are positioned at different levels.

- Measuring range: 5 - 300 mm.
- Resolution: 0.01 mm.
- mm/inch conversion.
- On/off switch.
- Reset.
- Large LCD display.
- Locking screw.
- Power supply: 1 battery type V357.

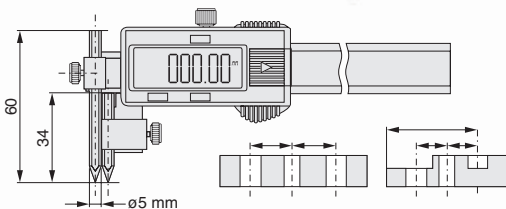

Item No.	Measuring range/mm	Price HRK
906.395	5 - 150	
906.396	5 - 200	
906.397	5 - 300	

Option:
 836.535 Spare battery type V357

Digital caliper with pin-shaped anvil

Digital caliper for measuring e.g. (tube) wall thickness.

- Measuring range: 0- 150 mm.
- Resolution: 0.01 mm.
- mm/inch conversion.
- On/off switch.
- Reset.
- Large LCD display.
- Pin-shaped anvil: $\varnothing 4$ mm.
- Locking screw.
- Power supply: 1 battery type V357.

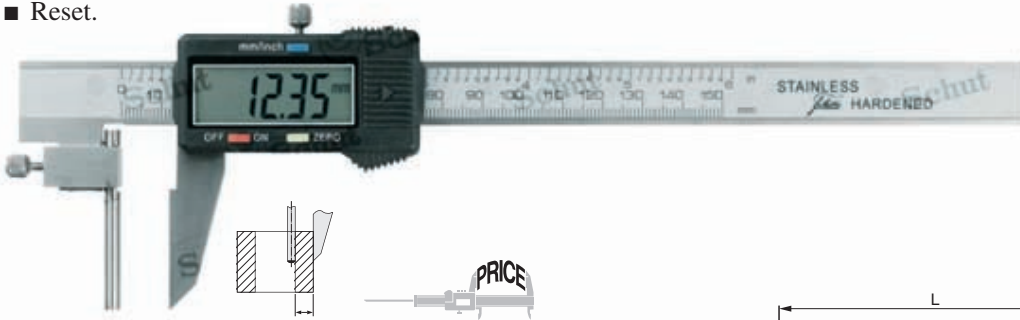

Item No.	Measuring range/mm	a mm	b mm	Price HRK
910.262	0- 150	46	30	
Option:				
836.535 Spare battery type V357				

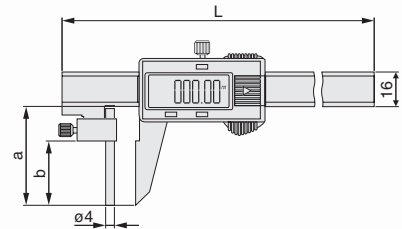

Digital calipers with large measuring faces

Calipers with large rectangular measuring faces for the measurements of for example round shafts and cables.

- Measuring range: 0- 300 mm.
- Resolution: 0.01 mm.
- mm/inch conversion.
- On/off switch.
- Reset.
- Large LCD display.
- Locking screw.
- Power supply: 1 battery type V357.

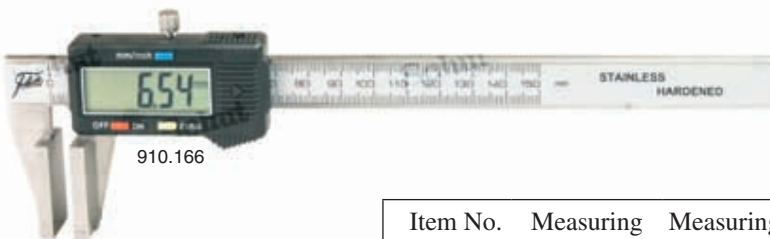

910.166

MedioTehna

Item No.	Measuring range/mm	Measuring face width/mm	Measuring face height/mm	Price HRK
910.166	0- 150	20	30	
910.167	0- 200	30	40	
910.168	0- 300	40	50	
Option:				
836.535 Spare battery type V357				

Digital calipers with pointed measuring jaws

The pointed measuring jaws of these calipers enable you to measure distances in places that are hard to reach.

- Measuring range: 0-300 mm.
- Resolution: 0.01 mm.
- mm/inch conversion.
- On/off switch.
- Reset.
- Large LCD display.
- Thumb wheel/locking screw/flat depth rod.
- Power supply: 1 battery type V357.

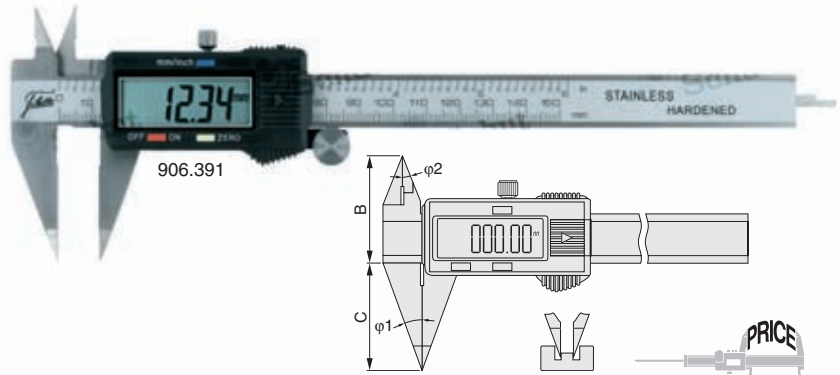

Item No.	Measuring range/mm	Jaw length C/mm	Length B/mm	Angle phi 1	Angle phi 2	Price HRK
906.391	0-150	40	37	20°	20°	
906.392	0-200	50	40	20°	22.5°	
906.393	0-300	60	42	20°	22.5°	
Option:						
836.535 Spare battery type V357						

MedioTehna

Digital calipers with thin measuring jaws

Digital calipers with extra thin measuring jaws for measuring inside small grooves.

- Measuring range: 0-300 mm.
- Resolution: 0.01 mm.
- mm/inch conversion.
- On/off switch.
- Reset.
- Large LCD display.
- Locking screw/flat depth rod.
- Delivery in a case.
- Power supply: 1 battery type V357.



Item No.	Measuring range/mm	Accuracy mm	e mm	f mm	g mm	Price HRK
910.274	0-150	±0.06	20	3.6	0.75	
910.275	0-200	±0.10	20	3.6	0.75	
910.276	0-300	±0.10	20	3.8	1	
Option:						
836.535 Spare battery type V357						

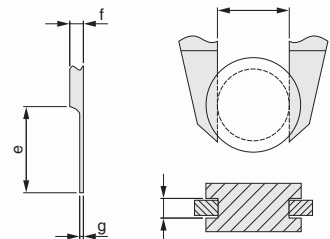

Digital calipers with outside angled measuring pins

These calipers are equipped with outward angled rounded pins.

- Measuring range: 35 - 500 mm.
- Resolution: 0.01 mm.
- mm/inch conversion.
- On/off switch.
- Reset.
- Large LCD display.
- Thumb wheel/locking screw.
- Power supply: 1 battery type V357 (except 906.383).

MedioTehna

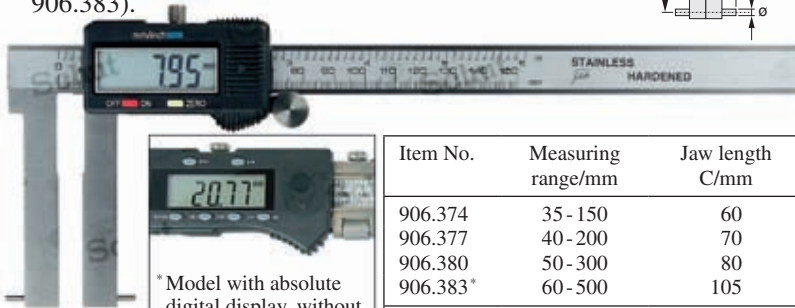
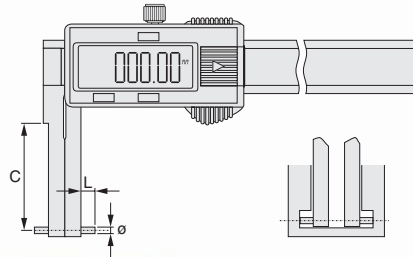

906.374

PRICE

Item No.	Measuring range/mm	Jaw length C/mm	Pin ø/mm	Pin length L/mm	Price HRK
906.374	35 - 150	60	2	6	
906.377	40 - 200	70	3	7	
906.380	50 - 300	80	3	10	
906.383*	60 - 500	105	3	10	

Options:

- 836.535 Spare battery type V357
- 495.157 Spare battery type CR2032

* Model with absolute digital display, without thumb wheel, with fine adjustment and preset function.

Digital calipers with inside angled measuring pins

These calipers are equipped with inward angled rounded pins.

- Measuring range: 0 - 500 mm.
- Resolution: 0.01 mm.
- mm/inch conversion.
- On/off switch.
- Reset.
- Large LCD display.
- Thumb wheel/locking screw.

- Power supply: 1 battery type V357 (except 906.371).

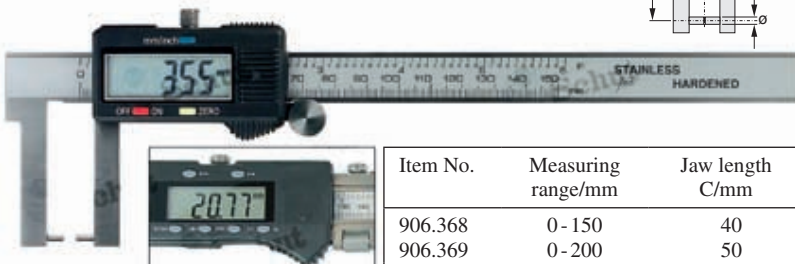
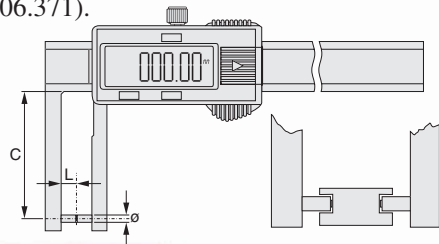

906.368

PRICE

Item No.	Measuring range/mm	Jaw length C/mm	Pin ø/mm	Pin length L/mm	Price HRK
906.368	0 - 150	40	2	5	
906.369	0 - 200	50	2.5	8	
906.370	0 - 300	60	2.5	10	
906.371*	0 - 500	100	3	12	

Options:

- 836.535 Spare battery type V357
- 495.157 Spare battery type CR2032

* Model with absolute digital display, without thumb wheel, with fine adjustment and preset function.

Digital calipers with outside angled measuring jaws

These calipers are equipped with outward angled V-shaped measuring jaws.

- Measuring range: 35 - 500 mm.
- Resolution: 0.01 mm.
- mm/inch conversion.
- On/off switch.
- Reset.
- Large LCD display.
- Thumb wheel/locking screw.
- Power supply:
1 battery type V357
(except 906.363).

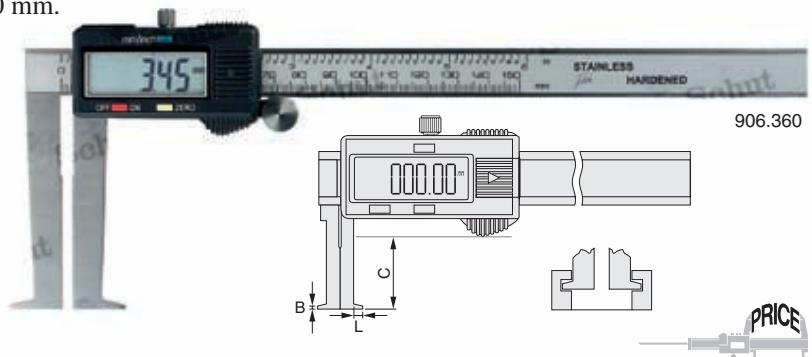

* Model with absolute digital display, without thumb wheel, with fine adjustment and preset function.

Item No.	Measuring range/mm	Jaw length C/mm	Measuring face B/mm	Jaw length L/mm	Price HRK
906.360	35 - 150	50	1.5	6	
906.361	40 - 200	60	1.5	7	
906.362	50 - 300	70	1.5	8	
906.363*	60 - 500	110	2	10	
Options:					
836.535	Spare battery type V357				
495.157	Spare battery type CR2032				

Digital calipers with inside angled measuring jaws

These calipers are equipped with inward angled V-shaped measuring jaws.

- Measuring range: 0 - 500 mm.
- Resolution: 0.01 mm.
- mm/inch conversion.
- On/off switch.
- Reset.
- Large LCD display.
- Thumb wheel/locking screw.
- Power supply:
1 battery type V357
(except 906.358).

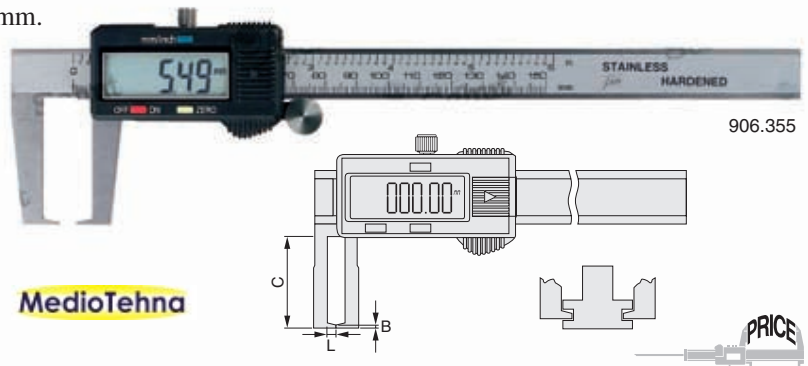

* Model with absolute digital display, without thumb wheel, with fine adjustment and preset function.

Item No.	Measuring range/mm	Jaw length C/mm	Measuring face B/mm	Jaw length L/mm	Price HRK
906.355	0 - 150	40	1	5	
906.356	0 - 200	50	1	7	
906.357	0 - 300	60	1.5	8	
906.358*	0 - 500	100	2	12	
Options:					
836.535	Spare battery type V357				
495.157	Spare battery type CR2032				

Digital calipers for internal length measurement

Calipers with outward angled, pointed measuring jaws for the measurement of for example internal grooves.

- Measuring range: 3 - 200 mm.
- Resolution: 0.01 mm.
- mm/inch conversion.
- On/off switch.
- Reset.
- Large LCD display.
- Locking screw.
- Power supply: 1 battery type V357.

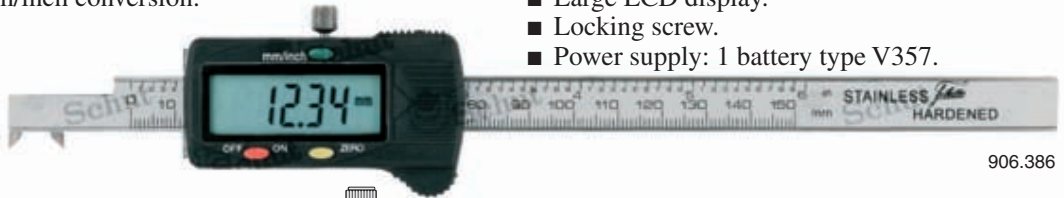

906.386

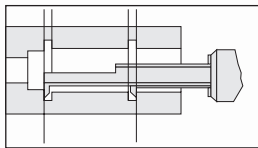
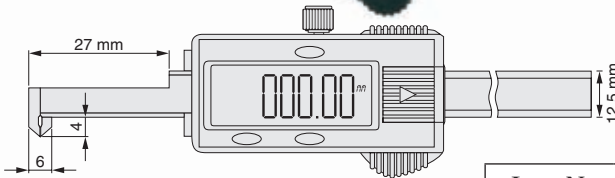

MedioTehna

Item No.	Measuring range/mm	Price HRK
906.386	3 - 125	
906.387	3 - 200	
Option:		
836.535	Spare battery type V357	

Digital caliper for groove measurements

- Measuring range: 0 - 125 mm.
- Resolution: 0.01 mm.
- mm/inch conversion.
- On/off switch.
- Reset.
- Large LCD display.
- Equipped with small measuring jaws on top of the caliper.
- Thumb wheel/locking screw.
- Also suitable for:
 - internal diameter attached collar,
 - internal diameter U-shaped flange on axis,
 - center distances blind holes under-surface flange on axis,
 - hole diameter hard-to-reach places,
 - height measurement,
 - groove width and groove distance.
- Power supply: 1 battery type V357.

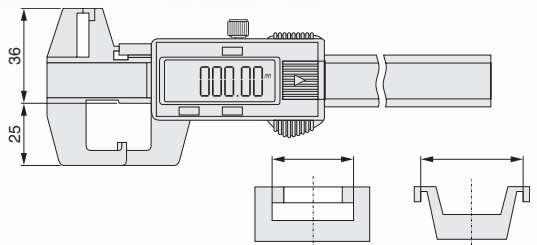
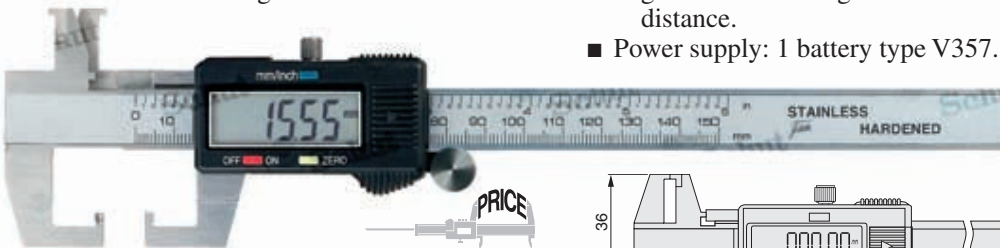

Item No.	Measuring range/mm	Price HRK
906.365	0 - 125	
Option:		
836.535	Spare battery type V357	

Digital calipers with pointed anvil

With the pointed anvil and the long measuring jaws you can measure all sorts of wall thicknesses in places that are hard to reach and of for example round surfaces.

- Measuring range: 0- 150 mm.
- Resolution: 0.01 mm.
- mm/inch conversion.
- On/off switch.
- Reset.
- Large LCD display.
- Power supply: 1 battery type V357.

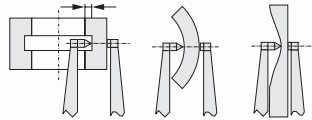
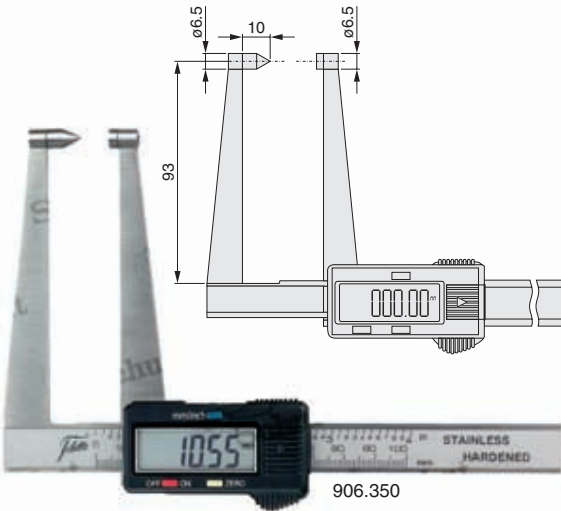

Item No.	Measuring range/mm	Price HRK
906.350	0- 75	
906.351	0- 125	
906.352	0- 150	
Option:		
836.535	Spare battery type V357	

Digital gear tooth thickness calipers

The vertical slider sets the height (H) from the top of the tooth to the pitch line. Subsequently, the horizontal slider measures the tooth thickness (G) at the pitch line.

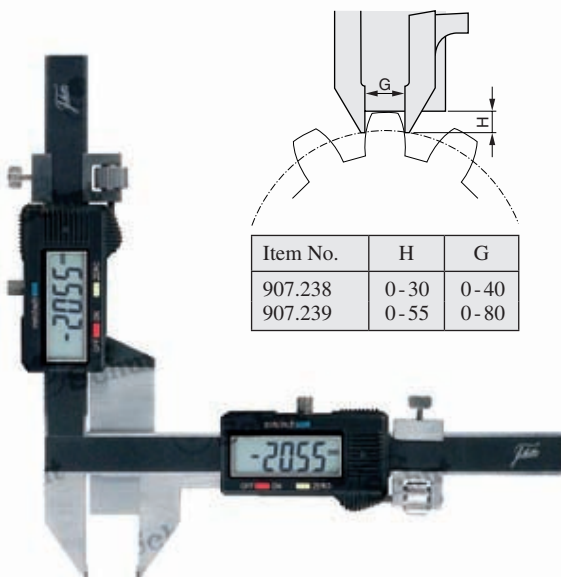

Item No.	H	G
907.238	0-30	0-40
907.239	0-55	0-80

- Measuring range: module 1-50.
- Resolution: 0.01 mm.
- mm/inch conversion.
- On/off switch.
- Reset.
- Large LCD display.
- Fine adjustment.
- Locking screw.
- Tungsten carbide measuring faces.
- Power supply: 2 batteries type V357.



Item No.	Module	Price HRK
907.238	1-30	
907.239	5-50	
Option:		
836.535	Spare battery type V357 (2 needed)	

Digital calipers with long measuring knives

Digital calipers with long measuring knives for internal measurements.

- Measuring range: 0-200 mm.
- Resolution: 0.01 mm.
- mm/inch conversion.
- On/off switch.
- Reset.
- Large LCD display.
- Locking screw/flat depth rod.
- Power supply: 1 battery type V357.



MedioTehna

Item No.	Measuring range/mm	A mm	B mm	C mm	D mm	Price HRK
910.280	0-150	40	45	35	16	
910.281	0-200	50	50	40	16	
Option:						
836.535	Spare battery type V357					

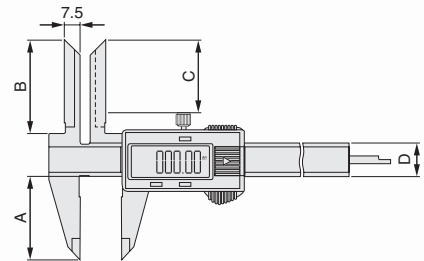

Digital calipers for internal measurements

Calipers with long measuring jaws for internal measurements.

- Measuring range: 15-300 mm.
- Resolution: 0.01 mm.
- mm/inch conversion.
- On/off switch.
- Reset.
- Large LCD display.
- Locking screw.
- Power supply: 1 battery type V357 (except 906.825/827/829).



MedioTehna



Item No.	Measuring range/mm	Effective jaw length mm	Price HRK
906.824	15-150	50	
906.825*	25-150	130	
906.826	18-200	65	
906.827*	25-200	130	
906.828	20-300	80	
906.829*	25-300	130	
Options:			
836.535	Spare battery type V357		
495.157	Spare battery type CR2032		

Digital radius caliper

Digital caliper for direct measurement of a radius for an arc that has an opening angle smaller than 180° (min. 107°).

- Measuring range: 3 - 150 mm.
- Resolution: 0.01 mm.
- mm/inch conversion.
- On/off switch.
- Reset.
- Large LCD display.
- Locking screw.
- Power supply: 1 battery type V357.



Item No.	Measuring range/mm	Price HRK
910.272	3 - 150	
Option: 836.535 Spare battery type V357		

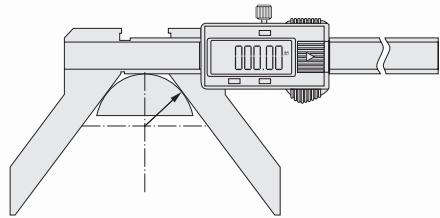

Digital calipers with rotatable LCD display

- Measuring range: 0 - 300 mm.
- Resolution: 0.01 mm.
- mm/inch conversion.
- On/off switch.
- Automatic switch-off.
- Reset.
- Rotatable display.
- Rotatable display value.
- Thumb wheel/locking screw/flat depth rod.
- Delivery in a plastic case with a manufacturer measuring report.
- Power supply: 1 battery type CR2032.

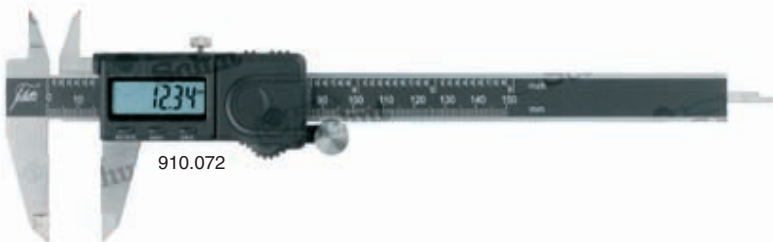

Item No.	Measuring range/mm	Jaw length mm	Price HRK
910.072	0 - 150	40	
910.073	0 - 200	50	
910.074	0 - 300	60	
Option: 495.157 Spare battery type CR2032			

Caliper with prismatic anvil

Caliper with prismatic anvil for measuring objects with an uneven number of grooves like cutters, reamers and drills. The angle of the prism aperture is designed for workpieces having a number of 3 flutes.

- Measuring range: 4-40 mm.
- Locking screw.
- Graduation: 0.05 mm.
- Accuracy: ± 0.05 mm.



NEW

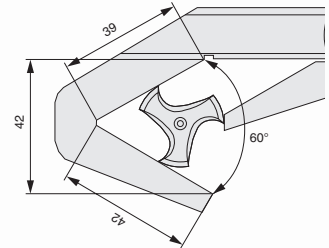

Item No.	For work-pieces with	Measuring range/mm	Price HRK
Analog 910.431	3 flutes	4-40	

Brake disc calipers

Brake disc calipers especially designed for measuring the groove depth of brake discs.

- Measuring range: 0-90 mm.
- Vernier: 0.1 mm.
- Locking screw.
- Stainless steel construction.

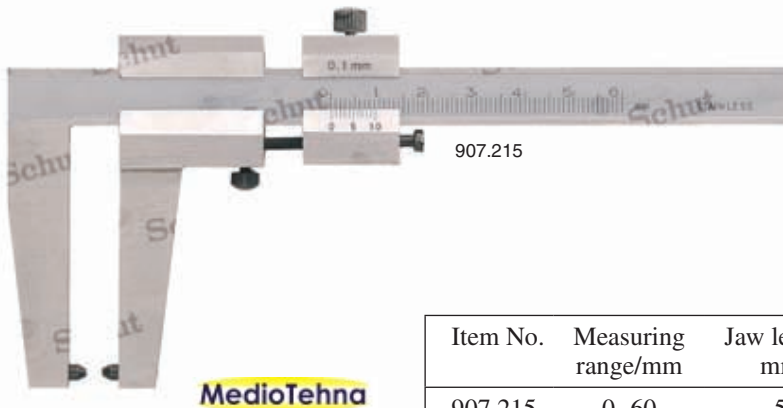

Item No.	Measuring range/mm	Jaw length mm	Price HRK
907.215	0-60	55	
907.216	0-60	80	
907.217	0-90	120	

Absolute digital workshop calipers

Large and solid, stainless steel digital calipers with no-glare chrome finished beam.

- Measuring range: 0-2000 mm.
- Resolution: 0.01 mm.
- mm/inch conversion.
- ABS/INC switchable (except 906.460/686/708).
- On/off switch.
- Reset.
- Preset (except 906.460/686/708).

MedioTehna

- Memory for measuring values when the display is switched off.
- Rounded jaw ends for internal measurements.
- Fine adjustment and locking screw.
- Delivery in a plastic case or a wooden case.
- Power supply: 1 battery type CR2032 (except 906.460/686/708).

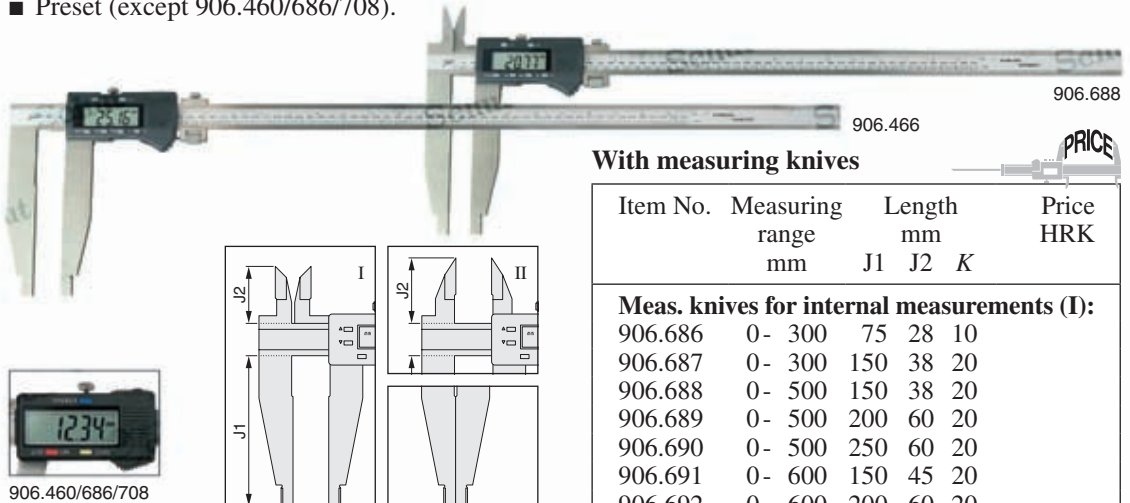

Without measuring knives

Item No.	Measuring range mm	Length mm		Price HRK
		J1	K	
906.708	0- 300	75	10	
906.709	0- 300	150	20	
906.465	0- 500	150	20	
906.470	0- 500	200	20	
906.718	0- 500	250	20	
906.466	0- 600	150	20	
906.471	0- 600	200	20	
906.719	0- 600	300	20	
906.467	0-1000	200	20	
906.472	0-1000	300	20	
906.468 ^{1,2}	0-1500	200	20	
906.473 ^{1,2}	0-1500	300	20	
906.469 ^{1,2}	0-2000	200	20	
906.474 ^{1,2}	0-2000	300	20	

Item No.	Description	Price HRK
495.157	Spare battery type CR2032	
836.535	Spare battery type V357	

With measuring knives

Item No.	Measuring range mm	Length mm			Price HRK
		J1	J2	K	
Meas. knives for internal measurements (I):					
906.686	0- 300	75	28	10	
906.687	0- 300	150	38	20	
906.688	0- 500	150	38	20	
906.689	0- 500	200	60	20	
906.690	0- 500	250	60	20	
906.691	0- 600	150	45	20	
906.692	0- 600	200	60	20	
906.693	0- 600	300	60	20	
906.694	0-1000	200	60	20	
906.695	0-1000	300	60	20	
906.696 ^{1,2}	0-1500	200	60	20	
906.697 ^{1,2}	0-1500	300	60	20	
906.698 ^{1,2}	0-2000	200	60	20	
906.699 ^{1,2}	0-2000	300	60	20	

Meas. knives for external measurements (II):					
906.460	0- 300	75	38	10	
906.758	0- 300	150	56	20	
906.461	0- 500	150	56	20	
906.759	0- 500	200	67	20	
906.760	0- 500	250	80	20	
906.761	0- 600	150	56	20	
906.762	0- 600	200	67	20	
906.763	0- 600	300	80	20	
906.462	0-1000	200	67	20	
906.764	0-1000	300	80	20	
906.463 ^{1,2}	0-1500	200	80	20	
906.765 ^{1,2}	0-1500	300	80	20	
906.464 ^{1,2}	0-2000	200	80	20	
906.766 ^{1,2}	0-2000	300	80	20	

¹ Without graduation on the caliper beam.

² Delivery ex Groningen, Netherlands.

Digital lightweight workshop caliper

Lightweight digital aluminum workshop caliper with both measuring jaws being moveable. Hardened stainless steel measuring jaws, with rounded jaw ends for internal and external measurements. Excellent sliding properties due to double prismatic joint.

- Measuring range: 0-300 mm.
- Resolution: 0.01 mm.
- mm/inch conversion.
- On/off switch.
- Reset.
- Jaw length standard delivered jaw: 90 mm.
- Length meas. knives for external measurements: 40 mm.
- Locking screws.
- Delivery in a plastic case with a manufacturer measuring report.
- Power supply: 1 battery type V357.



Item No.	Measuring range/mm	Accuracy mm	Weight kg	Price HRK
853.200	0-300	0.04	0.5	
Options:				
836.535	Spare battery type V357			
853.219 ¹	Pair measuring jaws 90 mm			
853.220	Pair measuring jaws 125 mm			
853.221	Pair measuring jaws 150 mm			

¹ Standard included.

Digital lightweight workshop caliper

Lightweight digital aluminum workshop caliper with both measuring jaws being moveable. Hardened stainless steel measuring jaws, with rounded jaw ends for internal and external measurements. Excellent sliding properties due to double prismatic joint.

- Measuring range: 0-1500 mm.
- Resolution: 0.01 mm.
- On/off switch.
- Reset.
- Fine adjustment by means of carriage for constant measuring force of 3 N.
- Locking screws.
- Delivery in a plastic case with a manufacturer measuring report.
- Power supply: 1 battery type CR2032.

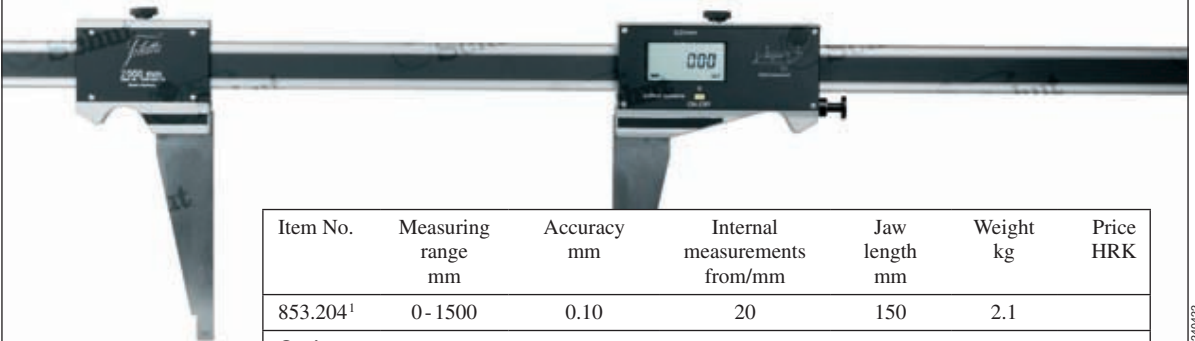

Item No.	Measuring range mm	Accuracy mm	Internal measurements from/mm	Jaw length mm	Weight kg	Price HRK
853.204 ¹	0-1500	0.10	20	150	2.1	
Option:						
495.157	Spare battery type CR2032					

¹ Delivery ex Groningen, Netherlands.

MedioTehna

Digital aluminum workshop calipers

Lightweight digital aluminum workshop calipers with both measuring jaws being moveable.

- Measuring range: 0- 1500 mm.
- Resolution: 0.1 mm.
- mm/inch conversion.
- On/off switch.
- Reset.
- Aluminum scale with hollow construction (8 x 30 mm).
- Both of the measuring jaws can be moved.
- Power supply: 1 battery type V357.

MedioTehna

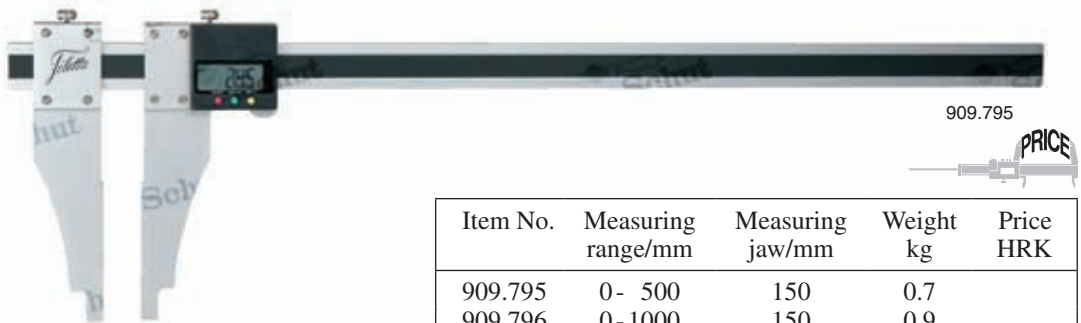

909.795

Item No.	Measuring range/mm	Measuring jaw/mm	Weight kg	Price HRK
909.795	0- 500	150	0.7	
909.796	0- 1000	150	0.9	
909.797 ¹	0- 1500	150	1.1	
Option:				
836.535	Spare battery type V357			

¹ Delivery ex Groningen, Netherlands.

Digital lightweight carbon workshop calipers

Different models are available in many lengths. Calipers can be supplied with for instance extra long measuring jaws, TiN coated or hardened measuring jaws or both measuring jaws being moveable. There are also models where special inserts or slide on probes can be used for measuring for instance center distances, grooves or diameters.

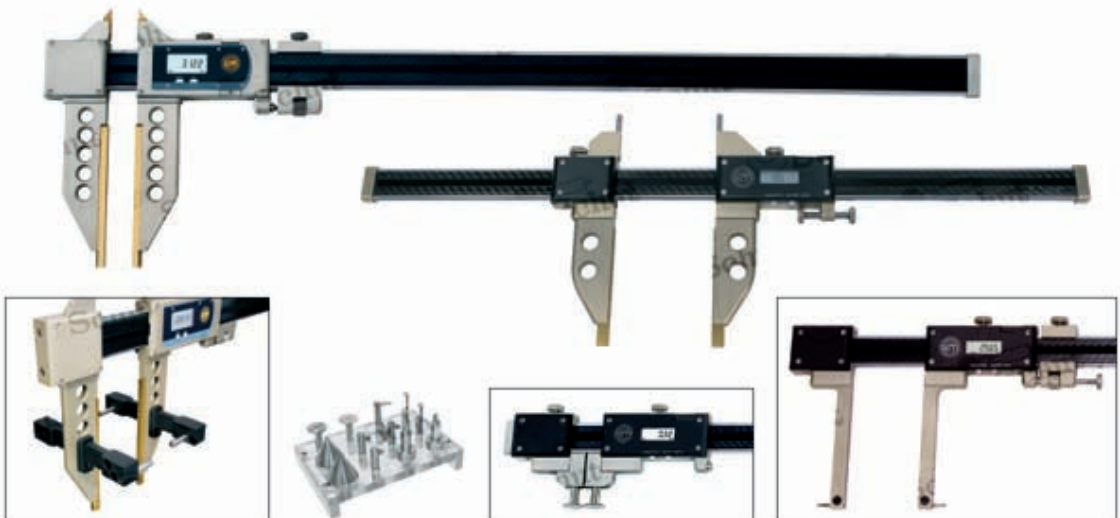

Digital carbon workshop calipers IP65

Workshop calipers with large measuring jaws, Bluetooth, and an ultra lightweight carbon fiber construction that saves up to 65% of the total weight compared to a steel workshop caliper.

- Measuring range: 0-2000 mm.
- Resolution: 0.01 mm.
- mm/inch conversion.
- ABS/INC switchable.
- Digimatic data output.
- Bluetooth data output.
- On/off switch.
- Reset/preset.
- Hold function.



- Fine adjustment by means of carriage for constant measuring force between 5-10 N.
- Carbon jaws with steel measuring faces.
- Rounded jaw ends for internal measurements.
- Locking screw.
- Protection: IP65.
- Delivery in a wooden case with a manufacturer measuring report.
- Power supply: 1 battery type CR2032.

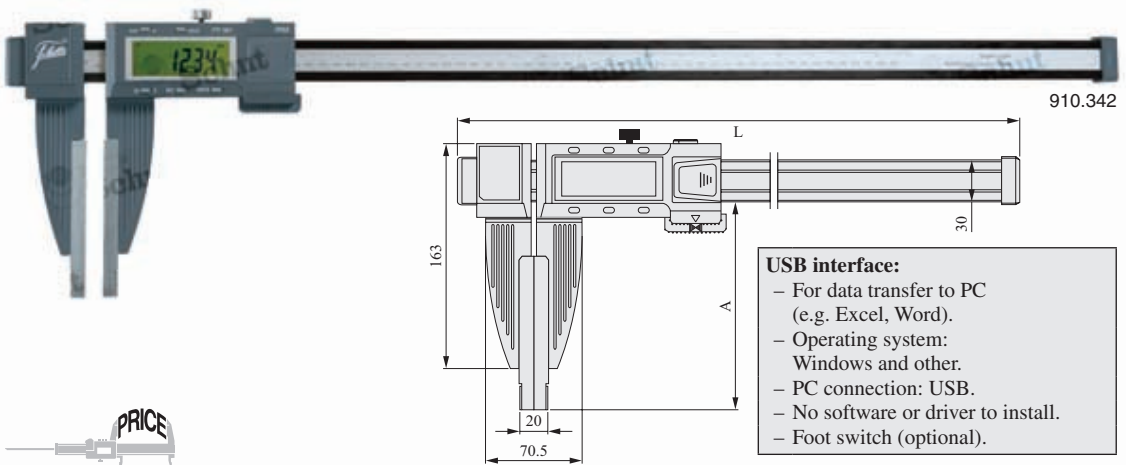

USB interface:

- For data transfer to PC (e.g. Excel, Word).
- Operating system: Windows and other.
- PC connection: USB.
- No software or driver to install.
- Foot switch (optional).

Item No.	Measuring range/mm	Accuracy mm	Jaw length A/mm	Weight kg	Length L/mm	Price HRK
910.342	0- 600	±0.06	130	1.3	826	
910.343	0- 600	±0.08	200	1.4	826	
910.344	0- 600	±0.12 ²	300	1.5	826	
910.345	0-1000	±0.08	130	1.5	1226	
910.346	0-1000	±0.12	200	1.6	1226	
910.347	0-1000	±0.16 ²	300	1.7	1226	
910.349 ¹	0-1500	±0.16	150	2.0	1736	
910.350 ¹	0-1500	±0.21 ²	300	2.1	1736	
910.352 ¹	0-2000	±0.21	200	2.6	2246	
910.353 ¹	0-2000	±0.25 ²	300	2.7	2246	

Options:

- 495.157 Spare battery type CR2032
- 909.686³ USB interface
- 909.687 Footswitch for USB interface
- 910.038 Wireless USB receiver
- 910.039³ Wireless transmitter

¹ Delivery ex Groningen, Netherlands.

² Depending on the measuring force, only valid in the upper part of the measuring jaws.

³ For instruments with a Digimatic data output.

Universal digital calipers

Large universal digital calipers for internal and external measurements.

In combination with these universal calipers many inserts are available e.g. for internal/external measurements or measuring center distances between bores up to \varnothing 14.5 mm.

- Internal measuring range¹: 20-300 mm.
- External measuring range¹: 0-300 mm.
- Resolution: 0.01 mm.
- mm/inch conversion.
- On/off switch.
- Reset.
- Large LCD display.
- Locking screw.
- Power supply: 1 battery type V357.
- Delivery without inserts.

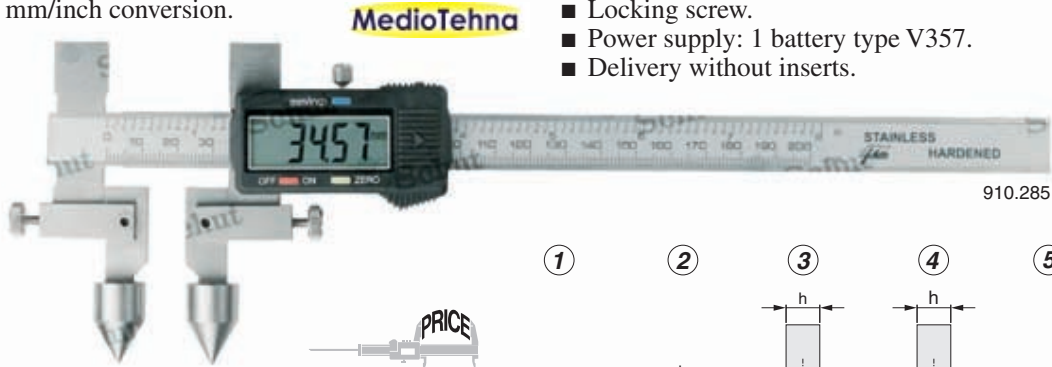

Item No.	Measuring range/mm internal ¹ external ¹	Price HRK
910.285	20-200 0-200	
910.286	20-300 0-300	
Option: 836.535 Spare battery type V357		

¹The measuring range can change depending on inserts.

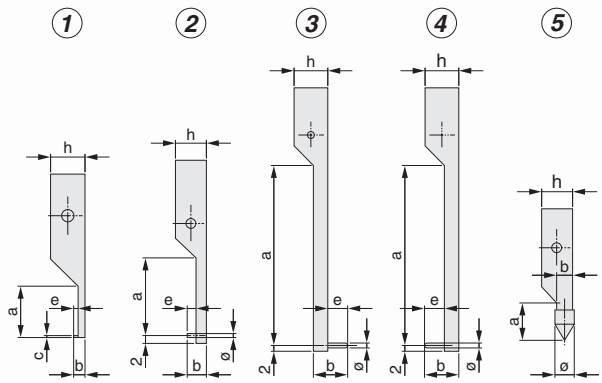

Inserts

No.	Item No.	Description	Length/mm					ø mm	Price HRK
			a	b	c	e	h		
①	910.287	For internal/external measurements	12	2.5	0.4	1	8		
①	910.288	For internal/external measurements	16	3.5	0.4	2	8		
①	910.289	For internal/external measurements	25	7.5	0.6	5	8		
①	910.290	For internal/external measurements	30	10	1	6.5	8		
①	910.292	For internal/external measurements	80	22	1	10	12		
②	910.293	For internal/external measurements	20	5		2	8	1	
②	910.294	For internal/external measurements	40	10		5	8	2	
②	910.295	For internal/external measurements	80	22		10	12	2	
③	910.296	For external measurements	70	12		7	12	2	
③	910.297	For external measurements	70	12		7	12	4	
④	910.298	For internal measurements	70	12		7	12	2	
④	910.299	For internal measurements	70	12		7	12	4	
⑤	910.300	For center distances	10	4	—		8	5	
⑤	910.301	For center distances	20	4	—		8	10	
⑤	910.302	For center distances	25	8	—		12	15	

Universal digital calipers

Universal digital calipers with exchangeable measuring inserts for special purposes. Thanks to the seven interchangeable measuring inserts, which are available as an option, you are very flexible with these universal calipers.

- Internal measuring range¹: 40-500 mm.
- External measuring range¹: 0-500 mm.
- Resolution: 0.01 mm.
- mm/inch conversion.
- On/off switch.
- Reset.
- Large LCD display.

- Locking screw.
- Power supply: 1 battery type V357.
- Standard supplied with measuring insert 1.

Only 910.306:

- Absolute digital display.
- Reset/preset.
- Power supply: 1 battery type CR2032.

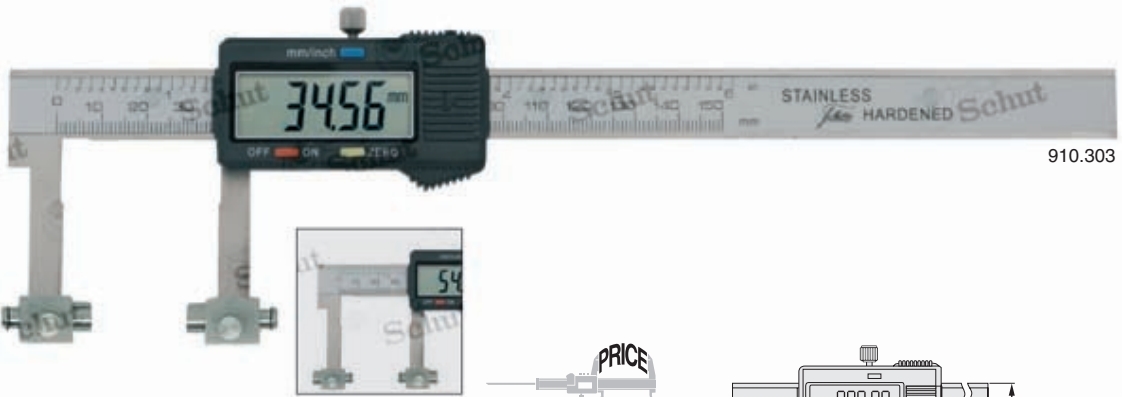

910.303

Item No.	Measuring range/mm internal ¹ external ¹	a/mm	b/mm	Price HRK
910.303	40-150 0-150	45	7	
910.304	40-200 0-200	85	10	
910.305	40-300 0-300	100	15	
910.306*	40-500 0-500	140	20	

Options:

- 836.535 Spare battery type V357
- 495.157 Spare battery type CR2032

¹ The measuring range can change depending on inserts. The measuring range indicated is with standard inserts.

No.	Item No.	Description measuring faces	Price HRK
Measuring inserts, per pair:			
①	906.788	flat	
②	906.789	spherical	
③	906.790	small	
④	906.791	disc	
⑤	906.792	knife/flat	
⑥	906.793	point	
⑦	906.794	knife	
	906.795	Set of 7 pairs	

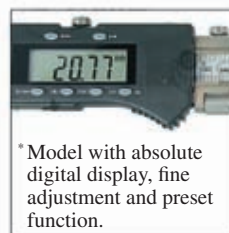
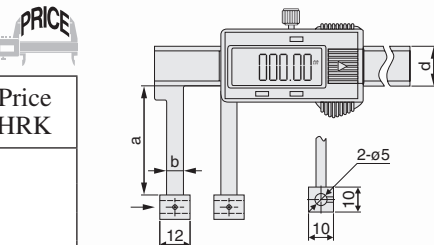

* Model with absolute digital display, fine adjustment and preset function.

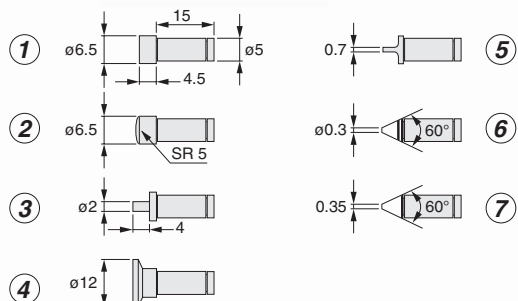

Universal digital calipers

Universal digital calipers with interchangeable measuring inserts for varying purposes. By using M2.5 thread, many different measuring inserts can be used in combination with these calipers. Please see the dial indicator accessories for these inserts.

- Internal measuring range¹: 20-500 mm.
- External measuring range¹: 0-500 mm.
- Resolution: 0.01 mm.
- mm/inch conversion.
- On/off switch.
- Reset.
- Large LCD display.

- Locking screw.
- Power supply: 1 battery type V357.
- Standard supplied without inserts.

Only 910.333:

- Absolute digital display.
- Reset/preset.
- Power supply: 1 battery type CR2032.

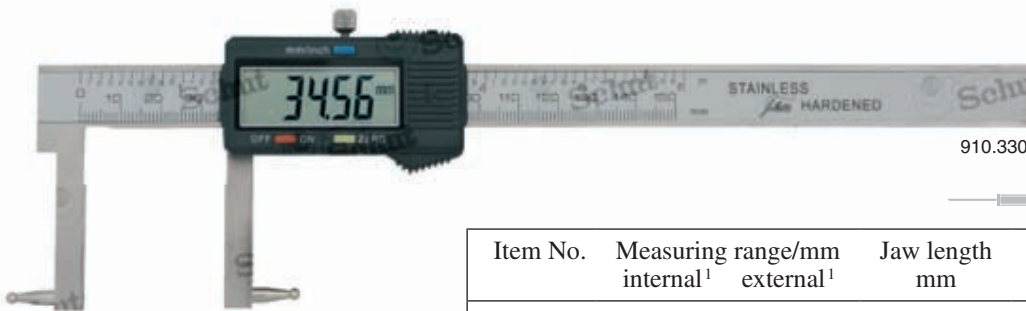

910.330



Item No.	Measuring range/mm		Jaw length mm	Price HRK
	internal ¹	external ¹		
910.330	20-150	0-150	45	
910.331	25-200	0-200	85	
910.332	30-300	0-300	90	
910.333*	35-500	0-500	150	

Options:
 836.535 Spare battery type V357
 495.157 Spare battery type CR2032

¹ The measuring range can change depending on inserts.

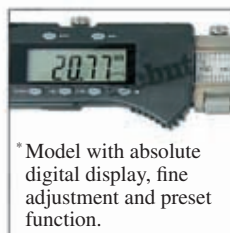

* Model with absolute digital display, fine adjustment and preset function.



Inserts examples. For more information see the dial indicator accessories section.

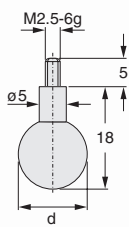

852.426-430

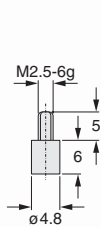

852.431/432

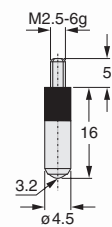

852.406-409

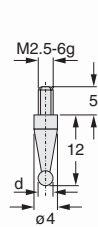

852.414-425

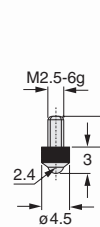

852.401

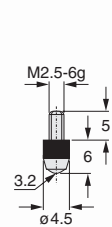

852.402-405

Digital lightweight universal workshop caliper

Universal lightweight aluminum workshop caliper with interchangeable measuring inserts for special purposes with both measuring jaws being moveable. All inserts with M2.5 thread can be used with this caliper. Please see the dial indicator accessories section for these inserts.

- Internal measuring range¹: 30-300 mm.
- External measuring range¹: 0-300 mm.
- Resolution: 0.01 mm.
- mm/inch conversion.
- Tolerance function.
- On/off switch.
- Reset/preset.
- Interchangeable measuring inserts: 1 pair included (ball attachment $\varnothing 3.2$ mm, $l=6$ mm).
- Fine adjustment.
- Locking screws.
- Delivery in a plastic case.
- Power supply: 1 battery type CR2032.

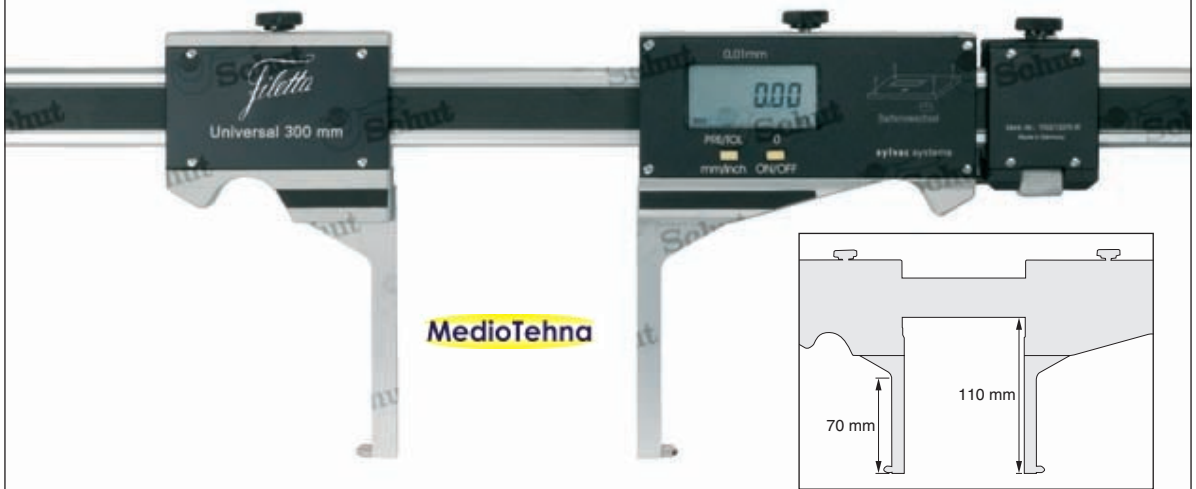

Item No.	Measuring range/mm internal ¹ external ¹	Accuracy mm	Weight kg	Price HRK
853.206	30- 300 0- 300	0.04	1	
Option: 495.157 Spare battery type CR2032				

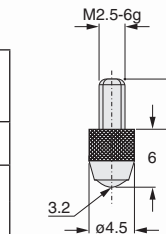

¹ The measuring range can change depending on inserts.

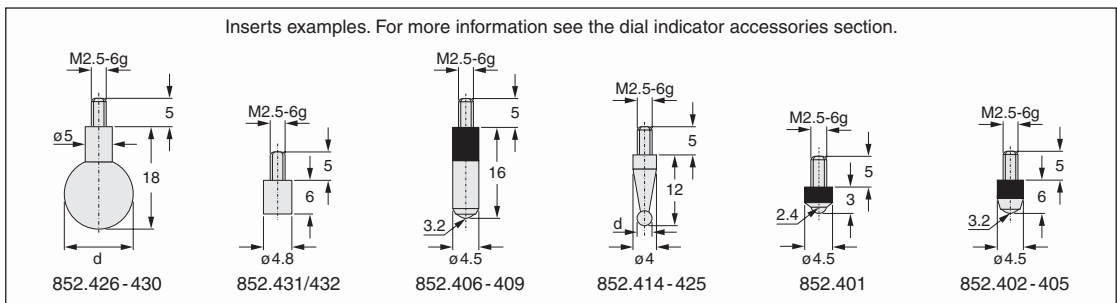

Universal digital calipers IP67

Large universal digital calipers made of stainless steel for internal and external measurements. In combination with these universal calipers many inserts are available e.g. for measuring thread. See accessories universal digital calipers.

- Internal measuring range: 24 - 650 mm.
- External measuring range: 0 - 570 mm.
- Resolution: 0.01 mm.
- Accuracy: ± 0.02 or ± 0.03 mm.
- mm/inch conversion.
- Proximity data output.
- On/off switch.
- Reset/preset.
- Interchangeable measuring inserts.
- Many extensions and inserts available.
- Protection: IP67.
- Conforms to factory standard.
- Delivery in a wooden case with a manufacturer measuring report, two inserts and two insert holders.
- Power supply: 1 battery type CR2032.

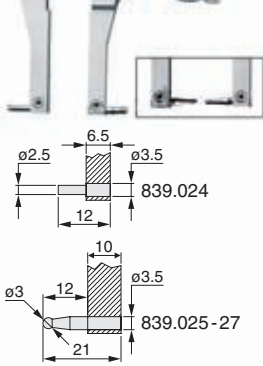

Item No.	Measuring range/mm internal external	Accuracy mm	Jaw length mm	Price HRK
839.024	24-250 0-210	± 0.02	64	
839.025 ¹	42-350 0-270	± 0.03	103	
839.026 ¹	42-450 0-370	± 0.03	103	
839.027 ¹	42-650 0-570	± 0.03	103	
Options:				
495.157	Spare battery type CR2032			
840.666	Proximity USB cable (2 m)			

¹ Inserts 837.821 and insert holders standard included.

Universal digital calipers accessories

Inserts for thread measurements, per pair

Pitch mm	Item No.	Price HRK	Item No.	Price HRK
	Internal meas.:		External meas.:	
0.4 - 0.5	839.010		839.018	
0.6 - 0.9	839.011		839.019	
1 - 1.75	839.014		839.020	
2 - 3	839.015		839.021	
3.5 - 5	839.016		839.022	
5.5 - 7	839.017		839.023	



Steel inserts (M2.5), per pair

Item No.	Diameter A/mm	Length B/mm	Price HRK
837.818	1.5	12	
837.819	2	12	
837.820	2.5	12	
837.821	3	12	
837.822	3.5	12	
837.823	4	12	
837.824	4.5	12	
837.825	5	12	
837.826	5.5	12	
837.827	6	12	
837.828	6.5	12	
837.829	7	18	
837.830	8	18	
837.831	10	18	

Insert holders (M2.5), per piece

Item No.	Length C/mm	Price HRK
837.832	8	
837.833	10	
839.054	12	
839.055	20	
839.056	50	

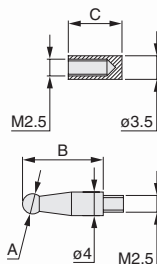

Dial calipers

Stainless steel dial calipers with protected rack.

- Measuring range: 0-300 mm.
- Graduation: 0.01 or 0.02 mm.
- Accuracy: ± 0.03 mm.
- 1 pointer revolution = 1 or 2 mm.
- Rotatable dial.
- Thumb wheel.
- Delivery in a plastic case.

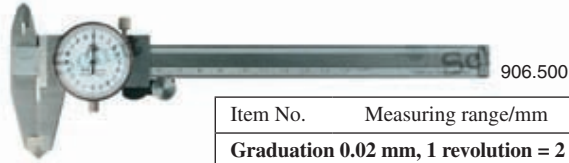

Item No.	Measuring range/mm	Price HRK
Graduation 0.02 mm, 1 revolution = 2 mm:		
906.500	0 - 150	
906.499	0 - 200	
906.501	0 - 300	
Graduation 0.01 mm, 1 revolution = 1 mm:		
906.498	0 - 150	



High-quality plastic calipers

These modern designed Swiss calipers are made of fiberglass reinforced plastic, which makes them very firm and light, wear-proof, and resistant to all kinds of chemicals – ideal for the workshop!

- Measuring range: 0-150 mm.
- Thumb wheel.
- Flat depth rod.

Vernier caliper

- Vernier: 0.1 mm / 1/64 inch.
- The scale lights up with minimal light.

Dial caliper

- Graduation: 0.1 mm.
- 1 pointer revolution = 10 mm.
- Rotatable dial, $\varnothing 32$ mm.
- The dial is shockproof and can be set to zero.

Digital caliper

- Resolution: 0.01 mm.
- mm/inch conversion.
- On/reset switch.
- Off switch.
- Power supply: 1 battery type V357.

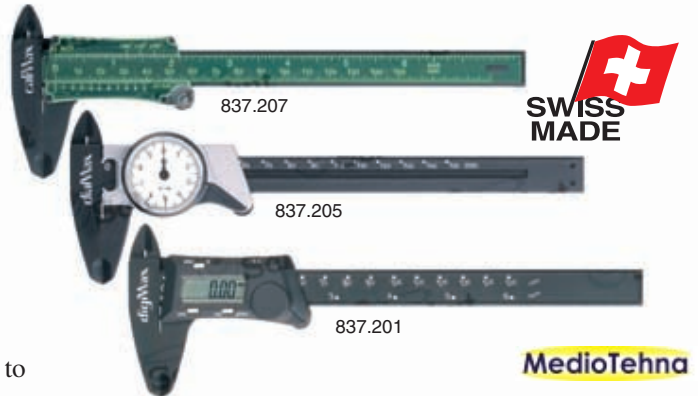

Item No.	Description	Price HRK
837.207	Vernier caliper	
837.205	Dial caliper	
837.201	Digital caliper	
Option:		
836.535	Spare battery type V357	

Brass caliper

Brass caliper with a vernier.

- Measuring range: 0-100 mm.
- Vernier: 0.1 mm, parallax-free.
- Dovetail guide.
- Antimagnetic.



841.628



Item No.	Measuring range/mm	Jaw length mm	Price HRK
841.628	0 - 80	20	
841.629	0 - 100	20	

Calipers

Hardened stainless steel calipers with a matt chrome-plated beam and vernier.

- Measuring range: 0-300 mm.
- Vernier: 0.05 or 0.02 mm.
- Raised sliders (except 909.538).
- Accuracy: ± 0.03 mm.
- Monoblock.
- Locking screw or spring release.
- Flat depth rod (except 909.423/424).
- Thread table on the back side.
- Delivery in a sleeve.

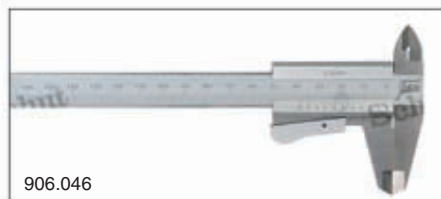
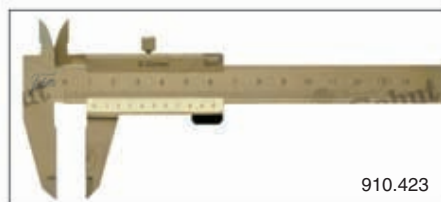
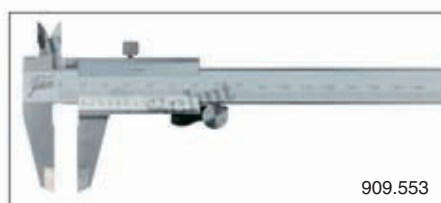
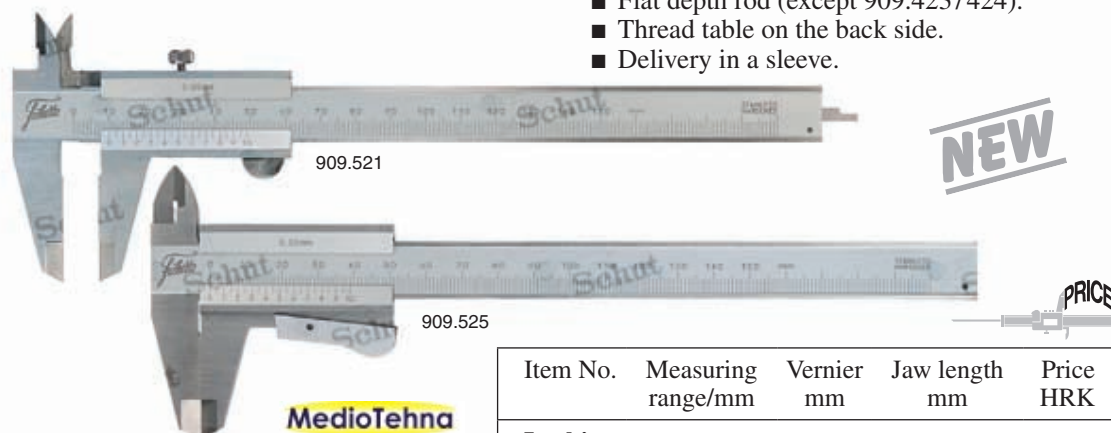

Item No.	Measuring range/mm	Vernier mm	Jaw length mm	Price HRK
Locking screw on top:				
909.541	0-150	0.02	40	
909.542	0-160	0.02	40	
909.543	0-200	0.02	50	
909.544	0-300	0.02	62	
Locking screw on top:				
909.520	0-100	0.05	30	
909.521	0-150	0.05	40	
909.522	0-160	0.05	40	
909.523	0-200	0.05	50	
909.524	0-300	0.05	62	
With thumb wheel (locking screw on top):				
909.553	0-150	0.05	40	
909.554	0-200	0.05	50	
909.555	0-300	0.05	62	
Spring release:				
909.525	0-150	0.05	40	
909.526	0-160	0.05	40	
909.527	0-200	0.05	50	
909.528	0-300	0.05	62	
Brass calipers (without depth rod):				
910.424	0-150	0.05	40	
910.423	0-150	0.02	40	
Parallax-free (spring release):				
909.538	0-150	0.05	40	
Spring release, left-handed model:				
906.046	0-150	0.05	40	
906.047	0-150	0.02	40	

Parallax-free lightweight workshop calipers

Lightweight parallax-free aluminum workshop calipers with interchangeable hardened stainless steel measuring jaws, with rounded jaw ends for internal and external measurements. High contrast reading due to white print on black background. Excellent sliding properties due to double prismatic joint.

- Measuring range: 0-900 mm.
- Vernier: 0.05 mm / 1/128 inch.
- Jaw length standard delivered jaw: 90 mm.
- Length meas. knives for external measurements: 40 mm.
- Parallax-free.
- Locking screw.
- Delivery in a plastic case.

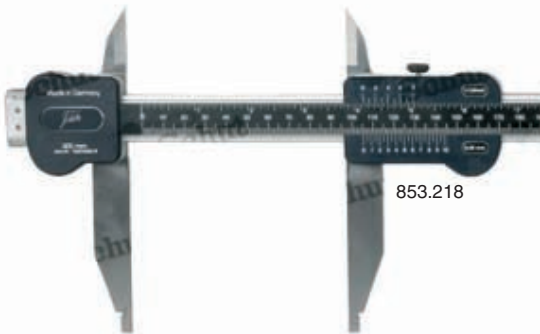

Item No.	Measuring range/mm	Weight kg	Price HRK
853.217	0-500	0.6	
853.218	0-900	0.8	
Options:			
853.219 ¹	Pair measuring jaws 90 mm		
853.220	Pair measuring jaws 125 mm		
853.221	Pair measuring jaws 150 mm		

¹ Standard included.

Workshop calipers

Hardened stainless steel workshop calipers with a matt chrome-plated beam and vernier.

- Measuring range: 0-1500 mm.
- Vernier: 0.02 mm.
- Raised sliders.
- Fine adjustment.
- With measuring knives or rounded jaw ends for internal measurements.
- Locking screws.
- Delivery in a plastic case.



906.230



Item No.	Measuring range mm	Internal measurements from/mm	Jaw length mm	Price HRK
With measuring knives for internal measurements:				
906.230	0- 300	–	65	
With rounded jaw ends for internal measurements:				
906.231	0- 300	10	90	
906.233	0- 500	10	100	
906.234	0- 600	10	100	
906.235	0- 1000	20	125	
906.236 ¹	0- 1500	20	125	

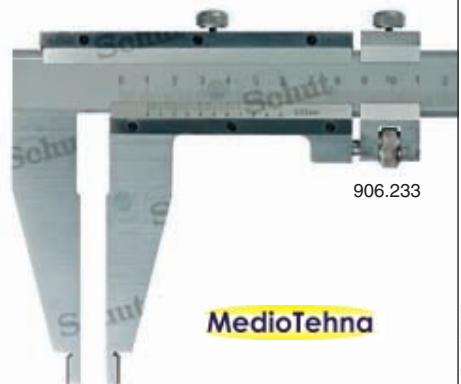

906.233

MedioTehna

¹ Delivery ex Groningen, Netherlands.

Workshop calipers

Large and solid, stainless steel calipers with a matt chrome-plated beam and vernier.

- Measuring range: 0-2000 mm.
- Vernier: 0.02 mm / 1/1000 inch or 0.05 mm / 1/128 inch.
- Fine adjustment.
- With or without measuring knives for internal or external measurements.
- Monoblock.
- Rounded jaw ends for internal measurements; measuring range ≤ 600 mm: $K=10$ mm, measuring range > 600 mm: $K=20$ mm.
- Locking screws.
- Delivery in a wooden case.

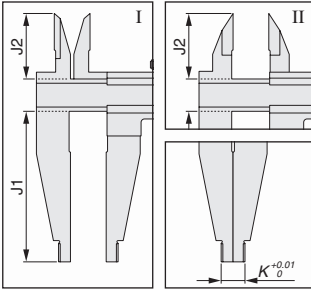

Vernier 0.05 mm / 1/128 inch

Vernier 0.02 mm / 1/1000 inch

Item No.	Measuring range mm	Length mm			Price HRK
		J1	J2	K	
Without measuring knives:					
909.670	0- 300	90	-	10	
909.620	0- 450	150	-	10	
909.621	0- 500	150	-	10	
909.622	0- 600	150	-	10	
909.623	0- 800	150	-	20	
909.624	0-1000	150	-	20	
909.639 ¹	0-1500	200	-	20	
909.640 ¹	0-2000	200	-	20	
Meas. knives for internal measurements (I):					
909.672	0- 300	90	22	10	
909.632	0- 400	100	46	10	
909.633	0- 500	150	46	10	
909.634	0- 600	150	46	10	
909.635	0- 750	150	54	20	
909.636	0-1000	150	54	20	
909.637 ¹	0-1500	200	66	20	
909.638 ¹	0-2000	200	66	20	
Meas. knives for external measurements (II):					
909.674	0- 300	90	22	10	
909.656	0- 400	100	46	10	
909.657	0- 500	150	46	10	
909.658	0- 600	150	46	10	
909.659	0- 750	150	54	20	
909.660	0-1000	150	54	20	
909.661 ¹	0-1500	200	66	20	
909.662 ¹	0-2000	200	66	20	

Item No.	Measuring range mm	Length mm			Price HRK
		J1	J2	K	
Without measuring knives:					
909.671	0- 300	90	-	10	
909.615	0- 450	150	-	10	
909.616	0- 500	150	-	10	
909.617	0- 600	150	-	10	
909.618	0- 800	150	-	20	
909.619	0-1000	150	-	20	
909.641 ¹	0-1500	200	-	20	
909.642 ¹	0-2000	200	-	20	
Meas. knives for internal measurements (I):					
909.673	0- 300	90	22	10	
909.625	0- 400	100	46	10	
909.626	0- 500	150	46	10	
909.627	0- 600	150	46	10	
909.628	0- 750	150	55	20	
909.629	0-1000	150	55	20	
909.630 ¹	0-1500	200	66	20	
909.631 ¹	0-2000	200	66	20	
Meas. knives for external measurements (II):					
909.675	0- 300	90	22	10	
909.663	0- 400	100	46	10	
909.664	0- 500	150	46	10	
909.665	0- 600	150	46	10	
909.666	0- 750	150	55	20	
909.667	0-1000	150	55	20	
909.668 ¹	0-1500	200	66	20	
909.669 ¹	0-2000	200	66	20	

¹ Delivery ex Groningen, Netherlands.

¹ Delivery ex Groningen, Netherlands.

Probe set for calipers

This probe set enlarges the possibilities with a regular caliper. Probe holders are slid on the measuring jaw of the caliper. The different probes can be screwed into them. The probe set makes it possible to perform measurements which are not possible with a regular caliper, such as measuring internal grooves and center distances.

- Screw thread probe holder: M3.
- Maximum caliper jaw thickness: 3.5 mm (mostly compatible with calipers with a measuring range ≤ 150 mm).
- Delivery in a wooden case.



MedioTehna

The set consists of:

- ① right probe holder,
- ② left probe holder,
- ③ pair of disc probes $\varnothing 6$ mm,
- ④ pair of disc probes $\varnothing 10$ mm,
- ⑤ pair of disc probes $\varnothing 12.5$ mm,
- ⑥ pair of cone probes $\varnothing 9$ mm, 60° ,
- ⑦ pair of cone probes $\varnothing 12.5$ mm, 60° ,
- ⑧ pair of cylindrical probes $\varnothing 1.5 \times 9$ mm,
- ⑨ hexagon key.

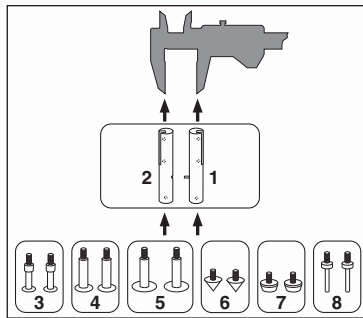

\varnothing		
6 mm	>16 mm	>4 mm
10 mm	>20 mm	>1 mm
12.5 mm	>22 mm	>0 mm

3, 4, 5
Disc probes for internal measurements.

6
Conical probes (9 mm) for measuring center distances of two equal holes.

7
Conical probes (12.5 mm) for measuring center distances of two equal holes.

8
Horizontally positioned cylindrical probes for measuring internal grooves > 45 mm.

8
Vertically positioned cylindrical probes.

Item No.	Description	Price HRK
909.655	Probe set for calipers	

Caliper inspection set

For checking the accuracy of DIN 862 calipers. The set consists of three special steel gauge blocks (30 mm, 41.3 mm and 131.4 mm, ISO 3650 class 1), two steel setting rings (ø4 mm and ø25 mm) and a pair of gloves.

- Delivery in a wooden case with a manufacturer measuring report.



Item No.	Description	Price HRK
909.347	Caliper inspection set	

Depth measuring base for calipers

Universal depth measuring base for stable and accurate depth measurements. Suitable for most of the calipers with a depth rod and a measuring range up to 200 mm. For more information please contact our sales department.

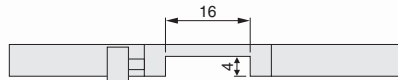

Item No.	Measuring face l x w/mm	Price HRK
909.156	75 x 6	

Depth measuring bases for calipers

Universal depth measuring bases for stable and accurate depth measurements. Suitable for most of the calipers with a depth rod and a measuring range up to 200 mm. For more information please contact our sales department.



909.386

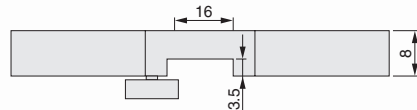

Item No.	Measuring face l x w/mm	Price HRK
909.386	80 x 8	
909.387	100 x 8	

MedioTehna

Wooden cases for calipers

Wooden cases of high quality with foam inlay for calipers.



836.416

Item No.	Inside dimensions <i>l x w x h</i> /mm	Price HRK
836.455	250 x 90 x 20	
836.437	315 x 145 x 20	
836.416	435 x 175 x 20	
836.406	610 x 180 x 20	
836.400	690 x 200 x 20	
836.349	690 x 250 x 25	
836.387	790 x 200 x 25	
836.399	1000 x 270 x 25	
841.305	1100 x 480 x 25	

MedioTehna

Caliper holder

Plastic holder for calipers (analog and digital; regular shaped) of 150 mm.

- For regular shaped calipers (analog and digital).
- Delivery including mounting set (belt clip and mounting clip).
- Rotatable 360°.



Item No.	For meas. range/mm	Price
360.000	150	

Cases for calipers

- For regular shaped vernier calipers.
- For regular shaped calipers (analog, digital and dial type) (only 910.108 - 910.110).



909.495



910.108

Item No.	For meas. range/mm	Price
Plastic cases:		
910.108	150	
910.109	200	
910.110	300	
Soft cases made of synthetic leather:		
909.494	100	
909.495	150	
909.496	160	
909.497	200	
909.498	300	

Digital protractor

Compact digital protractor to attach to a caliper or height gauge.

- Measuring range: 180°.
- Resolution: 0.01° or 1'.
- Accuracy: ±5'.
- Digimatic data output.
- On/off switch.
- Automatic switch-off (adjustable).
- Preset or hold function.
- Reset.
- Reversible measuring direction.
- Weight: 160 g.
- Delivery in a wooden case including assembly key, mounting bracket (clamping shaft 9 x 9 mm) and clamping screw for height gauge.
- Power supply: 2 batteries type AAA.

MedioTehna



Item No.	Description	Price HRK
855.803	Digital protractor	
Options:		
497.914	Spare battery type AAA (2 needed)	
905.338	Digimatic cable, 1 m	
905.409	Digimatic cable, 2 m	

Measuring instruments set

For specifications see relevant pages elsewhere in this catalog.

- Digital caliper 906.838: measuring range 0- 150 mm, resolution 0.01 mm.
- Digital micrometer 906.862: measuring range 0- 25 mm, resolution 0.001 mm, with tolerance indication.
- Bevelled edge square 907.252: dimensions 100 x 70 mm, DIN 875/00.
- Delivery in a plastic carrying case.

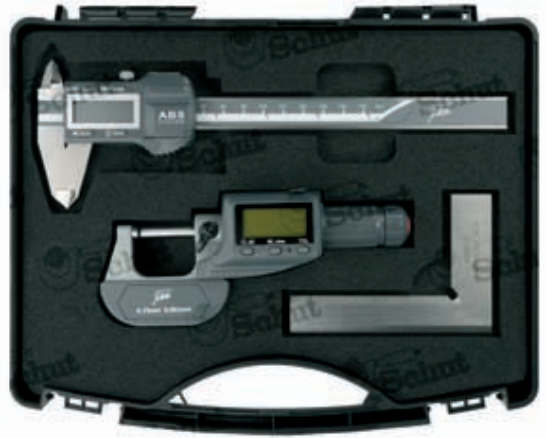

Item No.	Description	Price HRK
910.338	Meas. instruments set	

Measuring instruments set

For specifications see relevant pages elsewhere in this catalog.

- Caliper 909.521: measuring range 0- 150 mm, vernier 0.05 mm.
- Micrometer 906.000: measuring range 0- 25 mm, graduation 0.01 mm.
- Bevelled edge square 907.252: dimensions 100 x 70 mm, DIN 875/00.
- Ruler 835.421: measuring range 0- 150 mm, graduation 0.5 mm.
- Delivery in a plastic case.



Item No.	Description	Price HRK
910.339	Meas. instruments set	

Measuring instruments set

- Caliper: measuring range 0- 150 mm, vernier 0.02 mm.
- Micrometer: measuring range 0- 25 mm, graduation 0.01 mm.
- Bevelled edge square: dimensions 100 x 70 mm.
- Ruler: measuring range 0- 150 mm, 0- 50 mm: graduation 0.5 mm.
- Delivery in a plastic case.



Item No.	Description	Price HRK
906.176	Meas. instruments set	

Depth calipers

- Measuring range: 0 - 500 mm.
- Analog: vernier 0.02 mm, digital: resolution 0.01 mm.
- With or without hook (8 x 3 mm, l x w).
- Locking screw.

Analog

- Stainless steel construction.
- Matt chrome-plated beam and vernier.

Digital

- mm/inch conversion.
- On/off switch.
- Reset.
- Power supply: 1 battery type V357.

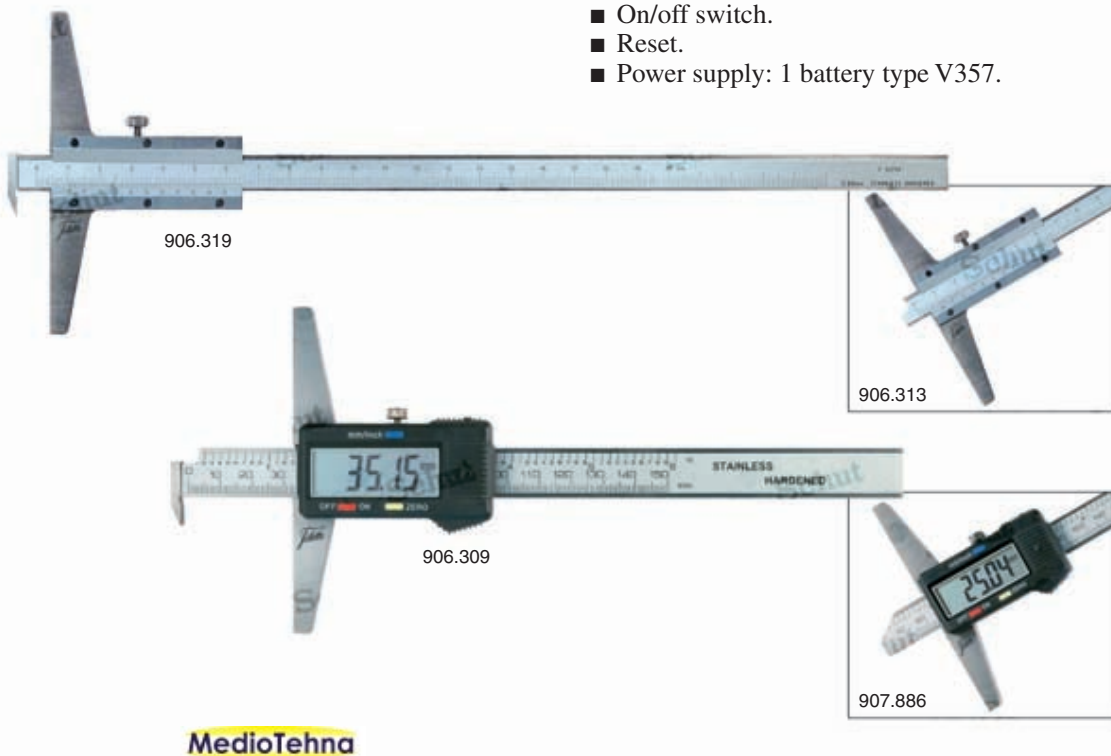

Analog

Item No.	Measuring range/mm	Base length/mm	Price HRK
Without hook:			
906.314	0 - 150	100	
906.313	0 - 200	100	
906.315	0 - 300	100	
906.317	0 - 500	100	
With hook:			
906.318	0 - 150	100	
906.319	0 - 200	100	
906.321	0 - 300	100	
906.322	0 - 500	100	

Digital

Item No.	Measuring range/mm	Base length/mm	Price HRK
Without hook:			
907.886	0 - 150	100	
907.887	0 - 200	100	
907.888	0 - 300	100	
907.898	0 - 500	100	
With hook:			
906.309	0 - 150	100	
906.310	0 - 200	100	
906.311	0 - 300	100	
906.312	0 - 500	100	
Option:			
836.535	Spare battery type V357		



Depth calipers

Depth calipers with or without hook.

- Measuring range: 0-300 mm.
- Vernier: 0.05 mm.
- Accuracy: ± 0.03 mm.
- Locking screw.
- Matt chrome-plated beam and vernier.
- Monoblock.
- Stainless steel construction.

MedioTehna

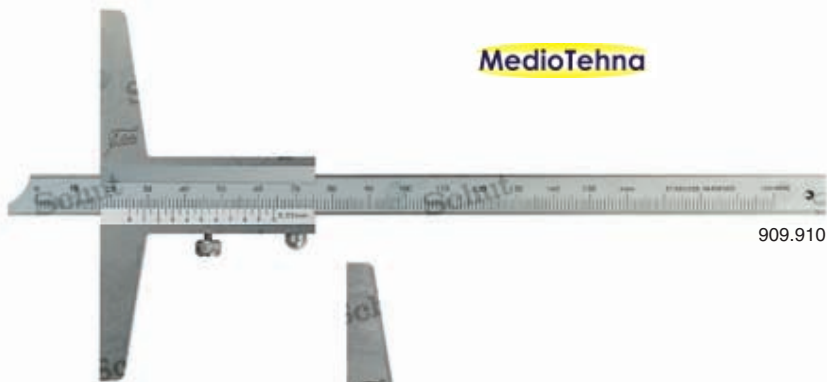

909.910



909.916

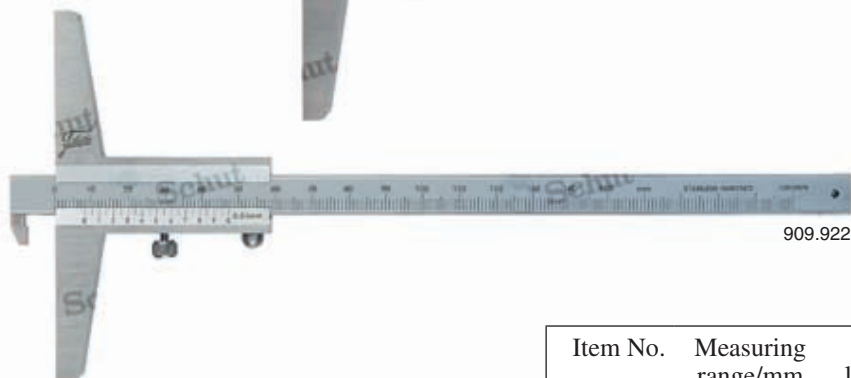

909.922

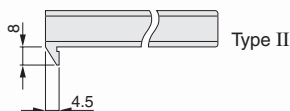
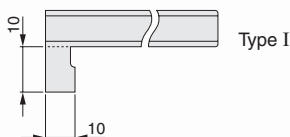

Item No.	Measuring range/mm	Base length/mm	Price HRK
Without hook:			
909.910	0-150	100	
909.911	0-200	100	
909.912	0-300	100	
With hook (type I):			
909.916	0-150	100	
909.917	0-200	100	
909.918	0-300	100	
With hook (type II):			
909.922	0-150	100	
909.923	0-200	100	
909.924	0-300	100	

Depth calipers

Waterproof, hardened stainless steel depth calipers, in different versions of the beam's measuring face. Suited for use with removable bridges.

- Measuring range: 0-800 mm.
- Resolution: 0.01 mm.
- Accuracy: ± 0.03 mm or ± 0.04 mm.
- Proximity data output.
- On/off switch.
- Automatic switch-off.
- Reset/preset.
- Hold function.
- Locking screw.
- Protection: IP67.
- Standard supplied with insert 839.077.
- Conforms to factory standard.
- Delivery in a wooden case with a manufacturer measuring report.
- Power supply: 1 battery type CR2032.

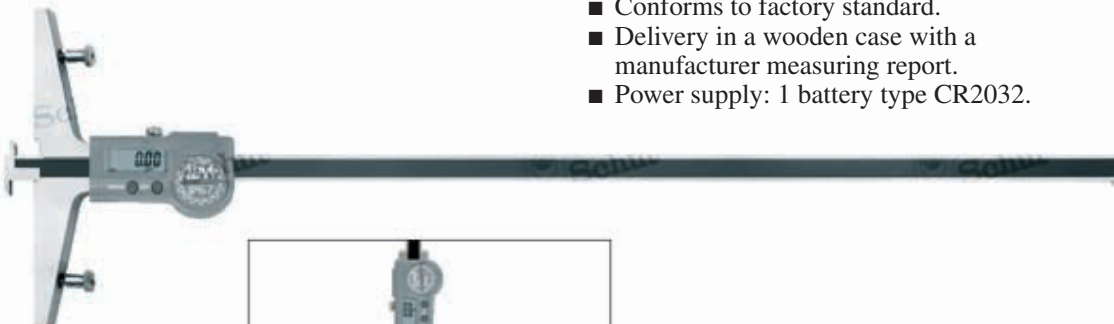

MedioTehna

Item No.	Measuring range/mm	Accuracy mm	Price HRK
839.069	0-300	± 0.03	
839.070	0-400	± 0.03	
839.071	0-500	± 0.03	
839.072	0-600	± 0.03	
839.073	0-800	± 0.04	

Option:

- 495.157 Spare battery type CR2032
- 840.666 Proximity USB cable (2 m)

Removable bridges

Item No.	Length/mm	Price HRK
839.074	400	
839.075	500	
839.076	600	

Inserts

Item No.	Description	Price HRK
839.077	Insert	
839.079	Insert	
839.080	Insert	
839.081	Insert	
839.082	Insert	
839.083	Insert	
839.078	Insert	

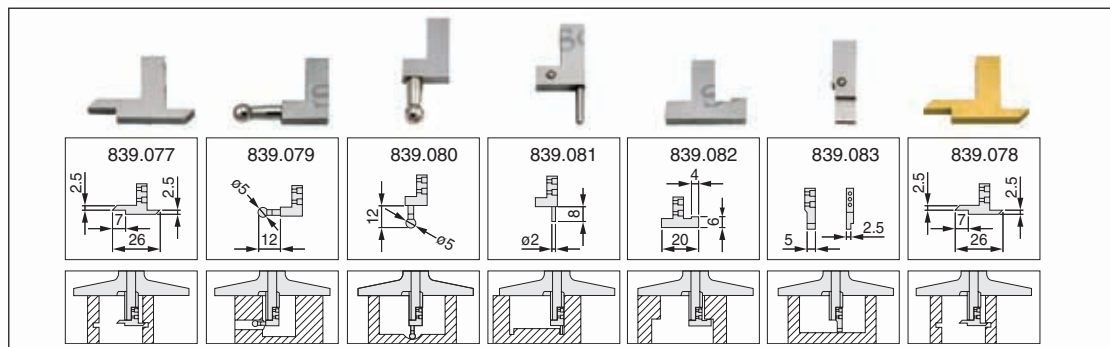

Digital lightweight depth caliper

Universal lightweight aluminum depth caliper with two interchangeable measuring inserts set at 90° and 3 measuring bases. All inserts with M2.5 thread can be used with these calipers. Please see the dial indicator accessories section for these inserts. Excellent sliding properties due to double prismatic joint.

- Measuring range: 0-500 mm.
- Resolution: 0.01 mm.
- mm/inch conversion.
- On/off switch.
- Reset.
- Length included measuring bases: 150, 300 and 450 mm.
- Interchangeable measuring inserts: 2 measuring inserts included (ball attachments $\phi 3.2$ mm, $l=6$ mm and $\phi 5$ mm, $l=12$ mm).
- Locking screw.
- Delivery in a plastic case with a manufacturer measuring report.
- Power supply: 1 battery type V357.

Item No.	Measuring range/mm	Accuracy mm	Weight kg	Price HRK
853.210	0-500	0.05	0.5	
Option:				
836.535	Spare battery type V357			



Digital lightweight depth calipers with with round depth rod

Universal lightweight aluminum depth calipers with round depth rod and M2.5 threaded hole for interchangeable inserts. Inserts with M2.5 thread can be used with these calipers. Please see the dial indicator accessories section for these inserts. Excellent sliding properties due to double prismatic joint.

- Measuring range: 0-500 mm.
- Diameter depth rod: Measuring range 0-300 mm $\phi 4$ mm Measuring range 500 mm $\phi 6$ mm.
- Resolution: 0.01 mm.
- mm/inch conversion.
- On/off switch.
- Reset.
- Length included measuring base: 350 mm.
- Interchangeable measuring inserts: 2 measuring inserts included (ball attachment $\phi 3.2$ mm, $l=6$ mm and disc attachment $\phi 10$ mm, $d=2$ mm at 0-300 mm or disc attachment $\phi 20$ mm, $d=2$ mm at 500 mm).
- Locking screw.
- Delivery in a plastic case with a manufacturer measuring report.
- Power supply: 1 battery type V357.



Item No.	Measuring range/mm	Accuracy mm	Weight kg	Price HRK
853.212	0-200	0.03	0.3	
853.213	0-300	0.04	0.4	
853.214	0-500	0.05	0.6	
Options:				
836.535	Spare battery type V357			
853.222	Measuring base 550 mm			
853.223	Measuring base 750 mm			
853.224	Measuring base 950 mm			

Digital depth calipers with with round depth rod

Universal depth calipers with round depth rod with M2.5 threaded hole for exchangeable inserts. Inserts with M2.5 thread can be used with these calipers. Please see the dial indicator accessories section for these inserts.

- Measuring range: 0- 150 mm.
- Diameter depth rod: 4 mm.
- Resolution: 0.01 mm.
- mm/inch conversion.
- On/off switch.
- Reset.
- Large LCD display.
- Locking screw.
- Length measuring base: 85 mm.
- Interchangeable measuring inserts: disc attachment included $\varnothing 8$ mm, $d=1$ mm.
- Power supply: 1 battery type V357.



Item No.	Measuring range/mm	Price HRK
910.355	0- 100	
910.356	0- 150	
Option:		
836.535	Spare battery type V357	

MedioTehna

Digital depth gauge

- Measuring range: 0- 21.5 mm.
- Resolution: 0.01 mm.
- mm/inch conversion.
- On/off switch.
- Reset.
- Locking screw.
- Measuring face: 45 x 6 mm.
- Measuring pin: 6 x 2.3 mm, taper to 4 x 2.3 mm.
- Power supply: 1 battery type V357.



Item No.	Measuring range/mm	Price HRK
907.861	0- 21.5	
Option:		
836.535	Spare battery type V357	

Digital depth gauge

Digital tire tread depth gauge made of high quality plastic.

- Measuring range: 0- 25 mm.
- Resolution: 0.01 mm.
- mm/inch conversion.
- On/off switch.
- Reset.
- Large LCD display.
- Measuring face: 60 x 5.7 mm.
- Measuring pin: $\varnothing 4$ mm.
- Measuring tip: 2.6 x 0.9 mm.
- Power supply: 1 battery type V357.



Item No.	Measuring range/mm	Price HRK
910.357	0- 25	
Option:		
836.535	Spare battery type V357	

Depth caliper for keyway depths

- Measuring range: keyway depths 0-25 mm.
- Application range: cylinders ϕ 5-200 mm.
- Resolution: 0.01 mm.
- mm/inch conversion.
- On/off switch.
- Reset.
- Large LCD display.
- Locking screw.
- Measuring pin: ϕ 2 mm.
- Power supply: 1 battery type V357.



Item No.	Application range/mm	Price
910.258	ϕ 5-200	
Option:		
836.535	Spare battery type V357	

Depth calipers for keyway depths

- Measuring range: keyway depths 0-60 mm.
- Application range: cylinders ϕ 5-200 mm.
- Vernier: 0.05 mm.
- Stainless steel construction.



Item No.	Application range/mm	Price HRK
907.192	ϕ 5-80	
907.193	ϕ 6-120	
907.194	ϕ 7-160	
907.195	ϕ 8-200	

Digital depth gauge

- Measuring range: 0-80 mm.
- Resolution: 0.05 mm.
- mm/inch conversion.
- On/off switch.
- Detachable measuring pin ϕ 4.3 mm, length 50 mm.
- Power supply: 1 battery type CR2032.



MedioTehna



Item No.	Measuring range/mm	Price HRK
906.428	0-80	
Option:		
495.157	Spare battery type CR2032	

Käfer depth dial indicators

- Measuring range: 0-30 mm.
- Graduation: 0.01 mm.
- Measuring pin shaft: ϕ 2 mm.
- Measuring depth with pin 852.385: 200 mm.
- Excl. measuring pin and measuring base.
- Accuracy according DIN 878 (852.383) or factory standard (852.384).



Item No.	Measuring range/mm	Price HRK
852.383	0-10	
852.384	0-30	
Options:		
852.385	Measuring pin ϕ 2 mm, 340 mm	
907.153	Meas. base 63 x 17 mm	
907.165	Meas. base 101.5 x 17 mm*	

* Larger sizes available on request.

Micrometers / Micrometer heads



Digital micrometers

Rugged digital micrometers with simple functions and an excellent price-performance ratio.

- Measuring range: 0-200 mm.
- Resolution: 0.001 mm.
- Automatic switch-off.
- Reset/preset.
- Tungsten carbide measuring faces: $\varnothing 6.5$ mm.
- From measuring range 25-50 mm including setting gauge.
- Power supply: 1 battery type V357.



MedioTehna



908.769



Item No.	Measuring range/mm	Accuracy mm	Price HRK
Not switchable:			
908.752	50- 75	± 0.005	
908.753	75- 100	± 0.005	
908.755	125- 150	± 0.006	
Switchable mm/inch and ABS/INC:			
908.758	0- 25	± 0.004	
908.759	25- 50	± 0.004	
908.760	50- 75	± 0.005	
908.761	75- 100	± 0.005	
908.762	100- 125	± 0.006	
908.763	125- 150	± 0.006	
908.764	150- 175	± 0.007	
908.765	175- 200	± 0.007	

Sets

Item No.	Measuring range/mm	Pieces	Price HRK
Switchable mm/inch and ABS/INC:			
908.769	0- 75	3	
908.770	0-100	4	
908.771	0-150	6	

Option

Item No.	Description	Price HRK
836.535	Spare battery type V357	

Digital micrometers

Rugged digital micrometers with simple functions and an excellent price-performance ratio.

- Measuring range: 0- 150 mm.
- Resolution: 0.001 mm.
- mm/inch conversion.
- ABS/INC switchable.
- Automatic switch-off.
- Reset/preset.
- Tungsten carbide measuring faces: $\phi 6.5$ mm.
- From measuring range 25 - 50 mm including setting gauge.

- Delivery in a plastic case with a manufacturer measuring report.
- Power supply: 1 battery type CR2032.



Item No.	Measuring range/mm	Accuracy mm	Price HRK
909.982	0- 25	± 0.003	
909.983	25- 50	± 0.003	
909.984	50- 75	± 0.004	
909.985	75- 100	± 0.004	
909.986	100- 125	± 0.005	
909.987	125- 150	± 0.005	

Option:
495.157 Spare battery type CR2032

Digital micrometers with double display

This patented micrometer distinguishes itself with its two large displays on both sides of the instrument, which can also display the read-out upside-down. Therefore the measuring value can always be presented upright, which enables ergonomic read-out at all times. Add to this its measuring range of 30 mm, the tungsten carbide measuring faces and you have a micrometer with a great price-performance ratio.

- Measuring range: 0- 205 mm.
- Resolution: 0.001 mm.
- mm/inch conversion.
- ABS/INC switchable.
- Double LCD display.
- Second display can be switched on/off separately.

MedioTehna

- Automatic switch-off.
- Reset/preset.
- Tungsten carbide measuring faces: $\phi 6.5$ mm.
- From measuring range 25 - 55 mm including setting gauge.
- Delivery in a plastic case.
- Power supply: 1 battery type CR2032.



Measuring value 'upside-down'.



Item No.	Measuring range/mm	Accuracy mm	Price HRK
907.682	0- 30	± 0.004	
907.683	25- 55	± 0.004	
907.684	50- 80	± 0.005	
907.685	75- 105	± 0.005	
907.686	100- 130	± 0.006	
907.687	125- 155	± 0.006	
907.688	150- 180	± 0.007	
907.689	175- 205	± 0.007	

Option:
495.157 Spare battery type CR2032

Digital micrometers with tolerance indication

These absolute digital micrometers are provided with both a tolerance and a hold function, as well as a large display.

- Measuring range: 0- 75 mm.
- Resolution: 0.001 mm.
- mm/inch conversion.
- ABS/INC switchable.
- Digit height: 9 mm.
- Automatic switch-off.
- Reset/preset.
- Hold function.
- Adjustable tolerance limits.
- Tungsten carbide measuring faces: $\varnothing 6.5$ mm.
- Power supply: 1 battery type V357.



907.570

MedioTehna



Item No.	Measuring range/mm	Accuracy mm	Price HRK
907.570	0- 25	± 0.004	
907.571	25- 50	± 0.004	
907.572	50- 75	± 0.005	
Option:			
836.535	Spare battery type V357		

Micrometers with counter

These solid micrometers have a counter with a resolution of 0.01 mm for an error free read-out of the measuring value, and a very favourable price-performance ratio.

- Measuring range: 0- 200 mm.
- Resolution: 0.01 mm.
- Numerical counter adjustable.
- Tungsten carbide measuring faces: $\varnothing 6.5$ mm.
- Delivery with adjustment tool.
- From measuring range 25 - 50 mm including setting gauge.



906.556



Sets (delivered incl. setting gauges)

Item No.	Measuring range/mm	Pieces	Price HRK
906.564	0- 75	3	
906.565	0- 100	4	
906.566	0- 150	6	

Item No.	Measuring range/mm	Accuracy mm	Price HRK
906.556	0- 25	± 0.01	
906.557	25- 50	± 0.01	
906.558	50- 75	± 0.01	
906.559	75- 100	± 0.01	
906.560	100- 125	± 0.02	
906.561	125- 150	± 0.02	
906.562	150- 175	± 0.02	
906.563	175- 200	± 0.02	

Absolute digital micrometers with tolerance indication IP54

Digital micrometers with a function to set tolerance limits with clear optical Go (NoGo) reading.

- Measuring range: 0- 100 mm.
- Resolution: 0.001 mm.
- mm/inch conversion.
- ABS/INC switchable.
- With data output.
- Adjustable tolerance limits.
- **Tolerance display** by means of illuminated green LED at GO value.
- On/off switch.
- Automatic switch-off.
- Reset.
- Tungsten carbide measuring faces: $\varnothing 6.5$ mm.
- Protection: IP54.
- Delivery in a plastic case with a manufacturer measuring report.
- Power supply: 1 battery type CR2032.



906.862

USB interface:

- For data transfer to PC (e.g. Excel, Word).
- Operating system: Windows and other.
- PC connection: USB.
- No software or driver to install.
- Foot switch (optional).



906.618



909.687



906.619/910.038

Item No.	Measuring range/mm	Accuracy mm	Price HRK
906.862	0 - 25	± 0.003	
906.863	25 - 50	± 0.003	
906.864	50 - 75	± 0.004	
906.865	75 - 100	± 0.004	

Options:

- 495.157 Spare battery type CR2032
- 906.618^{1,2} USB interface
- 909.687 Footswitch for USB interface
- 910.038 Wireless USB receiver
- 906.619² Wireless transmitter

¹ Standard configured for PC with English (US) keyboard. Also available on request for alternative keyboards.

² With micro-USB connection.

Digital micrometers IP54

- Measuring range: 0 - 150 mm.
- Resolution: 0.001 mm.
- mm/inch conversion.
- Automatic switch-off.
- Reset.
- Tungsten carbide measuring faces: $\varnothing 6.5$ mm.
- Protection: IP54.
- From measuring range 25 - 50 mm including setting gauge.
- Delivery in a plastic case.
- Power supply: 1 battery type V357.



910.041

MedioTehna

Sets

Item No.	Measuring range/mm	Pieces	Price HRK
910.053	0 - 75	3	
910.055	0 - 150	6	

Item No.	Measuring range/mm	Accuracy mm	Price HRK
910.041	0 - 25	± 0.004	
910.042	25 - 50	± 0.004	
910.043	50 - 75	± 0.005	
910.044	75 - 100	± 0.005	
910.045	100 - 125	± 0.006	
910.046	125 - 150	± 0.006	

Option:

836.535 Spare battery type V357

Digital micrometers IP65

These IP65 protected micrometers are especially suitable for use in production environments.

- Measuring range: 0 - 100 mm.
- Resolution: 0.001 mm.
- mm/inch conversion.
- ABS/INC switchable.
- On/off switch.
- Automatic switch-off.
- Reset.
- Tungsten carbide measuring faces: $\varnothing 6.5$ mm.
- Protection: IP65.
- From measuring range 25 - 50 mm including setting gauge.
- Delivery in a plastic case with a manufacturer measuring report and ball attachment.
- Power supply: 1 battery type CR2032.



909.988



Item No.	Measuring range/mm	Accuracy mm	Price HRK
909.988	0 - 25	± 0.003	
909.989	25 - 50	± 0.003	
909.990	50 - 75	± 0.004	
909.991	75 - 100	± 0.004	

Option:

495.157 Spare battery type CR2032

Digital fast adjustable external measuring instruments IP65

These digital external measuring instruments have an IP65 classification and are therefore not only resistant to dust, but can also withstand water jets. The non-rotating spindle is solely lever operated and fast adjustable.

- Measuring range: 0- 100 mm.
- Resolution: 0.001 mm.
- mm/inch conversion.
- ABS/INC switchable.
- Digimatic data output.
- On/off switch.
- Reset.
- Non-rotating spindle.
- Tungsten carbide measuring faces: $\varnothing 6.5$ mm.
- Protection: IP65.
- From measuring range 25 - 50 mm including setting gauge.
- Delivery in a plastic case with a manufacturer measuring report and ball attachment.
- Power supply: 1 battery type CR2032.

MedioTehna



909.994

USB interface:

- For data transfer to PC (e.g. Excel, Word).
- Operating system: Windows and other.
- PC connection: USB.
- No software or driver to install.
- Foot switch (optional).



909.686



909.687



910.039/038



Item No.	Measuring range/mm	Accuracy mm	Price HRK
909.994	0- 25	± 0.003	
909.995	25 - 50	± 0.003	
909.996	50 - 75	± 0.004	
909.997	75 - 100	± 0.004	

With Bluetooth:

910.075	0- 25	± 0.003	
---------	-------	-------------	--

Options:

- 495.157 Spare battery type CR2032
- 909.686^{1,2} USB interface
- 909.687 Footswitch for USB interface
- 910.038 Wireless USB receiver
- 910.039² Wireless transmitter

¹ Standard configured for PC with English (US) keyboard. Also available on request for alternative keyboards.

² For instruments with a Digimatic data output.

Digital micrometers IP65

These digital micrometers have an IP65 classification and are therefore not only resistant to dust but can also withstand water jets. Also available as fast adjustable micrometers with a pitch of 2 mm.

- Measuring range: 0- 300 mm.
- Resolution: 0.001 mm.
- mm/inch conversion.
- ABS/INC switchable.
- With data output.
- On/off switch.
- Automatic switch-off.
- Tungsten carbide measuring faces: $\varnothing 6.5$ mm.
- Protection: IP65.
- From measuring range 25 - 50 mm including setting gauge.
- Delivery in a plastic case or a wooden case.
- Power supply: 1 battery type V357.

Fast adjustable micrometers

- 1 revolution of the thimble = 2 mm.



909.549



909.545

MedioTehna

Fast adjustable micrometers



Item No.	Measuring range/mm	Accuracy mm	Price HRK
909.549	0- 25	± 0.002	
909.550	25- 50	± 0.002	
909.551	50- 75	± 0.003	
909.552	75- 100	± 0.003	
909.556	100- 125	± 0.003	
909.557	125- 150	± 0.003	
909.558	150- 175	± 0.004	
909.559	175- 200	± 0.004	
909.560	200- 225	± 0.004	
909.561	225- 250	± 0.004	
909.562	250- 275	± 0.005	
909.563	275- 300	± 0.005	

Options:

- 836.535 Spare battery type V357
- 910.458 Bluetooth transmitter

Item No.	Measuring range/mm	Accuracy mm	Price HRK
909.545	0- 25	± 0.002	
909.546	25- 50	± 0.002	
909.547	50- 75	± 0.003	
909.548	75- 100	± 0.003	

Sets

Item No.	Measuring range/mm	Pieces	Price HRK
909.577	0- 75	3	
909.578	0- 100	4	
909.579	0- 150	6	



Micrometers

- Measuring range: 0 - 300 mm.
- Graduation: 0.01 mm.
- Friction thimble.
- Tungsten carbide measuring faces: $\phi 6.5$ mm.
- From measuring range 25 - 50 mm including setting gauge.



MedioTehna



906.059



906.057



906.056



Item No.	Measuring range/mm	Accuracy mm	Price HRK
906.000	0 - 25	± 0.004	
906.001	25 - 50	± 0.004	
906.002	50 - 75	± 0.005	
906.003	75 - 100	± 0.005	
906.004	100 - 125	± 0.006	
906.005	125 - 150	± 0.006	
906.006	150 - 175	± 0.007	
906.007	175 - 200	± 0.007	
906.008	200 - 225	± 0.008	
906.009	225 - 250	± 0.008	
906.010	250 - 275	± 0.009	
906.011	275 - 300	± 0.009	

Sets

Item No.	Measuring range/mm	Price HRK
906.055	0 - 75	
906.056	0 - 100	
906.057	0 - 150	
906.058	150 - 300	
906.059	0 - 300	

Model for left- and right-handed use:

907.167	0 - 25	± 0.004
907.168	25 - 50	± 0.004
907.169	50 - 75	± 0.005
907.170	75 - 100	± 0.005



Micrometers 0.001 mm, parallax-free

Rugged micrometers with a vernier graduation of 0.001 mm and a favourable price-performance ratio.

- Measuring range: 0-200 mm.
- Vernier: 0.001 mm, parallax-free by enlarged thimble.
- Friction thimble.
- Tungsten carbide measuring faces: $\varnothing 6.5$ mm.
- Delivery incl. adjustment tool.
- From measuring range 25 - 50 mm including setting gauge.



906.280

Item No.	Measuring range/mm	Accuracy mm	Price HRK
906.280	0- 25	± 0.004	
906.281	25- 50	± 0.004	
906.282	50- 75	± 0.005	
906.283	75-100	± 0.005	
906.284	100-125	± 0.006	
906.285	125-150	± 0.006	
906.286	150-175	± 0.007	
906.287	175-200	± 0.007	

Fast adjustable micrometers

Fast adjustable micrometers due to one revolution resulting in a displacement of 1 mm. The measuring value can be read directly from the 100 step graduation on the thimble.

- Measuring range: 0-200 mm.
- Graduation: 0.01 mm.
- 1 revolution of the thimble = 1 mm.
- Thimble with 100 step graduation.
- Tungsten carbide measuring faces: $\varnothing 8$ mm.
- From measuring range 25 - 50 mm including setting gauge.



907.000

Item No.	Measuring range/mm	Accuracy mm	Price HRK
907.000	0- 25	± 0.004	
907.001	25- 50	± 0.004	
907.002	50- 75	± 0.005	
907.003	75-100	± 0.005	
907.004	100-125	± 0.006	
907.005	125-150	± 0.006	
907.006	150-175	± 0.007	
907.007	175-200	± 0.007	

MedioTehna

Micrometers with a large measuring range

The varnished tubular frame is very stable and equipped with heat insulating grips. With two spacers for a large measuring span.

- Measuring range: 300 - 2000 mm.
- Measuring span:
 - 300 - 1000 mm: 100 mm (travel 25 mm, spacers 25 and 50 mm),
 - 1000 - 2000 mm: 200 mm (travel 50 mm, spacers 50 and 100 mm).
- Graduation: 0.01 mm.
- Rotating spindle.
- Tungsten carbide measuring faces: $\varnothing 8$ mm.
- Matt chrome-plated thimble.
- With two setting gauges.

Item No.	Measuring range/mm	Accuracy mm	Price HRK
Measuring span 100 mm:			
906.012	300 - 400	± 0.011	
906.013	400 - 500	± 0.013	
906.014	500 - 600	± 0.015	
906.015	600 - 700	± 0.016	
906.016	700 - 800	± 0.018	
906.017	800 - 900	± 0.020	
906.018	900 - 1000	± 0.020	
Measuring span 200 mm:			
906.019	1000 - 1200	± 0.020	
906.020	1200 - 1400	± 0.024	
906.021	1400 - 1600	± 0.028	
906.022	1600 - 1800	± 0.031	
906.023	1800 - 2000	± 0.034	

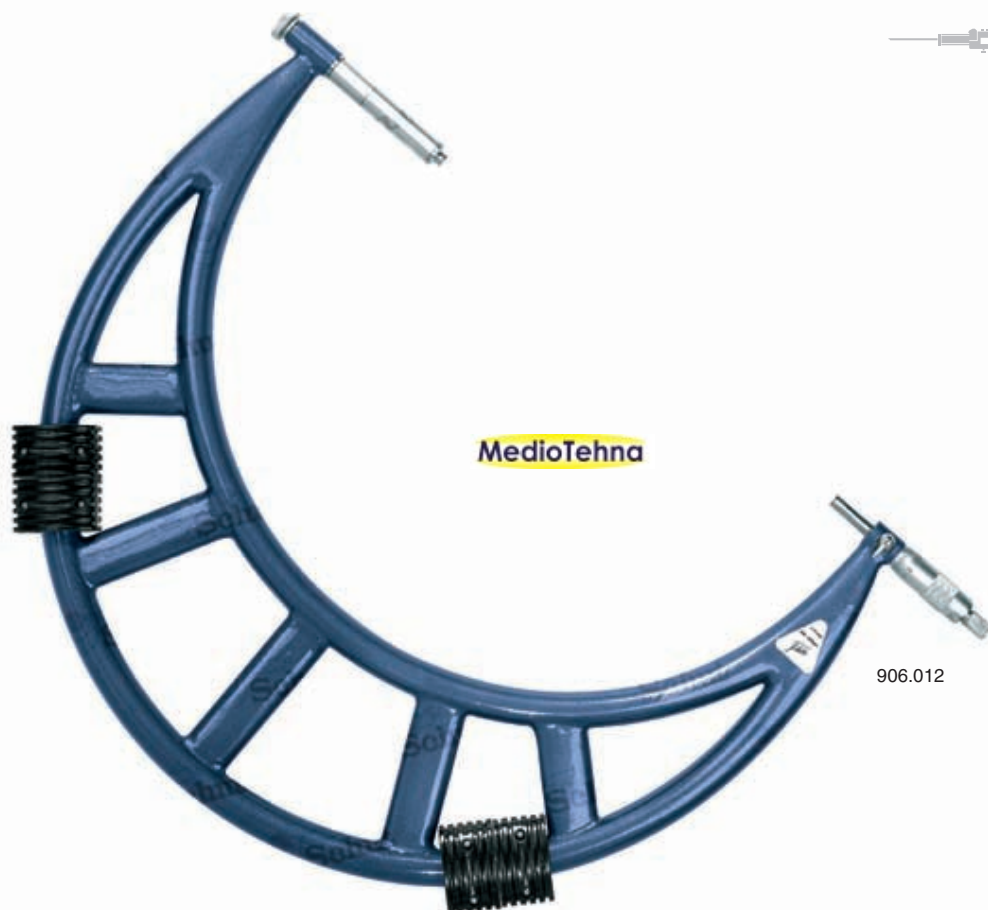

Delivery ex Groningen, Netherlands

Micrometers with a large measuring range

Micrometers with a large measuring range, with very accurate, interchangeable anvils.

- Measuring range: 0-300 mm.
- Graduation: 0.01 mm.
- Tungsten carbide measuring faces: $\varnothing 6.35$ mm.
- Delivery in a plastic case, incl. setting gauges and interchangeable anvils (increasing per 25 mm).



906.290



Item No.	Measuring range/mm	Accuracy mm	Number of anvils	Number of setting gauges	Price HRK
906.290	0- 50	± 0.004	2	1	
906.294	0- 100	± 0.005	4	3	
906.292	0- 150	± 0.006	6	5	
906.291	50- 100	± 0.005	2	2	
906.295	100- 200	± 0.007	4	4	
906.293	150- 300	± 0.009	6	6	
906.296	200- 300	± 0.009	4	4	

Micrometers with adjustable anvil with dial indicator

Micrometers with an adjustable anvil with dial indicator, for measurements in a wide measuring range.

- Measuring range: 0- 1000 mm.
- Graduation: 0.01 mm.
- Tungsten carbide measuring faces: $\varnothing 8$ mm.
- Delivery in a plastic case.

Specifications dial indicator:

- Graduation: 0.01 mm.
- Range adjustable anvil: 5 mm.
- Max. measuring force anvil with dial indicator: 10 N.
- Adjustable tolerance markers.



907.015

Item No.	Measuring range/mm	Accuracy mm	Price HRK
907.015	0- 100	± 0.006	
907.016	100- 200	± 0.007	
907.017	200- 300	± 0.008	
907.018	300- 400	± 0.009	
907.019	400- 500	± 0.010	
907.020	500- 600	± 0.011	
907.021	600- 700	± 0.012	
907.022	700- 800	± 0.013	
907.023	800- 900	± 0.014	
907.024	900- 1000	± 0.015	

MedioTehna

Digital micrometers IP65 with a large measuring range

- Measuring range: 0 - 1000 mm.
- Resolution: 0.001 mm.
- mm/inch conversion.
- ABS/INC switchable.
- Automatic switch-off.
- Reset/preset.
- Rotating spindle.
- Adjustable tolerance limits.
- Tungsten carbide measuring faces: $\varnothing 6.35$ mm.
- 0 - 300 mm: cast iron frame, 300 - 1000 mm: tubular steel frame with insulating grips.
- Protection: IP65.
- Delivery in a wooden case with setting gauges interchangeable anvils.
- Power supply: 1 battery type V357.

MedioTehna



909.580



Item No.	Measuring range/mm	Accuracy mm	Number of anvils	Number of setting gauges	Price HRK
909.580	0 - 100	± 0.005	4	3	
909.581	100 - 200	± 0.007	4	4	
909.582	200 - 300	± 0.008	4	4	
909.583	300 - 400	± 0.009	4	2	
909.584	400 - 500	± 0.010	4	2	
909.585	500 - 600	± 0.010	4	2	
909.586	600 - 700	± 0.011	4	2	
909.587	700 - 800	± 0.012	4	2	
909.588	800 - 900	± 0.013	4	2	
909.589	900 - 1000	± 0.013	4	2	
Option:					
836.535	Spare battery type V357				

Micrometers with dial indicator

Micrometers with adjustable anvil and clamping shaft for a dial indicator. Especially suitable for Go/NoGo determination and batch measurements.

- Measuring range: 0- 175 mm.
- Graduation thimble and dial indicator: 0.01 mm.
- Range adjustable anvil: 8 mm.
- Trigger for (fast) adjustment.
- Tungsten carbide measuring faces: $\varnothing 6.5$ mm.
- Delivery in a wooden case.
- Can also be used in combination with various other dial indicators with clamping stem $\varnothing 8$ mm.



MedioTehna

Item No.	Measuring range/mm	Accuracy mm	Price HRK
907.008	0- 25	± 0.004	
907.009	25- 50	± 0.004	
907.010	50- 75	± 0.005	
907.011	75-100	± 0.005	
907.012	100-125	± 0.006	
907.013	125-150	± 0.006	
907.014	150-175	± 0.007	

Mini-micrometer

- Measuring range: 0- 15 mm.
- Graduation: 0.01 mm.
- Measuring faces: $\varnothing 5$ mm.
- Without friction thimble.
- Dimensions:
total length: 70 mm,
throat depth: 14 mm.
- Delivery in a plastic case.



Item No.	Measuring range/mm	Price HRK
906.180	0- 15	

Micrometer with an extra large measuring range

The measuring range of this micrometer can be 'switched' from 25- 50 to 0-25 mm by easy mounting of the extension anvil.

- Measuring range: 0- 50 mm.
- Graduation: 0.01 mm.
- Accuracy: ± 0.004 mm.
- Tungsten carbide measuring faces: $\varnothing 6.5$ mm.
- Delivery in a wooden case, incl. adjustment tool and extension anvil.



Item No.	Measuring range/mm	Accuracy mm	Price HRK
906.567	0- 50	± 0.004	

Tolerance micrometers with precision dial indicator

Because of the retractable anvil, the fine adjustment and the tolerance markers, this micrometer is very suitable for batch inspection and tolerance measurements.

- Measuring range: 0- 100 mm.
- Measuring range dial indicator: ± 0.04 mm.
- Graduation (dial indicator): 0.001 mm.
- Accuracy:
micrometer: ± 0.003 mm (only 906.568),
dial indicator: ± 0.001 mm.
- Measuring force: 5- 10 N
(only 906.569/570/571/614).
- Adjustable tolerance markers.
- Tungsten carbide measuring faces:
906.568-599: $\phi 6.5$ mm,
906.569-614: $\phi 10$ mm.
- Delivery in an aluminum case.

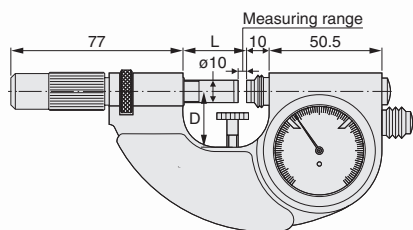

Item No.	D/mm	L/mm
906.569	25	28.5
906.570	35	53.5
906.571	47.5	78.5
906.614	60	103.5

Item No.	Measuring range/mm	Graduation mm	Vernier thimble/mm	Price HRK
906.568	0- 25	0.001	0.002	
906.597	25- 50	0.001	—	
906.598	50- 75	0.001	—	
906.599	75-100	0.001	—	

With protection IP54:

906.569	0- 25	0.001	—	
906.570	25- 50	0.001	—	
906.571	50- 75	0.001	—	
906.614	75-100	0.001	—	

Tolerance micrometers with two spindles

Can be used as a Go/NoGo micrometer by setting of the lower and upper limits.



- Measuring range: 0- 50 mm.
- Vernier: 0.002 mm.
- Accuracy: ± 0.003 mm.
- Tungsten carbide measuring faces: $\phi 6.5$ mm.

MedioTehna

Item No.	Measuring range/mm	Accuracy mm	Price HRK
906.288	0- 25	± 0.003	
906.289	25- 50	± 0.003	

Dial snap gauges

Snap gauges with adjustable anvil and clamping shaft for a dial indicator. Especially suitable for Go/NoGo determination and batch measurements.

- Measuring range: 0- 300 mm.
- Measuring force: 6-9 N.
- Clamping shaft: $\varnothing 8$ mm (dial gauge not included).
- Travel of moving anvil: 3 mm.
- Anvil size: 14 x 11 mm.
- Chamfered anvils for easy insertion.
- Delivery in a wooden case.

- For suitable dial indicators refer to the dial indicators elsewhere in this catalog.



Item No.	Measuring range/mm	Length/mm		Price HRK
		A	B	
906.237	0- 25	42	20	
906.238	25- 50	69	32.5	
906.239	50- 75	94	45	
906.240	75- 100	119	57.5	
906.241	100- 125	144	70	
906.242	125- 150	169	82.5	
906.243	150- 175	194	95	
906.244	175- 200	219	107.5	
906.245	200- 225	244	120	
906.246	225- 250	269	132.5	
906.247	250- 275	294	145	
906.248	275- 300	319	157.5	

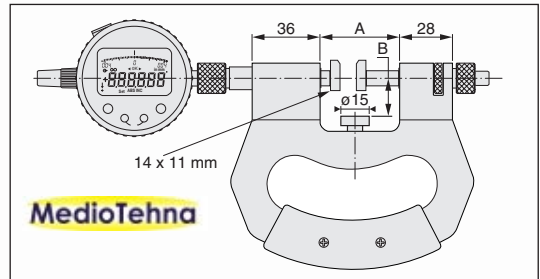

Digital vertical micrometers

Digital vertical micrometers for easy reading, for example, when measuring the thickness of metal or plastic sheet. These micrometers have an IP65 classification and are therefore not only resistant to dust but can also withstand water jets.

- Measuring range: 0- 50 mm.
- Resolution: 0.001 mm.
- Accuracy: ± 0.002 mm.
- mm/inch conversion.
- ABS/INC switchable.

- On/off switch.
- Automatic switch-off.
- Tungsten carbide measuring faces: $\varnothing 6.5$ mm.
- Protection: IP65.
- Delivery in a wooden case.
- Power supply: 1 battery type V357.



Item No.	Measuring range/mm	Price HRK
909.458	0- 25	
909.459	25- 50	
Option:		
836.535	Spare battery type V357	

Micrometers with small measuring faces

For measuring hard-to-reach measuring points such as grooves.

- Measuring range: 0- 175 mm.
- Analog: graduation 0.01 mm, digital: resolution 0.001 mm.
- Tungsten carbide measuring pins: $\varnothing 2 \times 5$ mm.
- Delivery in a plastic case.

Digital

- mm/inch conversion.
- ABS/INC switchable.
- Reset/preset.
- Protection: IP65.
- Power supply: 1 battery type V357.

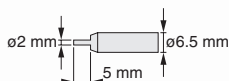

MedioTehna



Analog

Item No.	Measuring range/mm	Accuracy mm	Price HRK
906.135	0- 25	± 0.004	
906.136	25- 50	± 0.004	
906.137	50- 75	± 0.005	
906.119	75- 100	± 0.005	
909.320	100- 125	± 0.006	
909.321	125- 150	± 0.006	
909.322	150- 175	± 0.007	

Digital

Item No.	Measuring range/mm	Accuracy mm	Price HRK
909.591	0- 25	± 0.002	
909.592	25- 50	± 0.002	
909.593	50- 75	± 0.003	
909.594	75- 100	± 0.003	
909.595	100- 125	± 0.003	
909.596	125- 150	± 0.003	
909.597	150- 175	± 0.004	

Option:

836.535 Spare battery type V357



Micrometers with spherical anvil

Micrometers for measuring bent surfaces and wall thicknesses of tubes, bearings, rings, etc.

- Measuring range: 0- 100 mm.
- Analog: graduation 0.01 mm, digital: resolution 0.001 mm.
- Tungsten carbide measuring faces: $\phi 6.5$ mm.
- Delivery in a plastic case.

Digital

- mm/inch conversion.
- ABS/INC switchable.
- On/off switch.
- Automatic switch-off.
- Reset/preset.
- Protection: IP65.
- Power supply: 1 battery type V357.



906.155

MedioTehna



909.598

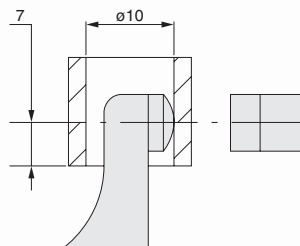

Analog

Item No.	Measuring range/mm	Accuracy mm	Price HRK
906.155	0- 25	± 0.004	
907.044	25- 50	± 0.004	
907.045	50- 75	± 0.005	
907.046	75- 100	± 0.005	

Digital

Item No.	Measuring range/mm	Accuracy mm	Price HRK
909.598	0- 25	± 0.002	
909.599	25- 50	± 0.002	
909.600	50- 75	± 0.003	
909.601	75- 100	± 0.003	

Option:

836.535 Spare battery type V357



Universal micrometers with interchangeable anvils

With these micrometers you are an all-rounder. The instruments have two interchangeable anvils, which gives them a lot of application possibilities. They can also be used as a height gauge, when the clamp for clamping the anvils is removed.

- Measuring range: 0-50 mm.
- Analog: graduation 0.01 mm, digital: resolution 0.001 mm.
- Accuracy: ± 0.004 mm.
- Tungsten carbide measuring face: $\varnothing 6.5$ mm.
- Delivery in a plastic case, incl. 2 tungsten carbide anvils.

Digital

- mm/inch conversion.
- ABS/INC switchable.
- On/off switch.
- Reset/preset.
- Protection: IP65.
- Power supply: 1 battery type V357.



906.190

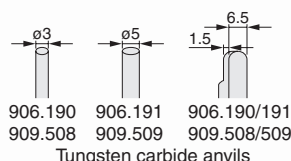

MedioTehna



909.508

Analog

Item No.	Measuring range/mm	Price HRK
906.190	0-25	
906.191	25-50	

Digital

Item No.	Measuring range/mm	Price HRK
909.508	0-25	
909.509	25-50	
Option: 836.535	Spare battery type V357	

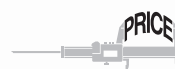

Digital micrometers IP65 with pin-shaped anvil

Digital micrometers for measuring e.g. (tube) wall thickness.

- Measuring range: 0- 50 mm.
- Resolution: 0.001 mm.
- mm/inch conversion.
- ABS/INC switchable.
- Automatic switch-off.
- Reset/preset.
- Pin-shaped anvil: \varnothing 1.8 mm.
- Tungsten carbide measuring face: \varnothing 6.5 mm.
- Protection: IP65.
- Delivery in a plastic case.
- Power supply: 1 battery type V357.



909.684

PRICE

Item No.	Measuring range/mm	Accuracy mm	Price HRK
909.684	0- 25	\pm 0.005	
909.685	25- 50	\pm 0.005	
Option:			
836.535	Spare battery type V357		

Digital micrometers with special measuring jaws

Digital micrometers with special measuring jaws for measurements in hard-to-reach places such as cut-outs in workpieces, gear pitches, etc.

- Measuring range: 0- 200 mm.
- Resolution: 0.001 mm.
- mm/inch conversion.
- ABS/INC switchable.
- Automatic switch-off.
- Reset/preset.
- Non-rotating spindle.
- Delivery in a plastic case.
- Power supply: 1 battery type V357.



909.676

PRICE

Item No.	Measuring range/mm	Accuracy mm	D mm	d \varnothing /mm	Price HRK
909.676	0- 25	\pm 0.006	R10	8	
909.677	25- 50	\pm 0.006	R10	8	
909.678	50- 75	\pm 0.007	R10	8	
909.679	75- 100	\pm 0.007	R10	8	
909.680	100- 125	\pm 0.009	R15	12	
909.681	125- 150	\pm 0.009	R15	12	
909.682	150- 175	\pm 0.010	R15	12	
909.683	175- 200	\pm 0.010	R15	12	
Option:					
836.535	Spare battery type V357				

Gear pitch micrometers

Micrometers with large, disk-shaped measuring faces for measuring e.g. gear pitches, paper and foil thickness.

- Measuring range: 0-200 mm.
- Analog: graduation 0.01 mm, digital: resolution 0.001 mm.
- Non-rotating spindle: $\varnothing 8$ mm.
- Measuring faces: stainless steel (HRC 52 - 54).
- Delivery in a plastic case.

Digital

- mm/inch conversion.
- ABS/INC switchable.
- Automatic switch-off.
- Reset/preset.
- Power supply: 1 battery type V357.



MedioTehna



Item No.	Measuring range/mm	Accuracy mm	Measuring faces \varnothing /mm	Price HRK
Analog:				
906.580	0- 25	± 0.006	20	
906.581	25- 50	± 0.006	20	
906.582	50- 75	± 0.007	20	
906.583	75-100	± 0.007	20	
906.584	100-125	± 0.009	30	
906.585	125-150	± 0.009	30	
906.586	150-175	± 0.010	30	
906.587	175-200	± 0.010	30	
Digital:				
909.777	0- 25	± 0.006	20	
909.778	25- 50	± 0.006	20	
909.779	50- 75	± 0.007	20	
909.780	75-100	± 0.007	20	
909.781	100-125	± 0.009	30	
909.782	125-150	± 0.009	30	
909.783	150-175	± 0.010	30	
909.784	175-200	± 0.010	30	
Option:				
836.535	Spare battery type V357			

Universal micrometers

With the seven interchangeable measuring inserts, which are available as an option, you are very flexible with these micrometers.

- Measuring range: 0-200 mm.
- Analog: graduation 0.01 mm, digital: resolution 0.001 mm.
- Non-rotating spindle.
- Insert shaft: $\varnothing 5$ mm.
- Delivery in a plastic case with cut-outs for inserts.

Digital

- mm/inch conversion.
- ABS/INC switchable.
- On/off switch.
- Preset (except 909.785).
- Power supply: 1 battery type V357.



MedioTehna

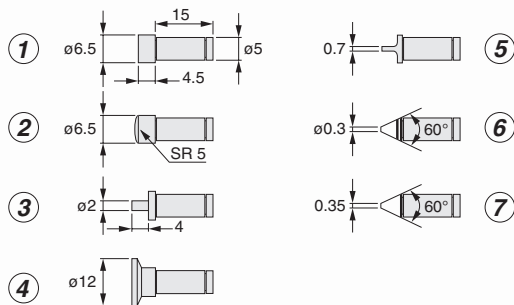

No.	Item No.	Description measuring faces	Price HRK
Measuring inserts, per pair:			
①	906.788	flat	
②	906.789	spherical	
③	906.790	small	
④	906.791	disc	
⑤	906.792	knife/flat	
⑥	906.793	point	
⑦	906.794	knife	
	906.795	Set of 7 pairs	

Item No.	Measuring range/mm	Accuracy mm	Price HRK
Analog, without measuring inserts:			
906.780	0- 25	± 0.004	
906.781	25- 50	± 0.004	
906.782	50- 75	± 0.005	
906.783	75-100	± 0.005	
906.784	100-125	± 0.008	
906.785	125-150	± 0.008	
906.786	150-175	± 0.009	
906.787	175-200	± 0.009	
Digital, without measuring inserts:			
909.785	0- 25	± 0.004	
909.786	25- 50	± 0.004	
909.787	50- 75	± 0.005	
909.788	75-100	± 0.005	
909.789	100-125	± 0.008	
909.790	125-150	± 0.008	
909.791	150-175	± 0.009	
909.792	175-200	± 0.009	
Option:			
836.535	Spare battery type V357		



Deep frame micrometers

Micrometers with a deep frame especially for measuring the thickness of e.g. sheet metal, paper and plastic sheets.

- Measuring range: 0- 50 mm.
- Analog: graduation 0.01 mm, digital: resolution 0.001 mm.
- Tungsten carbide measuring faces: $\varnothing 6.5$ mm.
- Delivery in a wooden case.

Digital

- mm/inch conversion.
- ABS/INC switchable.
- Automatic switch-off.
- Reset/preset.
- Protection: IP65.
- Power supply: 1 battery type V357.



907.068



909.694

MedioTehna



Item No.	Measuring range/mm	Accuracy mm	Throat depth/mm	Price HRK
Analog:				
907.068	0- 25	± 0.004	50	
907.069	25- 50	± 0.004	50	
907.070	0- 25	± 0.005	100	
907.071	25- 50	± 0.005	100	
907.072	0- 25	± 0.006	150	
907.073	25- 50	± 0.006	150	
Digital:				
909.694	0- 25	± 0.004	50	
909.695	25- 50	± 0.004	50	
909.696	0- 25	± 0.005	100	
909.697	25- 50	± 0.005	100	
909.698	0- 25	± 0.006	150	
909.699	25- 50	± 0.006	150	
Option:				
836.535	Spare battery type V357			

Brake disc micrometers

Micrometers especially suited for measuring the groove depth of brake discs.

- Measuring range: 7.6 - 50 mm.
- Analog: graduation 0.01 mm, digital: resolution 0.001 mm.
- Anvil with 60° point.
- Tungsten carbide measuring face: $\varnothing 6.5$ mm.
- Throat depth: 88 mm.
- Delivery in a wooden case (except 909.794: delivery in a plastic case).



907.056

Analog

Item No.	Measuring range/mm	Accuracy mm	Price HRK
907.056	7.6 - 33	± 0.004	
907.057	25 - 50	± 0.004	

Digital

- mm/inch conversion.
- ABS/INC switchable.
- Automatic switch-off.
- Reset/preset.
- Protection: IP65.
- Power supply: 1 battery type V357.

MedioTehna



909.793

Digital

Item No.	Measuring range/mm	Accuracy mm	Price HRK
909.793	7.6 - 33	± 0.004	
909.794	25 - 50	± 0.004	

Option:

836.535 Spare battery type V357

Digital micrometers IP65 with large anvils

- Measuring range: 0 - 50 mm.
- Resolution: 0.001 mm.
- mm/inch conversion.
- ABS/INC switchable.
- On/off switch.
- On/reset switch.
- Tungsten carbide measuring face: $\varnothing 6.5$ mm.
- Anvil size:
909.488: 50 x 14 mm,
909.489: 60 x 14 mm.

- Protection: IP65.
- Delivery in a wooden case.
- Power supply: 1 battery type V357.



909.488



Item No.	Measuring range/mm	Accuracy mm	Price HRK
909.488	0 - 25	± 0.004	
909.489	25 - 50	± 0.004	

Option:

836.535 Spare battery type V357

Sheet metal micrometers

Micrometers especially suited for measuring the thickness of metal sheets, e.g. sheet metal. The large dial makes the reading very easy and quick.

- Measuring range: 0- 25 mm.
- Graduation: 0.01 mm.
- Tungsten carbide measuring faces: $\varnothing 6.5$ mm.
- Throat depth: 50.
- Delivery in a wooden case.

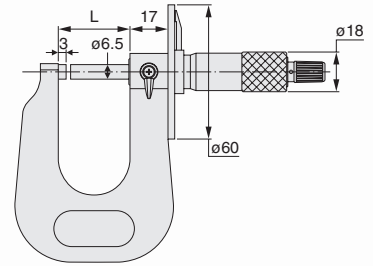

Item No.	Measuring range/mm	Accuracy mm	Measuring faces	L mm	Price HRK
907.058	0- 15	± 0.004	flat/flat	22	
907.059	0- 25	± 0.004	flat/flat	32	
907.099	0- 15	± 0.004	spherical/flat	22	
907.100	0- 25	± 0.004	spherical/flat	32	

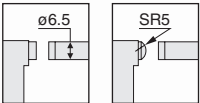

Micrometers with extra large measuring faces

Micrometers with extra large disk-shaped measuring faces for measurements of e.g. paper thickness and soft materials.

- Measuring range: 0- 100 mm.
- Graduation: 0.01 mm.
- Non-rotating spindle.
- Tungsten carbide measuring faces: $\varnothing 60$ mm.
- Delivery in a wooden case.



Item No.	Measuring range/mm	Accuracy mm	Price HRK
906.588	0- 25	± 0.008	
906.589	25- 50	± 0.008	
906.590	50- 75	± 0.010	
906.591	75- 100	± 0.010	

Gear micrometers

Micrometers with ball-tipped measuring faces for measurements of straight and tapered external gears. Several measuring inserts optionally available.

- Measuring range: 0- 175 mm.
- Analog: graduation 0.01 mm, digital: resolution 0.001 mm.
- Dimensions of anvil-tail: $\varnothing 5 \times 15$ mm.
- Tungsten carbide, ball-tipped measuring faces.
- Delivery in a plastic case with cut-outs for inserts.

Digital

- mm/inch conversion.
- ABS/INC switchable.
- Automatic switch-off.
- Reset/preset.
- Protection: IP65.
- Power supply: 1 battery type V357.



907.081

MedioTehna



909.859

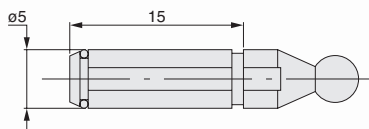

Item No.	Ball \varnothing /mm	Module	Price HRK
Measuring inserts, per pair:			
907.088	1.0	0.6-0.65	
907.089	1.5	0.9-1.0	
907.090	2.0	1.25	
907.091	2.5	1.5	
907.092	3.0	1.75	
907.093	3.5	2	
907.094	4.0	2.25	
907.095	4.5	2.5	
907.096	5.0	2.75	
907.097	6.0	3.5	
907.098	Set 907.088-907.097		

Item No.	Measuring range/mm	Accuracy mm	Price HRK
Analog, without measuring inserts:			
907.081	0- 25	± 0.004	
907.082	25- 50	± 0.004	
907.083	50- 75	± 0.005	
907.084	75-100	± 0.005	
907.085	100-125	± 0.006	
907.086	125-150	± 0.006	
907.087	150-175	± 0.007	
Digital, without measuring inserts:			
909.859	0- 25	± 0.004	
909.860	25- 50	± 0.004	
909.861	50- 75	± 0.005	
909.862	75-100	± 0.005	
909.863	100-125	± 0.006	
909.864	125-150	± 0.006	
909.865	150-175	± 0.007	
Option:			
836.535	Spare battery type V357		



Micrometers with prism-shaped anvil

Analog and digital micrometers with prism-shaped anvil for measuring the diameters of objects with an odd number of flutes such as taps, reamers and mills. The angle of the prism aperture is designed for 3-, 5- or 7-fluted workpieces.

- Measuring range: 1 - 105 mm.
- Analog: graduation 0.01 mm, digital: resolution 0.001 mm.
- Spindle: $\varnothing 6.5$ mm.
- Tungsten carbide measuring faces. The 906.160 and 909.866 have a pointed spindle for the smallest objects.
- V-groove for:
 - 3-fluted objects: 60° ,
 - 5-fluted objects: 108° ,
 - 7-fluted objects: $128^\circ 34' 17''$.
- Delivery in a plastic case, with a setting standard.

Digital

- mm/inch conversion.
- ABS/INC switchable.
- Automatic switch-off.
- Reset/preset.
- Protection: IP65.
- Power supply: 1 battery type V357.



906.161



909.866



Item No.	Measuring range/mm	Accuracy mm	Price HRK	Item No.	Price HRK
For 3-fluted objects (60°), analog:				Digital:	
906.160	1 - 15	± 0.004		909.866	
906.161	5 - 20	± 0.004		909.867	
906.162	20 - 35	± 0.005		909.868	
906.163	35 - 50	± 0.005		909.869	
906.164	50 - 65	± 0.006		909.870	
906.165	65 - 80	± 0.006		909.871	
907.060	80 - 95	± 0.007		909.872	
For 5-fluted objects (108°), analog:				Digital:	
906.166	5 - 25	± 0.004		909.873	
906.167	25 - 45	± 0.005		909.874	
906.168	45 - 65	± 0.006		909.875	
906.169	65 - 85	± 0.007		909.876	
907.061	85 - 105	± 0.008		909.877	
For 7-fluted objects ($128^\circ 34' 17''$), analog:				Digital:	
906.170	5 - 25	± 0.004		909.878	
906.171	25 - 45	± 0.005		909.879	
906.172	45 - 65	± 0.006		909.880	
906.173	65 - 85	± 0.007		909.881	
Option:					
836.535	Spare battery type V357				

MedioTehna

Setting standards

Item No.	\varnothing mm	Price HRK
909.323	5	
909.324	20	
909.325	25	
909.326	35	
909.327	45	
909.328	50	
909.329	65	
909.330	80	
909.331	85	



909.326

Micrometers with pointed measuring faces

- Measuring range: 0 - 100 mm.
- Analog: graduation 0.01 mm, digital: resolution 0.001 mm.
- Delivery in a plastic case.

Digital

- mm/inch conversion.
- ABS/INC switchable.
- Preset.
- Protection: IP65.
- Power supply: 1 battery type V357.



906.145

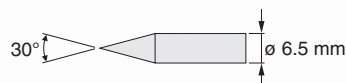

909.643

MedioTehna

Analog

Item No.	Measuring range/mm	Accuracy mm	Price HRK
906.145	0 - 25	±0.004	
906.146	25 - 50	±0.004	
906.147	50 - 75	±0.005	
906.199	75 - 100	±0.005	

Digital

Item No.	Measuring range/mm	Accuracy mm	Price HRK
909.643	0 - 25	±0.004	
909.644	25 - 50	±0.004	
909.645	50 - 75	±0.005	
909.646	75 - 100	±0.005	

Option:
836.535 Spare battery type V357

Micrometers with one pointed measuring face

- Measuring range: 0 - 50 mm.
- Graduation: 0.01 mm.
- Delivery in a plastic case.



906.151

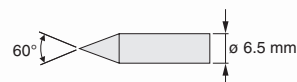

Item No.	Measuring range/mm	Accuracy mm	Price HRK
906.151	0 - 25	±0.004	
906.153	25 - 50	±0.004	

Blade micrometers

For measuring grooves, keyways and other hard-to-reach places.

- Measuring range: 0- 175 mm.
- Analog: graduation 0.01 mm, digital: resolution 0.001 mm.
- Non-rotating spindle.
- Blade width: 0.75 mm, blade length: 6 mm, blade width: 6 mm.
- Delivery in a plastic case.

Digital

- mm/inch conversion.
- ABS/INC switchable.
- Reset/preset.
- Hold function.
- Power supply: 1 battery type V357.



906.141

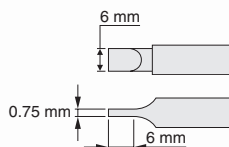

MedioTehna



909.882

Analog

Item No.	Measuring range/mm	Accuracy mm	Price HRK
906.141	0- 25	±0.004	
906.142	25- 50	±0.004	
906.143	50- 75	±0.005	
906.144	75- 100	±0.005	
906.222	100- 125	±0.006	
906.223	125- 150	±0.006	
906.224	150- 175	±0.007	

Digital

Item No.	Measuring range/mm	Accuracy mm	Price HRK
909.882	0- 25	±0.004	
909.883	25- 50	±0.004	
909.884	50- 75	±0.005	
909.885	75- 100	±0.005	
909.886	100- 125	±0.006	
909.887	125- 150	±0.006	
909.888	150- 175	±0.007	

Option:

836.535 Spare battery type V357



Screw thread micrometers

- Measuring range: 0 - 200 mm.
- Analog: graduation 0.01 mm, digital: resolution 0.001 mm.
- Insert shaft: $\varnothing 5$ mm.
- DIN 863 T3.
- Delivery incl. adjustment tools.
- From measuring range 25 - 50 mm including setting gauge 60° .
- Matt chrome-plated thimble.
- Delivery in a plastic case with cut-outs for inserts.

Digital

- mm/inch conversion.
- ABS/INC switchable.
- On/off switch.
- Reset/preset.
- Protection: IP65.
- Power supply: 1 battery type V357.

Analog

- Non-rotating spindle.



MedioTehna



Analog, without measuring inserts

Item No.	Measuring range/mm	Accuracy mm	Price HRK
906.750	0 - 25	± 0.004	
906.751	25 - 50	± 0.004	
906.752	50 - 75	± 0.005	
906.753	75 - 100	± 0.005	
906.754	100 - 125	± 0.006	
906.755	125 - 150	± 0.006	
906.756	150 - 175	± 0.007	
906.757	175 - 200	± 0.007	

Digital, without measuring inserts

Item No.	Measuring range/mm	Accuracy mm	Price HRK
909.889	0 - 25	± 0.004	
909.890	25 - 50	± 0.004	
909.891	50 - 75	± 0.005	
909.892	75 - 100	± 0.005	
909.893	100 - 125	± 0.006	
909.894	125 - 150	± 0.006	
909.895	150 - 175	± 0.007	
909.896	175 - 200	± 0.007	

Option:

836.535 Spare battery type V357

Screw thread micrometers (continued)

Measuring inserts for screw thread micrometers with clamping shaft $\varnothing 5$ mm.



906.725

Item No.	Threads per inch	Price HRK
Measuring inserts for Whitworth threads, 55° flank angle, per pair:		
906.730	60 -48	
906.731	48 -40	
906.732	40 -32	
906.733	32 -24	
906.734	24 -18	
906.735	18 -14	
906.736	14 -10	
906.737	10 - 7.0	
906.738	7.0- 4.5	
906.739	4.5- 3.5	
906.740	Set 60-3.5	

Item No.	Pitch/mm	Price HRK
Measuring inserts for metric threads, 60° flank angle, per pair:		
906.720	0.4 -0.5	
906.721	0.6 -0.9	
906.722	1.0 -1.75	
906.723	2.0 -3.0	
906.724	3.5 -5.0	
906.725	5.5 -7.0	
906.726	Set 0.4-7.0	

Item No.	Threads per inch	Price HRK
Measuring inserts for UN, UNC and UNF threads, 60° flank angle, per pair:		
906.741	64 -48	
906.742	44 -28	
906.743	24 -14	
906.744	13 - 9	
906.745	8 - 5	
906.746	4.5- 3.5	
906.747	Set 64-3.5	



909.305

MedioTehna

Item No.	Length/mm	Price HRK
Hardened steel setting standards for threads with 60° flank angle:		
909.304	25	
909.305	50	
909.306	75	
909.307	100	
909.308	125	
909.309	150	
909.310	175	
909.311	200	

Item No.	Length/mm	Price HRK
Hardened steel setting standards for threads with 55° flank angle:		
909.312	25	
909.313	50	
909.314	75	
909.315	100	
909.316	125	
909.317	150	
909.318	175	
909.319	200	

Thread measuring wires

For measuring external threads using the three-wire method. The flank diameter can be determined according to the measured diameter, using tables.

- For micrometers with measuring faces $\phi 6.35$, $\phi 6.5$ or $\phi 8$ mm. (Also available for measuring faces $\phi 6.8$ and $\phi 7.5$ mm.)
- Very high measuring accuracy: ± 0.001 mm.
- In pairs or in a set.
- The wire holders are held in position on the anvil and spindle by a spring clamp.
- The wires are mounted on the holder in such a way that they position themselves on the thread.



MedioTehna

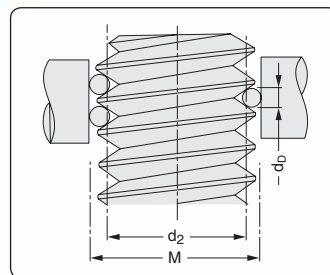

Thread measuring wires for micrometers with measuring faces $\phi 6.35$, $\phi 6.5$ or $\phi 8$ mm

$\phi 6.35$ mm		$\phi 6.5$ mm		$\phi 8$ mm		Wire diameter d_w /mm	Metric, pitch in mm	Whitworth, threads per inch	UN/UNC/UNF, threads per inch
Item No.	Price HRK	Item No.	Price HRK	Item No.	Price HRK				
833.442		779.161		836.689		0.17	0.25; 0.3	–	–
833.443		781.651		836.690		0.195	–	–	80
833.444		779.162		836.691		0.22	0.35	–	72
833.445		779.163		835.844		0.25	0.4	–	64
833.446		779.164		834.499		0.29	0.45; 0.5	–	56
833.447		779.165		834.498		0.335	0.6	40	48; 44
833.448		781.652		837.848		0.390	–	–	40
833.449		779.166		833.872		0.455	0.7-0.8	–	36
833.450		779.167		834.585		0.53	–	32; 28	32; 28
833.451		779.168		834.480		0.62	1	26; 24	24
833.452		779.169		834.586		0.725	1.25	22; 20; 19	20
833.453		779.170		834.290		0.895	1.5	18; 16	18; 16
833.454		779.171		834.502		1.10	1.75	14	14; 13
833.455		779.172		834.291		1.35	2	12; 11	12; 11
833.456		779.173		833.871		1.65	2.5	10; 9	10; 9
833.457		779.174		834.292		2.05	3.0; 3.5	8; 7	8; 7
833.458		779.175		834.416		2.55	4.0; 4.5	6	6
833.459		779.176		834.483		3.20	5.0; 5.5	5; 4.5	5; 4.5
837.501		837.642		834.509		4.00	6.0	4; 3.5	4
834.580		779.160		834.581		Set with wire diameters 0.17 to 3.20 mm			

Hub micrometers

Micrometers with a shallow bracket for measuring the thickness of bearing bushes, bore shoulders and other hard-to-reach places.

- Measuring range: 0- 100 mm.
- Graduation: 0.01 mm.
- Tungsten carbide measuring faces: $\varnothing 6.5$ mm.
- Varnished frame.
- Throat depth: 10.2 mm.
- Throat height: 21.2 mm (907.133: 18.7 mm).



907.133

Item No.	Measuring range/mm	Accuracy mm	Price HRK
907.133	0- 25	± 0.004	
907.134	25- 50	± 0.004	
907.135	50- 75	± 0.004	
907.136	75- 100	± 0.005	

MedioTehna



Can seam micrometer

Micrometer especially for measuring the depth and thickness of e.g. the seams of steel cans.

- Measuring range: 0- 13 mm.
- Graduation: 0.01 mm.
- Accuracy: ± 0.004 mm.
- Tungsten carbide measuring faces: $\varnothing 5$ mm.



Item No.	Measuring range/mm	Price HRK
907.175	0- 13	

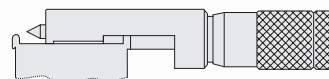

Wire and ball micrometer

- Measuring range: 0- 10 mm.
- Graduation: 0.01 mm.
- Accuracy: ± 0.004 mm.
- Tungsten carbide measuring faces: $\varnothing 6.5$ mm.



Item No.	Measuring range/mm	Price HRK
906.175	0- 10	



Setting gauges

Cylindrical gauges for micrometers with flat parallel measuring faces.

- Measuring faces $L < 100$ mm: $\varnothing 7$ mm, flat,
 $L < 300$ mm: $\varnothing 8$ mm, flat,
 $L \geq 300$ mm: $\varnothing 8$ mm, spherical.
- With plastic insulating grip.
- Larger sizes available on request.



Item No.	Length mm	Accuracy μm	Price HRK
907.464	25	± 2	
907.465	50	± 2	
907.466	75	± 2.5	
907.467	100	± 2.5	
907.468	125	± 3	
907.469	150	± 3	
907.470	175	± 3.5	
907.471	200	± 4	
907.472	225	± 4	
907.473	250	± 4	
907.474	275	± 4.5	
907.475	300	± 4.5	
907.476	325	± 5	
907.477	350	± 5	
907.478	375	± 5.5	
907.479	400	± 5.5	
907.480	425	± 6	
907.481	450	± 6	
907.482	475	± 6.5	
907.483	500	± 6.5	
907.484	525	± 7	
907.485	575	± 7.5	
907.486	625	± 7.5	
907.487	675	± 8	
907.488	725	± 8.5	
907.489	775	± 9.5	
907.490	825	± 10	
907.491	875	± 10.5	
907.492	925	± 11	
907.493	975	± 11.5	
907.494	1050	± 12	
907.495	1150	± 13	
907.496	1250	± 14	
907.497	1350	± 15	
907.498	1450	± 16	
909.529 ¹	1550	± 17	
909.530 ¹	1650	± 18	
909.531 ¹	1750	± 19	
909.532 ¹	1850	± 20	
909.533 ¹	1950	± 21	

¹ Delivery ex Groningen, Netherlands.

Setting standards

Cylindrical setting standards for micrometers with prism-shaped anvil.



Item No.	Diameter/mm	Price HRK
909.323	5	
909.324	20	
909.325	25	
909.326	35	
909.327	45	
909.328	50	
909.329	65	
909.330	80	
909.331	85	

Setting standards

Hardened steel setting standards for threads with 55° or 60° flank angle.



Item No.	Length/mm	Price HRK
For threads with 60° flank angle:		
909.304	25	
909.305	50	
909.306	75	
909.307	100	
909.308	125	
909.309	150	
909.310	175	
909.311	200	
For threads with 55° flank angle:		
909.312	25	
909.313	50	
909.314	75	
909.315	100	
909.316	125	
909.317	150	
909.318	175	
909.319	200	

Micrometer stand

Rigid table stand for micrometers.

- Inclination adjustable.
- Weight: 1.1 kg.



Item No.	Clamping range/mm	Price
906.212	0 - 18	

Micrometer stand

Cast steel stand for micrometers.

- Fixed inclination: 45°.
- Weight: 0.7 kg.



Item No.	Clamping range/mm	Price
908.983	4 - 12	

Foldable micrometer stand

Portable stand with a folded structure for micrometers.

- Inclination adjustable.
- Weight: 1 kg.



Item No.	Clamping range/mm	Price
907.152	7 - 14	

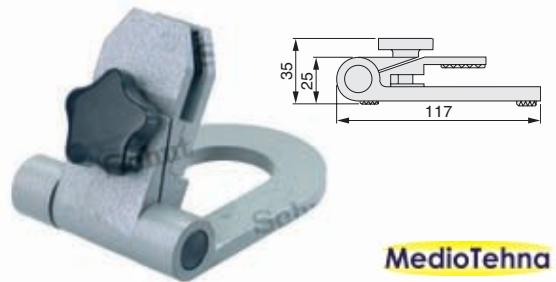

MedioTehna

Ball attachments

These ball attachments can be clamped on any anvil and spindle with a diameter of 6.5 or 8 mm.

- Ball: $\varnothing 5$ mm.



Item No.	Description	Price HRK
907.150	Ball attachment, $\varnothing 6.5$ mm	
907.166	Ball attachment, $\varnothing 8$ mm	

Measuring force indicators

Within the range of 5 to 12 N these measuring force indicators can show the measuring force of micrometers.



Item No.	For micrometers	Price HRK
907.151	0 - 25 mm	
908.947	25 - 50 mm	
908.948	50 - 75 mm	
908.949	75 - 100 mm	

Probe set for micrometers

These attachments can be clamped on any anvil and spindle with a diameter of 6.5 mm. The set consists of a point-shaped, knife-edged, blade-shaped, disk-shaped, ball-shaped probe and one with a small and one with a very small measuring face.

- Delivery in a plastic case.



Item No.	Description	Price HRK
909.118	Probe set for micrometers	

MedioTehna



Micrometer inspection sets

For the inspection of micrometers according DIN 863. Suitable for micrometers with a measuring range up to 25 mm.

- Nominal sizes (mm):
2.5-5.1-7.7-10.3-12.9-15.0-17.6-20.2-22.8-25.0.
- Including plan parallel optical flat $\varnothing 30 \times 12$ mm.
- Delivery in a wooden case with a manufacturer measuring report.



Item No.	Material	Grade	Price HRK
909.346	steel	1	
909.345	steel	0	
909.162	ceramic	1	
909.340	ceramic	0	



909.340

Thread and tolerance tables

Thread table

Table with all standard international thread indications: metric, BSW, Gas, BSF, Pg, BA, UNC, UNF, UNEF, EG-M and EG-MF.

Tolerance table

Table comprising all tolerances and fits according ISO 286-2, up to 500 mm (table with over 6400 pairs of tolerance values for internal and external measurements).

Conversion table mm/inch

For converting from mm to inch and from inch to mm.

Item No.	Description	Price HRK
835.162	Thread table	
835.163	Tolerance table	
835.164	Conversion table mm/inch	



835.162

835.163

835.164

Digital depth micrometers IP65

Digital depth micrometers with interchangeable, spherical rods or flat rods. With the flat rods mainly flat and spherical surfaces can be measured very accurately. The spherical rods are especially suitable for beveled and hollow surfaces. The high accuracy of the rods makes resetting after exchanging the rods unnecessary. Two models with different base lengths available.

- Measuring range: 0-300 mm.
- Resolution: 0.001 mm.
- mm/inch conversion.
- ABS/INC switchable.
- Automatic switch-off.
- Preset.
- Measuring rods: $\varnothing 4.5$ mm.
- Locking screw.
- Protection: IP65.
- Power supply: 1 battery type V357.



Model with spherical rods especially for hollow and beveled surfaces

Item No.	Price HRK	Item No.	Price HRK	Measuring range/mm	Accuracy mm	Number of rods
Base 63 mm:		Base 101.5 mm:				
909.753		909.759		0- 25	± 0.005	1
909.754		909.760		0- 50	± 0.005	2
909.755		909.761		0-100	± 0.006	4
909.756		909.762		0-150	± 0.007	6
909.757		909.763		0-200	± 0.008	8
909.758		909.764		0-300	± 0.009	12

Model with flat rods especially for flat and spherical surfaces

Item No.	Price HRK	Item No.	Price HRK	Measuring range/mm	Accuracy mm	Number of rods
Base 63 mm:		Base 101.5 mm:				
909.765		909.771		0- 25	± 0.005	1
909.766		909.772		0- 50	± 0.005	2
909.767		909.773		0-100	± 0.006	4
909.768		909.774		0-150	± 0.007	6
909.769		909.775		0-200	± 0.008	8
909.770		909.776		0-300	± 0.009	12

Option

Item No.	Description	Price HRK
836.535	Spare battery type V357	

MedioTehna

Depth micrometers

Depth micrometers with interchangeable, spherical or flat rods. With the flat rods mainly flat and spherical surfaces can be measured very accurately. The spherical rods are especially suitable for beveled and hollow surfaces. The high accuracy of the rods makes recalibration after exchanging the rods unnecessary. Two models with different base lengths available.

- Measuring range: 0-300 mm.
- Graduation: 0.01 mm.
- Measuring rods: $\varnothing 4.5$ mm.
- Locking screw.

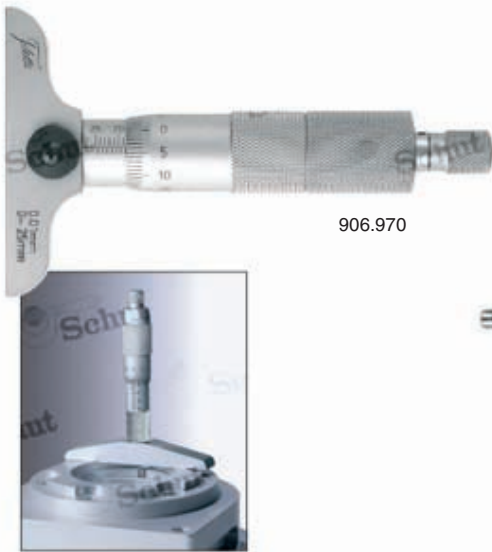

906.970

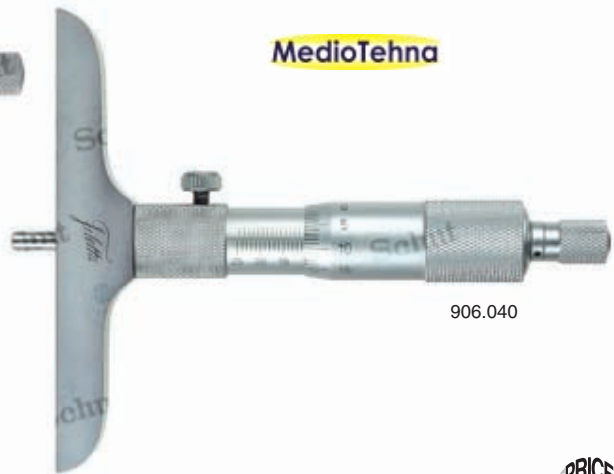

906.040



Model with spherical rods especially for hollow and beveled surfaces

Item No.	Price HRK	Item No.	Price HRK	Measuring range/mm	Accuracy mm	Number of rods
Base 63 mm:		Base 101.5 mm:				
906.964		906.040		0- 25	± 0.005	1
906.965		906.039		0- 50	± 0.005	2
906.966		906.041		0-100	± 0.006	4
906.967		906.042		0-150	± 0.007	6
906.968		906.043		0-200	± 0.008	8
906.969		906.044		0-300	± 0.009	12

Model with flat rods especially for flat and spherical surfaces

Item No.	Price HRK	Item No.	Price HRK	Measuring range/mm	Accuracy mm	Number of rods
Base 63 mm:		Base 101.5 mm:				
906.970		906.976		0- 25	± 0.005	1
906.971		906.977		0- 50	± 0.005	2
906.972		906.978		0-100	± 0.006	4
906.973		906.979		0-150	± 0.007	6
906.974		906.980		0-200	± 0.008	8
906.975		906.981		0-300	± 0.009	12

Micrometer head with counter

Micrometer head with an easy read-out at 0.01 mm by means of the counter mechanism.

- Measuring range: 0-25 mm.
- Resolution: 0.01 mm.
- Accuracy: ± 0.003 mm.
- Numerical counter adjustable.
- Rotating spindle: $\phi 6.5$ mm.
- Tungsten carbide measuring face.
- Delivery with adjustment tool.



MedioTehna

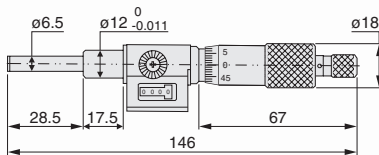

Item No.	Measuring range/mm	Spindle ϕ /mm	Price HRK
906.543	0-25	6.5	

Micrometer heads

- Measuring range: 0-25 mm.
- Graduation: 0.01 mm or vernier 0.002 mm.



906.072

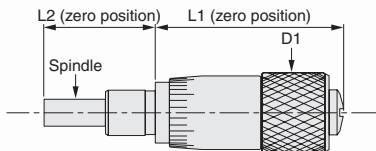

906.074



906.070

Item No.	Measuring range/mm	Graduation mm	Accuracy mm	Spindle ϕ /mm	Dimensions/mm clamping	D1	L1	L2	Price HRK
Without friction thimble, steel measuring face:									
906.070	0- 6.5	0.01	± 0.005	3.5 (flat)	$\phi 6 \times 6$	$\phi 10$	23	14	
906.074	0- 6.5	0.01	± 0.005	3.5 (spherical)	$\phi 6 \times 6$	$\phi 10$	23	14	
906.071	0- 13	0.01	± 0.004	5.0 (flat)	$\phi 9.5 \times 9.5$	$\phi 14$	33	26	
Friction thimble with spring click in measuring thimble, tungsten carbide measuring face:									
906.072	0-25	0.01	± 0.003	6.5 (flat)	$\phi 12 \times 17$	$\phi 19$	65	46	
906.073	0-25	0.002	± 0.003	6.5 (flat)	$\phi 12 \times 17$	$\phi 19$	65	46	

Digital micrometer heads

Several digital micrometer heads with different possibilities.

- Measuring range: 0-50 mm.
- Resolution: 0.001 mm.
- Accuracy: ± 0.003 mm (909.900/901: ± 0.005 mm).
- mm/inch conversion.
- ABS/INC switchable.
- On/off switch.
- Automatic switch-off.
- Memory absolute measuring value.
- Preset for ABS measurement.
- Friction thimble.
- Power supply: 1 battery type V357.

MedioTehna



Item No.	Measuring range/mm	Dimensions/mm		Dimensions/mm		Description	Price
		spindle	clamping	L1	L2	measuring faces	HRK
With IP65 protection:							
909.897	0-25	$\phi 6.5$	$\phi 12 \times 17.5$	115	46	flat, tungsten carbide measuring face	
909.898	0-25	$\phi 6.5$	$\phi 12 \times 17.5$	115	46	spherical	
909.899	0-25	$\phi 6.5$	$\phi 12 \times 17.5$	116	56	flat, non-rotating tip	
909.900	0-50	$\phi 7.5$	$\phi 12 \times 35.5$	140	89	flat, tungsten carbide measuring face	
909.901	0-50	$\phi 7.5$	$\phi 12 \times 35.5$	140	89	spherical	
With non-rotating spindle:							
909.902	0-25	$\phi 7.5$	$\phi 12 \times 10$	124	39	flat, tungsten carbide measuring face	
909.903	0-25	$\phi 7.5$	$\phi 12 \times 10$	123	39	interchangeable measuring inserts	
Option:							
836.535	Spare battery type V357						

Interchangeable measuring inserts for 909.903

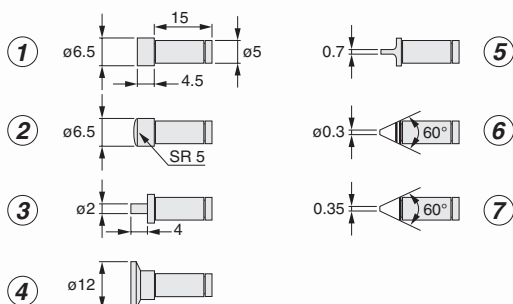

No.	Item No.	Description	Price
		measuring faces	HRK
Measuring inserts, per pair:			
①	906.788	flat	
②	906.789	spherical	
③	906.790	small	
④	906.791	disc	
⑤	906.792	knife/flat	
⑥	906.793	point	
⑦	906.794	knife	
	906.795	Set of 7 pairs	

Internal micrometers / Internal & external measuring instruments

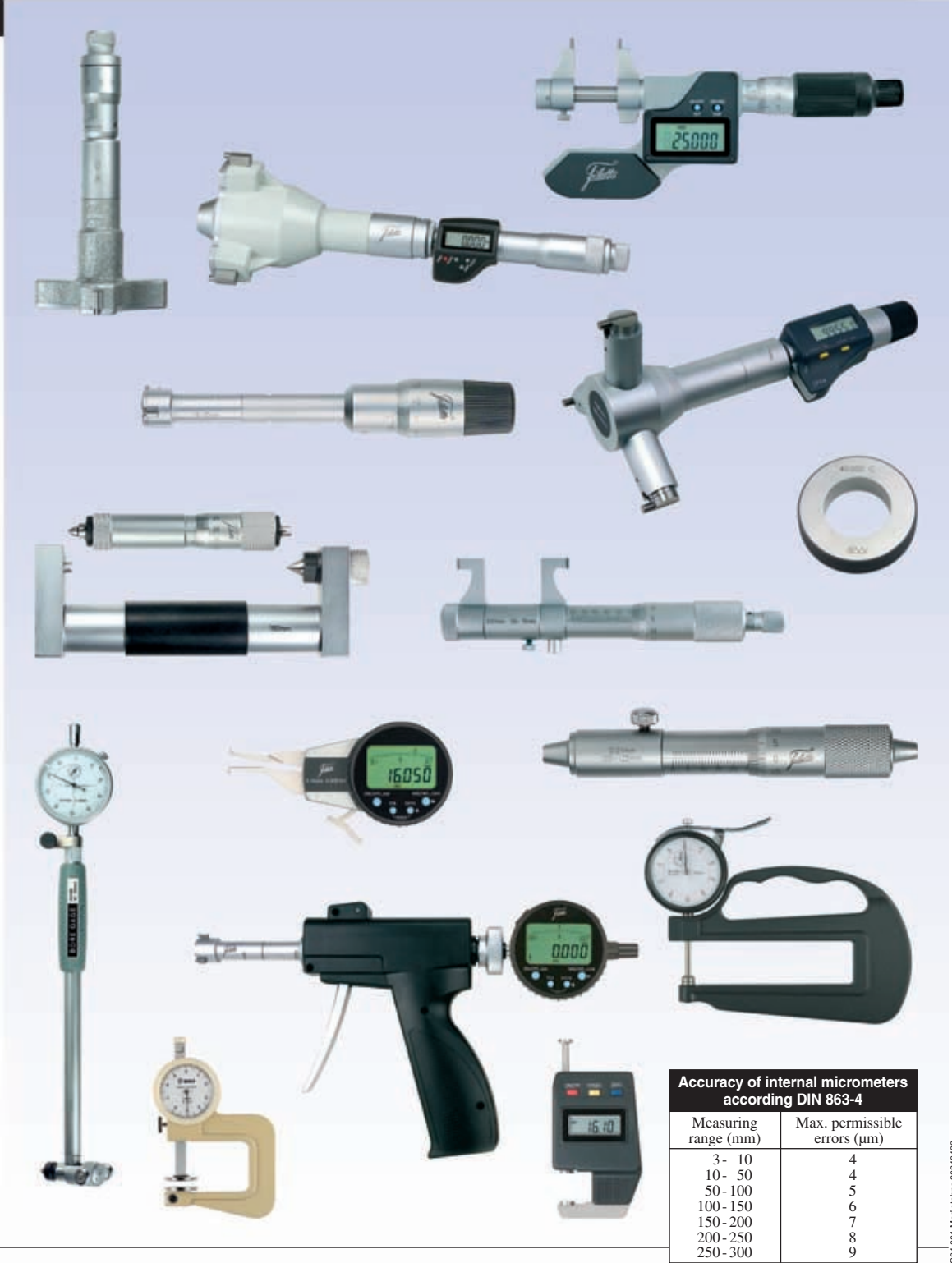

Accuracy of internal micrometers according DIN 863-4

Measuring range (mm)	Max. permissible errors (µm)
3 - 10	4
10 - 50	4
50 - 100	5
100 - 150	6
150 - 200	7
200 - 250	8
250 - 300	9

Three-point internal micrometers

Three-point internal micrometers for quick and accurate measurement of internal dimensions, within a large measuring range.

- Measuring range: \varnothing 3.5 - 300 mm.
- Graduation: 0.001 mm (\varnothing 3.5 - 12 mm),
0.005 mm (\varnothing 12 - 300 mm).
- Self-centering.
- Tungsten carbide measuring faces.
- Sets are delivered incl. setting rings and extension (836.730 without extension).
- Setting rings are conform to factory standard.
- Delivery in a wooden case.



836.708



836.718



836.745

MedioTehna



Measuring head
(measuring range)
 \varnothing 3.5 - 50 mm



\varnothing 50 - 100 mm



\varnothing 100 - 300 mm



\varnothing 100 - 300 mm

17.5 mm



Three-point internal micrometers (continued)

Item No.	Measuring range/mm	Accuracy mm	Length L/mm	Length A/mm	Price HRK
836.700	∅ 3.5- 4	±0.005	19	1.5	
836.701	∅ 4.0- 4.5	±0.005	19	1.5	
836.702	∅ 4.5- 5.5	±0.005	19	1.5	
836.703	∅ 5.5- 6.5	±0.005	19	1.5	
836.704	∅ 6 - 8	±0.005	52	1.5	
836.705	∅ 8 - 10	±0.005	52	1.5	
836.706	∅ 10 - 12	±0.005	52	1.5	
836.707	∅ 12 - 16	±0.005	71	1.5	
836.708	∅ 16 - 20	±0.005	71	1.5	
836.709	∅ 20 - 25	±0.005	82	1.5	
836.710	∅ 25 - 30	±0.005	82	1.5	
836.711	∅ 30 - 35	±0.005	84	1.5	
836.712	∅ 35 - 40	±0.005	84	1.5	
836.713	∅ 40 - 50	±0.006	100	1.5	
836.714	∅ 50 - 60	±0.006	100	1.5	
836.715	∅ 60 - 70	±0.006	100	1.5	
836.716	∅ 70 - 80	±0.006	100	1.5	
836.717	∅ 80 - 90	±0.006	100	1.5	
836.718	∅ 90 - 100	±0.006	100	1.5	
836.719	∅ 100 - 125	±0.008	110	17.5	
836.720	∅ 125 - 150	±0.008	110	17.5	
836.721	∅ 150 - 175	±0.008	110	17.5	
836.722	∅ 175 - 200	±0.008	110	17.5	
836.723	∅ 200 - 225	±0.012	110	17.5	
836.724	∅ 225 - 250	±0.012	110	17.5	
836.725	∅ 250 - 275	±0.012	110	17.5	
836.726	∅ 275 - 300	±0.012	110	17.5	

MedioTehna

Extensions

Item No.	Extension mm	For measuring range/mm	Price HRK
836.780	100	∅ 6- 12	
836.782	150	∅ 12- 20	
836.784	150	∅ 20- 40	
836.786	150	∅ 40- 100	



836.784



Sets

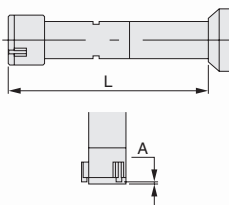

Item No.	Measuring range/mm	Setting rings mm	Extension mm	Number of instruments	Price HRK
836.730*	∅ 3.5- 6.5	∅ 4, 5.5	-	4	
836.735	∅ 6 - 12	∅ 8, 10	100	3	
836.740	∅ 12 - 20	∅ 16	150	2	
836.745	∅ 20 - 40	∅ 25, 35	150	4	
836.750	∅ 40 - 100	∅ 50, 70, 90	150	6	

* Without extension.

Three-point internal micrometers

Three-point internal micrometers, with a manufacturer measuring report, for accurately measuring (blind) bores.

- Measuring range: $\phi 6 - 300$ mm.
- Self-centering.
- Tungsten carbide measuring faces (measuring range $\phi 6 - 12$ mm: hardened steel).
- Separate instruments within measuring range $\phi 6 - 100$ mm and the sets are delivered incl. setting ring(s) and extension.
- Setting rings are conform to factory standard.
- To $\phi 100$ mm: implementation for blind bores. From $\phi 100$ mm: implementation for through holes or blind bores.
- Delivery in an aluminum case ($\phi 6 - 40$ mm) or an aluminum carrying case ($\phi 40 - 300$ mm and sets) with a manufacturer measuring report.

Analog

- Graduation: 0.001 mm ($\phi 6 - 12$ mm), 0.005 mm ($\phi 12 - 300$ mm).

Digital

- Resolution: 0.001 mm.
- mm/inch conversion.
- On/off switch.
- Reset.
- Preset.
- Hold function.
- Protection: IP54.
- Power supply: 1 battery type V357.



909.811



909.832



Measuring head (measuring range) $\phi 6 - 50$ mm



$\phi 50 - 100$ mm



$\phi 100 - 175$ mm



$\phi 175 - 300$ mm



For blind bores



For through holes

20 mm

Three-point internal micrometers (continued)

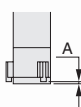
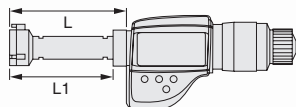
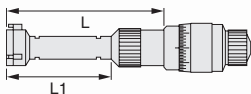

MedioTehna

PRICE



Item No.	Price HRK	Item No.	Price HRK	Measuring range/mm	Accuracy mm	L/mm	Length L/mm	A/mm
Analog (blind bores):		Digital (blind bores):				Analog:	Digital:	
						L1 L	L1 L	
909.807		909.828		∅ 6- 8	±0.004	27 -	43 -	1
909.808		909.829		∅ 8- 10	±0.004	50 -	43 -	1
909.809		909.830		∅ 10- 12	±0.004	50 -	43 -	1
909.810		909.831		∅ 12- 16	±0.004	50 -	45 -	0.4
909.811		909.832		∅ 16- 20	±0.004	50 -	45 -	0.4
909.812		909.833		∅ 20- 25	±0.004	- 80	53 -	0.4
909.813		909.834		∅ 25- 30	±0.004	- 80	53 -	0.4
909.814		909.835		∅ 30- 40	±0.004	- 90	- 80	0.4
909.815		909.836		∅ 40- 50	±0.005	- 90	- 80	0.4
909.816		909.837		∅ 50- 63	±0.005	- 100	- 80	0.5
909.817		909.838		∅ 62- 75	±0.005	- 100	- 80	0.5
909.818		909.839		∅ 75- 88	±0.005	- 100	- 80	0.5
909.819		909.840		∅ 87-100	±0.005	- 100	- 80	0.5
910.150		910.158		∅ 100-125	±0.008	- 140	- 140	0.5
910.151		910.159		∅ 125-150	±0.008	- 140	- 140	0.5
910.152		910.160		∅ 150-175	±0.008	- 140	- 140	0.5
910.153		910.161		∅ 175-200	±0.008	- 140	- 140	0.5
910.154		910.162		∅ 200-225	±0.008	- 140	- 140	0.5
910.155		910.163		∅ 225-250	±0.008	- 140	- 140	0.5
910.156		910.164		∅ 250-275	±0.008	- 140	- 140	0.5
910.157		910.165		∅ 275-300	±0.008	- 140	- 140	0.5
Analog (through holes):		Digital (through holes):				Analog:	Digital:	
						L1 L	L1 L	
909.820		909.841		∅ 100-125	±0.008	- 140	- 140	20
909.821		909.842		∅ 125-150	±0.008	- 140	- 140	20
909.822		909.843		∅ 150-175	±0.008	- 140	- 140	20
909.823		909.844		∅ 175-200	±0.008	- 140	- 140	20
909.824		909.845		∅ 200-225	±0.008	- 140	- 140	20
909.825		909.846		∅ 225-250	±0.008	- 140	- 140	20
909.826		909.847		∅ 250-275	±0.008	- 140	- 140	20
909.827		909.848		∅ 275-300	±0.008	- 140	- 140	20

Sets

Item No.	Price HRK	Item No.	Price HRK	Measuring range/mm	Setting rings ∅/mm	Extension mm	Number of instruments
Analog:		Digital:					
909.849		909.853		∅ 6- 12	8, 10	50	3
909.850		909.854		∅ 12- 20	16	100	2
909.851		909.855		∅ 20- 50	25, 40	150	4
909.852		909.856		∅ 50- 100	62, 87	150	4

Options

Item No.	Description	Price HRK
836.535	Spare battery type V357	
For meas. range ∅ 100 - 300 mm:		
909.857	Extension with length 150 mm	

909.850



Three-point internal micrometers

Three-point internal micrometers for accurately measuring (blind) bores.

- Measuring range: $\varnothing 6 - 300$ mm.
- Graduation: 0.001 mm ($\varnothing 6 - 12$ mm),
0.005 mm ($\varnothing 12 - 300$ mm).
- Self-centering.
- Tungsten carbide measuring faces.
- Interchangeable measuring bolts from measuring range $\varnothing 150 - 175$ mm.
- Delivery in an aluminum case ($\varnothing 6 - 40$ mm) or an aluminum carrying case ($\varnothing 40 - 300$ mm and sets) with extension 150 mm ($\varnothing 6 - 12$ mm: 100 mm).
- Separate instruments within measuring range $\varnothing 6 - 100$ mm and the sets are delivered incl. setting ring(s).
- Setting rings are conform to factory standard.

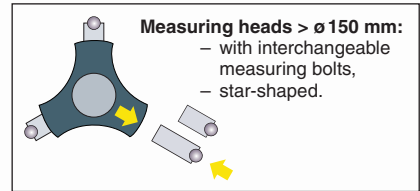

MedioTehna



908.654



908.662



Measuring head
(measuring range)
 $\varnothing 6 - 50$ mm



$\varnothing 50 - 100$ mm



$\varnothing 100 - 300$ mm



For blind bores



Three-point internal micrometers (continued)



MedioTehna

908.672



Per piece

Item No.	Measuring range/mm	Setting ring ϕ /mm	Accuracy mm	Length L/mm	Length A/mm	Price HRK
908.650	ϕ 6- 8	6	± 0.004	54.5	0.7	
908.651	ϕ 8- 10	8	± 0.004	54.5	0.7	
908.652	ϕ 10- 12	10	± 0.004	54.5	0.7	
908.653	ϕ 12- 16	16	± 0.004	80	0.7	
908.654	ϕ 16- 20	16	± 0.004	80	0.7	
908.655	ϕ 20- 25	25	± 0.004	90	0.7	
908.656	ϕ 25- 30	25	± 0.004	90	0.7	
908.657	ϕ 30- 40	40	± 0.004	97	0.7	
908.658	ϕ 40- 50	40	± 0.005	97	0.7	
908.659	ϕ 50- 63	62	± 0.005	114	0.7	
908.660	ϕ 62- 75	62	± 0.005	114	0.7	
908.661	ϕ 75- 88	87	± 0.005	114	0.7	
908.662	ϕ 87-100	87	± 0.005	114	0.7	
908.663	ϕ 100-125	-	± 0.005	145	0.7	
908.664	ϕ 125-150	-	± 0.005	145	0.7	
908.665	ϕ 150-175	-	± 0.005	145	0.7	
908.666	ϕ 175-200	-	± 0.005	145	0.7	
908.667	ϕ 200-225	-	± 0.007	145	0.7	
908.668	ϕ 225-250	-	± 0.007	145	0.7	
908.669	ϕ 250-275	-	± 0.007	145	0.7	
908.670	ϕ 275-300	-	± 0.007	145	0.7	

Sets

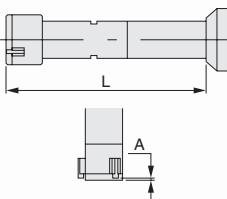

Item No.	Measuring range/mm	Setting rings ϕ /mm	Extension mm	Number of instruments	Price HRK
908.671	ϕ 6- 12	6, 8, 10	100	3	
908.672	ϕ 12- 20	16	150	2	
908.673	ϕ 20- 50	25, 40	150	4	
908.674	ϕ 50-100	62, 87	150	4	

Digital three-point internal micrometers IP65

Digital three-point internal micrometers with a resolution of 0.001 mm for accurately measuring (blind) bores. These micrometers have several functions, and combined with the accurate read-out this results in a favourable price-performance ratio.

- Measuring range: \varnothing 6-300 mm.
- Resolution: 0.001 mm.
- mm/inch conversion.
- ABS/INC switchable.
- On/off switch.
- Automatic switch-off.
- Reset/preset.
- Self-centering.
- Tungsten carbide measuring faces.
- Complete measuring range without changing the measuring bolts.
- Protection: IP65.
- Delivery in an aluminum case (\varnothing 6-40 mm) or an aluminum carrying case (\varnothing 40-300 mm and sets) with extension 150 mm (\varnothing 6-12 mm: 100 mm).
- Separate instruments within measuring range \varnothing 6-100 mm and the sets are delivered incl. setting ring(s) (conforms to factory standard).
- Power supply: 1 battery type V357.



MedioTehna



Measuring head
(measuring range)
 \varnothing 6-50 mm



\varnothing 50-100 mm



\varnothing 100-300 mm



For blind bores



Digital three-point internal micrometers IP65 (continued)



910.134

MedioTehna

PRICE

Per piece

Item No.	Measuring range/mm	Setting ring ϕ /mm	Accuracy mm	Length L/mm	Length A/mm	Price HRK
910.113	ϕ 6- 8	6	± 0.004	54.5	1.5	
910.114	ϕ 8- 10	8	± 0.004	54.5	1.5	
910.115	ϕ 10- 12	10	± 0.004	54.5	1.5	
910.116	ϕ 12- 16	16	± 0.004	80	0.7	
910.117	ϕ 16- 20	16	± 0.004	80	0.7	
910.118	ϕ 20- 25	25	± 0.004	90	0.7	
910.119	ϕ 25- 30	25	± 0.004	90	0.7	
910.120	ϕ 30- 40	40	± 0.004	97	0.7	
910.121	ϕ 40- 50	40	± 0.005	97	0.7	
910.122	ϕ 50- 63	62	± 0.005	114	0.7	
910.123	ϕ 62- 75	62	± 0.005	114	0.7	
910.124	ϕ 75- 88	87	± 0.005	114	0.7	
910.125	ϕ 87- 100	87	± 0.005	114	0.7	
910.126	ϕ 100- 125	-	± 0.005	150	0.7	
910.127	ϕ 125- 150	-	± 0.005	150	0.7	
910.128	ϕ 150- 175	-	± 0.005	150	0.7	
910.129	ϕ 175- 200	-	± 0.005	150	0.7	
910.130	ϕ 200- 225	-	± 0.007	150	0.7	
910.131	ϕ 225- 250	-	± 0.007	150	0.7	
910.132	ϕ 250- 275	-	± 0.007	150	0.7	
910.133	ϕ 275- 300	-	± 0.007	150	0.7	

Option:

836.535 Spare battery type V357

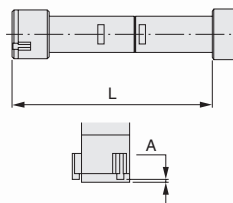
Sets

Item No.	Measuring range/mm	Setting rings ϕ /mm	Extension mm	Number of instruments	Price HRK
910.134	ϕ 6- 12	6, 8, 10	100	3	
910.135	ϕ 12- 20	16	150	2	
910.136	ϕ 20- 50	25, 40	150	4	
910.137	ϕ 50- 100	62, 87	150	4	

Digital three-point internal micrometers

Digital three-point internal micrometers with a large measuring range. With optional extensions, also for measuring in deep (blind) bores.

- Measuring range: ϕ 50 - 300 mm.
- Max. measuring depth: 1100 mm.
- Resolution: 0.001 mm.
- mm/inch conversion.
- ABS/INC switchable.
- On/off switch.
- Automatic switch-off.
- Reset/preset.
- Self-centering.
- Tungsten carbide measuring faces.
- Protection: IP54.
- Delivery in an aluminum carrying case with extension 150 mm.
- Separate instruments within measuring range ϕ 50 - 100 mm and the sets are delivered incl. setting ring(s).
- Setting rings are conform to factory standard.
- Power supply: 1 battery type V357.

MedioTehna



Extensions

Item No.	Extension mm	Price HRK
906.227	150	
906.228	500	
906.229	1000	

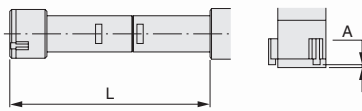

Item No.	Measuring range/mm	Setting ring ϕ /mm	Accuracy mm	Length L/mm	Length A/mm	Price HRK
906.904	ϕ 50 - 70	50	± 0.004	107	0.5	
906.905	ϕ 70 - 100	70	± 0.004	107	0.5	
906.906	ϕ 100 - 150	-	± 0.005	107	0.5	
906.907	ϕ 150 - 250	-	± 0.007	107	0.5	
906.908	ϕ 200 - 300	-	± 0.007	107	0.5	

Sets

Item No.	Measuring range/mm	Setting ring ϕ /mm	Number of instruments	Price HRK
906.909	ϕ 50 - 100	70	2	
906.910	ϕ 100 - 250	150	2	

Option

Item No.	Description	Price HRK
836.535	Spare battery type V357	

Digital three-point internal micrometers up to 1000 mm

Digital three-point internal micrometers with a large measuring range. With optional extensions, also for measuring in deep bores.

- Measuring range: \varnothing 200 - 1000 mm.
- Resolution: 0.001 mm.
- mm/inch conversion.
- ABS/INC switchable.
- On/off switch.
- Automatic switch-off.
- Reset/preset.
- Self-centering.
- Tungsten carbide measuring faces.
- Protection: IP54.
- Delivered incl. setting ring.
- Power supply: 1 battery type V357.



907.787

With interchangeable measuring bolts

The measuring range is extra large because of the interchangeable measuring bolts. The high accuracy of the measuring bolts enables exchanging without recalibrating the read-out.

- Max. measuring depth:
907.787: 750 mm,
907.788: 1750 mm.
- Accuracy:
 $\pm(1+0.02L) \mu\text{m}$ (L in mm).
- Delivery in a wooden case with extensions and setting ring.

MedioTehna



Item No.	Measuring range/mm	Setting ring \varnothing /mm	Length L/mm	Length A/mm	Extensions mm	Price HRK
907.787	\varnothing 200 - 500	200	105	0.5	150, 500	
907.788	\varnothing 200 - 1000	200	105	0.5	150, 500, 1000	

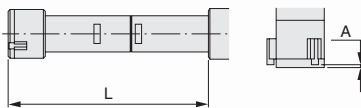

Option

Item No.	Description	Price HRK
836.535	Spare battery type V357	

Extensions

Item No.	Extension mm	Price HRK
906.227	150	
906.228	500	
906.229	1000	

Three-point internal micrometers

Three-point internal micrometers with a clever pistol-shaped base instrument for quick, easy and accurate measurements of internal measures such as (blind) bores. Easy single handed operation for both right and left handed use. Available as single instruments and as sets, with setting ring(s) and extension.

- Measuring range: \varnothing 6- 100 mm.
- Measuring depth: 0- 270 mm.
- Read-out depends on the type of dial indicator or measuring probe.
- Clamping shaft: \varnothing 8 mm.
- Self-centering.
- Excl. dial indicator or measuring probe.
- Tungsten carbide measuring faces.
- Setting rings are conform to factory standard.
- Delivery in an aluminum carrying case.



Separate instruments

Item No.	Measuring range/mm	Accuracy mm ¹	Setting ring \varnothing /mm	Extension mm	Length/mm		Price HRK
					L	A	
907.770	\varnothing 6- 8	\pm 0.004	8	100	50	2	
907.771	\varnothing 8- 10	\pm 0.004	8	100	50	2	
907.772	\varnothing 10- 12	\pm 0.004	10	100	50	2	
907.773	\varnothing 12- 16	\pm 0.004	16	150	65	0.5	
907.774	\varnothing 16- 20	\pm 0.004	16	150	65	0.5	
907.775	\varnothing 20- 25	\pm 0.004	25	150	91	0.5	
907.776	\varnothing 25- 30	\pm 0.004	25	150	91	0.5	
907.777	\varnothing 30- 40	\pm 0.004	40	150	97	0.5	
907.778	\varnothing 40- 50	\pm 0.005	40	150	97	0.5	
907.779	\varnothing 50- 63	\pm 0.005	62	150	112	0.5	
907.780	\varnothing 62- 75	\pm 0.005	62	150	112	0.5	
907.781	\varnothing 75- 88	\pm 0.005	87	150	112	0.5	
907.782	\varnothing 87- 100	\pm 0.005	87	150	112	0.5	

¹ Excl. accuracy of dial indicator or measuring probe.

Sets

Item No.	Measuring range/mm	Setting ring(s) \varnothing /mm	Number of pistol grips	Extension mm	Price HRK
907.783	\varnothing 6- 12	8, 10	1	100	
907.784	\varnothing 12- 20	16	1	150	
907.785	\varnothing 20- 50	25, 40	2	150	
907.786	\varnothing 50- 100	62, 87	1	150	

Dial bore gauge for through bores

Dial bore gauge consisting of a grip (clamping shaft \varnothing 8 mm), with a two point split contact point with a needle.

- Measuring range: 3 - 18 mm.
- Measuring elements: hardened steel.
- Measuring needles: hardened steel.
- Including standard dial indicator 0 - 3 mm / 0.01 mm.
- Constant measuring force as a result of a built-in spring, thus eliminating user influence.
- Delivery in a plastic case.

NEW

MedioTehna

PRICE

Item No.	Measuring range/mm	Measuring depth/mm	Number of inserts	Price HRK
910.326	3 - 4	20	4	
910.327	4 - 6	30	4	
910.328	6 - 10	40	4	
910.329	10 - 18	130	8	



910.329

Optional dial indicators

Item No.	Measuring range/mm	Graduation mm	Accuracy mm	Price HRK
Analog:				
907.933 ¹	0 - 10	0.01	—	
Digital (with determination of the reversal point):				
910.004 ¹	0 - 12.7	0.001	± 0.004	
909.250 ¹	0 - 12.5	0.002	± 0.015	
909.251 ¹	0 - 12.5	0.0005	± 0.006	
910.340 ²	0 - 15	0.0005	± 0.002	
Option:				
852.446	Probe extension 10 mm			

¹ Extension 10 mm 852.446 required (only for 910.326 and 910.327).

² Only suitable for 910.326 and 910.327.



910.327

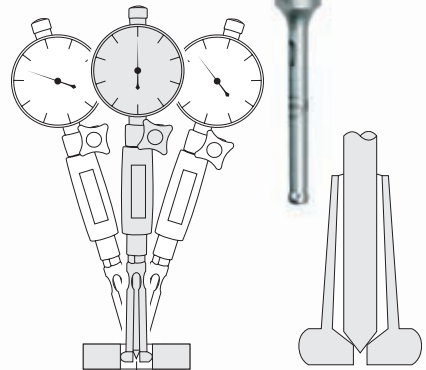

910.004



910.340

Internal measuring instruments

Internal measuring instruments used for measuring diameters of cylindrical bores and form deviations for instance roundness and cylindricity, compared to standards such as setting rings. In order to read out the measured values, any existing dial indicator or measuring probe with a clamping stem of $\varnothing 8$ mm can be used. The reversal point marks the diameter of the bores. When using digital indicators a model with a hold function for minimal measuring value is recommended. Please see the dial indicators section for these dial indicators.

- Measuring range: 6 - 450 mm.
- Read-out depends on the type of dial indicator or measuring probe.
- Incl. standard dial indicator 0 - 3 mm / 0.01 mm.
- Clamping shaft: $\varnothing 8$ mm.
- Self-centering (except 907.230).
- Interchangeable measuring inserts with tungsten carbide stylus tip (907.230 with spherical measuring face).
- Delivery in a plastic case or a wooden case incl. standard dial indicator and measuring inserts.

MedioTehna



907.230



907.231



907.232



907.233



907.235



907.236



907.237



907.235 + 907.933



907.235 + 907.933

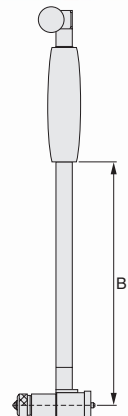

Item No.	Measuring range/mm	Effective measuring range/mm	Measuring depth (B)/mm	Number of probes	Price HRK
907.230	6 - 10	0.5	40	9	
907.231	10 - 18	0.5	100	9	
907.232	18 - 35	1.2	150	9	
907.233	35 - 50	1.2	150	4	
907.235	50 - 160	1.2	150	12	
907.236	160 - 250	1.2	400	5	
907.237	250 - 450	1.2	400	5	

Peacock internal measuring instruments

Internal measuring instruments used for measuring diameters of cylindrical bores and form deviations for instance roundness and cylindricity, compared to standards such as setting rings. In order to read out the measured values, any existing dial indicator or measuring probe with a clamping stem of $\varnothing 8$ mm can be used. The reversal point marks the diameter of the bores. When using digital indicators a model with a hold function for minimal measuring value is recommended. Please see the dial indicators section for these dial indicators.

- Measuring range: 6 - 400 mm.
- Read-out depends on the type of dial indicator or measuring probe.
- Clamping shaft: $\varnothing 8$ mm.
- Self-centering bridge.
- Interchangeable measuring inserts with tungsten carbide stylus tip.
- Delivery in a plastic case or a wooden case.
- Excl. dial indicator or measuring probe.



855.010



855.018



855.035



855.060



855.150



855.160



855.250



855.260

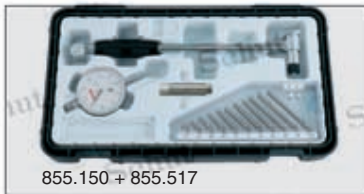

855.150 + 855.517



859.557 + 855.517

MedioTehna



855.150 + 855.517

Item No.	Measuring range/mm	Effective measuring range/mm	Measuring depth (B)/mm	Number of probes	Price HRK
855.010	6 - 10	0.5	50	9	
855.018	10 - 18	0.5	100	9	
855.035	18 - 35	1.2	150	9	
855.060	35 - 60	1.2	150	6	
855.150	50 - 150	1.2	150	11	
855.160	100 - 160	1.2	250	7	
855.250	160 - 250	1.2	250	10	
855.260	250 - 400	1.2	400	16	

Options:

- 855.517 Peacock dial indicator 0-5 mm, graduation 0.01 mm
- 859.557 Protection for dial indicator

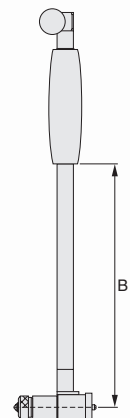

Setting instrument for internal measuring instruments

This instrument offers you the best way to accurately set the zero position of your internal measuring instruments with dial indicator. Gauge blocks are used to set the exact reference value. The special mounting hole assures that the centering device of the micrometer also functions when in use on this instrument, making the checking just as easy as measuring.

- Adjustment range: 18-400 mm.
- The setting instrument consists of a stand with double guidance and a flat measuring jaw.
- Excl. gauge blocks.
- Delivery in a wooden box.



Item No.	Adjustment range/mm	Price HRK
907.877	18-400	

Setting gauges for inside micrometers

Used for setting of inside micrometers.

- Measuring range: 50-275 mm.
- Delivery in a wooden case.



MedioTehna

Item No.	Length mm	Accuracy mm	Parallelism mm	Price HRK
910.005	50	±0.003	0.003	
910.006	75	±0.004	0.004	
910.007	100	±0.005	0.005	
910.008	150	±0.005	0.005	
910.009	200	±0.005	0.005	
910.010	250	±0.005	0.005	
910.011	275	±0.005	0.005	

Stick micrometers

- Measuring range: 50 - 600 mm.
- Graduation: 0.01 mm.
- Locking screw (except 906.078).
- Spherical tungsten carbide measuring faces: $\varnothing 8 \times 8$ mm (906.078/079: $\varnothing 9 \times 2.5$ mm).
- With insulating grips (only 906.083 - 906.099).
- Delivery in a wooden case.
- Excl. setting gauge.



906.080



906.096

MedioTehna



Item No.	Measuring range/mm	Accuracy mm	Price HRK
906.078	50 - 75	± 0.006	
906.079	75 - 100	± 0.006	
906.080	100 - 125	± 0.006	
906.081	125 - 150	± 0.008	
906.082	150 - 175	± 0.008	
906.083	175 - 200	± 0.008	
906.084	200 - 225	± 0.009	
906.085	225 - 250	± 0.009	
906.086	250 - 275	± 0.009	
906.087	275 - 300	± 0.009	
906.088	300 - 325	± 0.009	

Item No.	Measuring range/mm	Accuracy mm	Price HRK
906.089	325 - 350	± 0.009	
906.090	350 - 375	± 0.010	
906.091	375 - 400	± 0.010	
906.092	400 - 425	± 0.010	
906.093	425 - 450	± 0.010	
906.094	450 - 475	± 0.011	
906.095	475 - 500	± 0.011	
906.096	500 - 525	± 0.011	
906.097	525 - 550	± 0.011	
906.098	550 - 575	± 0.011	
906.099	575 - 600	± 0.012	

Stick micrometer sets

- Measuring range: 50 - 5000 mm.
- Measuring range micrometer:
 906.911 - 906.917: 50- 63 mm,
 906.918: 150- 175 mm,
 906.919 - 906.923: 1000- 1050 mm.
- Graduation: 0.01 mm.
- Accuracy:
 906.911 - 906.918: $\pm(3+n+L/50) \mu\text{m}$,
 906.919 - 906.923: $\pm(7+n+L/50) \mu\text{m}$
 (n = number of extensions,
 L = max. measuring length in mm).
- Locking screw.
- Spherical tungsten carbide measuring faces.
- With insulating grips
 (only 906.918 - 906.923).
- External diameter micrometer/extensions:
 906.911 - 906.917: 15.5 mm,
 906.918: 22 mm,
 906.919 - 906.923: 28 mm.
- Incl. setting gauge
 (only 906.911 - 917: 50 mm,
 906.918: 150 mm).
- Delivery in a wooden case.

MedioTehna



906.918

Item No.	Measuring range/mm	Number of extensions	Price HRK
906.911*	50- 63	–	
906.912	50- 100	2	
906.913	50- 150	3	
906.914	50- 300	5	
906.915	50- 500	6	
906.916	50-1000	8	
906.917	50-1500	10	
906.918	150-2000	9	
906.919*	1000- 1050	–	
906.920	1000-2000	5	
906.921	1000-3000	6	
906.922	1000-4000	7	
906.923	1000-5000	8	

* Single instrument (without extensions).

Digital stick micrometer sets

- Measuring range: 150 - 2000 mm.
- Measuring range micrometer: 150 - 175 mm.
- Resolution: 0.001 mm.
- Locking screw.
- Spherical tungsten carbide measuring faces.
- With insulating grips
 (only 906.797 - 906.799).
- External diameter micrometer/extensions:
 22 mm.
- Incl. setting gauge: 150 mm.
- Delivery in a wooden case.



906.796

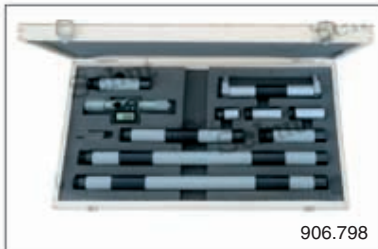

906.798

Item No.	Measuring range/mm	Number of extensions	Accuracy μm	Price HRK
906.796*	150- 175	–	6.5	
906.797	150-1000	6	29	
906.798	150-1500	8	41	
906.799	150-2000	9	52	

* Single instrument (without extensions).

Inside micrometers with interchangeable anvils

Screw thread micrometers for internal measurements of pitch diameters. The interchangeable anvils allow measurements of several kinds of screw thread.

- Measuring range: 75 - 300 mm.
- Graduation: 0.01 mm.
- Locking screw (125 - 300 mm).
- Insert shaft: $\phi 5$ mm.
- Delivery incl. setting gauge for metric thread, 60° flank angle.



Item No.	Measuring range/mm	Accuracy mm	Price HRK
Inside micrometers without inserts:			
906.924	75 - 100	± 0.035	
906.925	100 - 125	± 0.035	
906.926	125 - 150	± 0.035	
906.927	150 - 175	± 0.035	
906.928	175 - 200	± 0.045	
906.929	200 - 225	± 0.045	
906.930	225 - 250	± 0.045	
906.931	250 - 275	± 0.045	
906.932	275 - 300	± 0.055	

Item No.	Threads per inch	Price HRK
Inserts for Whitworth threads, 55° flank angle, per pair:		
906.940	60 - 48	
906.941	48 - 40	
906.942	40 - 32	
906.944	32 - 24	
906.945	24 - 18	
906.946	18 - 14	
906.947	14 - 10	
906.948	10 - 7	
906.949	7 - 4.5	
906.950	4.5 - 3.5	
906.951	Set 60 - 3.5	

Item No.	Pitch/mm	Price HRK
Inserts for metric threads, 60° flank angle, per pair:		
906.933	0.4 - 0.5	
906.934	0.6 - 0.9	
906.935	1 - 1.75	
906.936	2 - 3	
906.937	3.5 - 5	
906.938	5.5 - 7	
906.939	Set 0.4 - 7	

Item No.	Threads per inch	Price HRK
Inserts for UN, UNC and UNF threads, 60° flank angle, per pair:		
906.952	64 - 48	
906.953	44 - 28	
906.954	24 - 14	
906.955	13 - 9	
906.956	8 - 5	
906.957	4.5 - 3.5	
906.958	Set 64 - 3.5	

Internal micrometers

Internal micrometers with special measuring jaws for measurements in hard-to-reach places.

- Measuring range: 5 - 200 mm.
- Analog: graduation 0.01 mm, digital: resolution 0.001 mm.
- Tungsten carbide cylindrical measuring faces.
- Internal micrometers within measuring range 5 - 50 mm are delivered incl. setting ring.
- Delivery in a plastic case.

Analog

- Matt chrome-plated design.

Digital

- mm/inch conversion.
- ABS/INC switchable.
- Automatic switch-off.
- Reset/preset.
- Power supply: 1 battery type V357.



906.509



909.974

MedioTehna

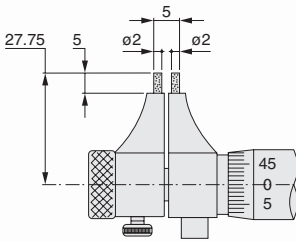

906.509 / 909.974

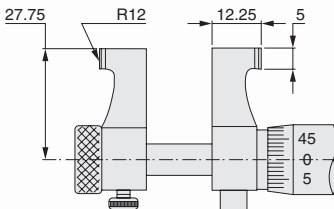

906.510-533 / 909.975-981



906.510-533 / 909.975-981



Item No.	Measuring range/mm	Accuracy mm	Price HRK
Analog:			
906.509	5- 30	±0.005	
906.510	25- 50	±0.006	
906.511	50- 75	±0.007	
906.512	75-100	±0.008	
906.530	100-125	±0.009	
906.531	125-150	±0.009	
906.532	150-175	±0.010	
906.533	175-200	±0.010	
Digital:			
909.974	5- 30	±0.005	
909.975	25- 50	±0.006	
909.976	50- 75	±0.007	
909.977	75-100	±0.008	
909.978	100-125	±0.009	
909.979	125-150	±0.009	
909.980	150-175	±0.010	
909.981	175-200	±0.010	
Option:			
836.535	Spare battery type V357		

Groove micrometers

Micrometers for measuring e.g. steps in bores and internal cross grooves. With double graduation for internal and external measurements. By means of the disk-shaped measuring faces the wide, depth and location of grooves in bores can be determined.

- Measuring range:
 - external measuring: 0 - 100 mm,
 - internal measuring: 1.6- 101.5 mm.
- Graduation: 0.01 mm.
- Accuracy: ± 0.01 mm.
- Diameter measuring faces:
 - 907.137: 6.5 mm,
 - 907.138-907.141: 13 mm.
- Double graduation.

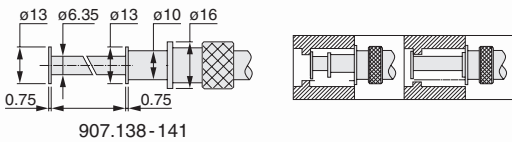
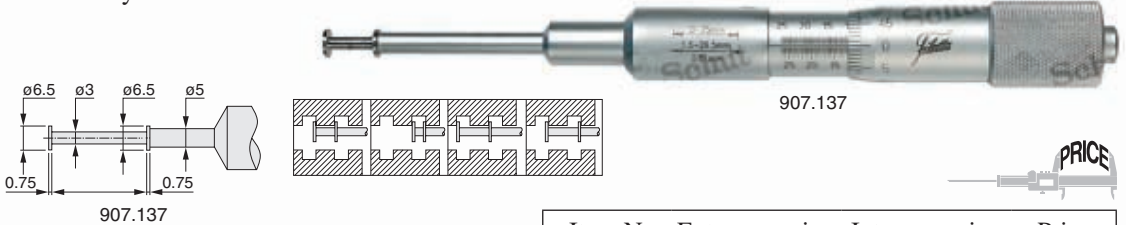

Item No.	Ext. measuring range/mm	Int. measuring range/mm	Price HRK
907.137	0- 25	1.6- 26.5	
907.138	0- 25	1.6- 26.5	
907.139	25- 50	26.5- 51.5	
907.140	50- 75	51.5- 76.5	
907.141	75- 100	76.5- 101.5	

Two-point internal measuring instruments

- Measuring range: 20- 150 mm.
- Graduation: 0.01 mm.
- Interchangeable measuring inserts.
- Delivery in a plastic case with measuring inserts.

MedioTehna

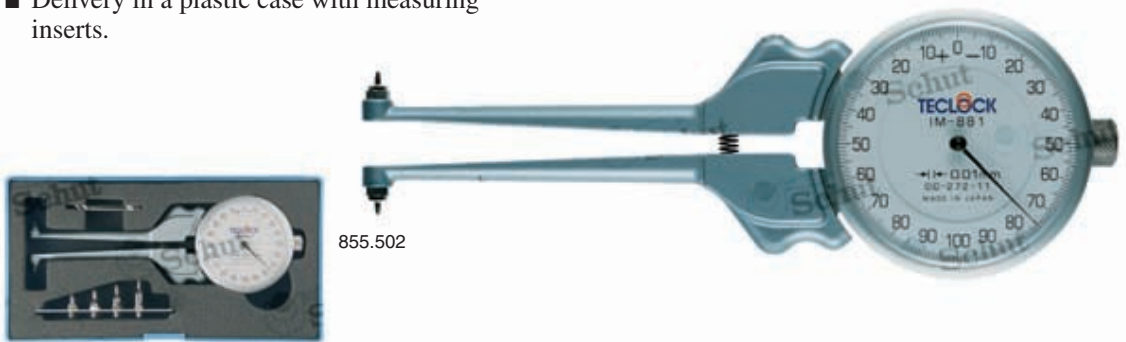

Item No.	Measuring range/mm	A _{max} mm	C _{min} mm	D _{max} mm	Price HRK
855.501	20- 34	60	2	3	
855.502	30- 60	75	2.5	5	
855.503	55- 150	90	4	9	

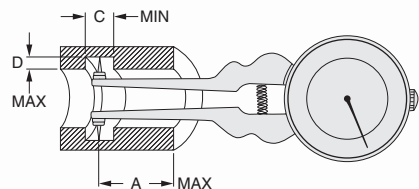

Diatest crankshaft meters

- Measuring range: 45 - 500 mm.
- Graduation: 0.01 mm.
- Rotatable dial.

- Delivery in a wooden case with dial indicator, counter-weight and extensions.



MedioTehna

Item No.	Measuring range/mm	Price HRK
831.469	45 - 150	
831.470	60 - 300	
831.471	60 - 500	

Options:

- 831.472 Separate dial indicator for 831.469
- 831.473 Counterweight for 831.469
- 831.474 Separate dial indicator for 831.470 and 831.471
- 831.475 Counterweight for 831.470 and 831.471

Crankshaft meters

- Measuring range: 60 - 500 mm.
- Graduation: 0.01 mm.
- Rotatable dial.
- Delivery in a wooden case with dial indicator, counter-weight and extensions.



907.919



907.917

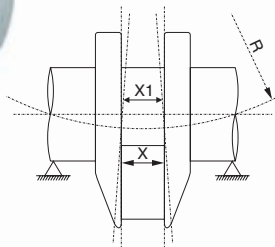

Item No.	Measuring range/mm	Price HRK
907.918	60 - 300	
907.919	60 - 500	
Option:		
907.917	Separate dial indicator	

Telescopic gauges

In places that are hard to reach with standard measuring instruments, you can use these telescopic gauges. The spring gauge is put into the bore and centers itself, after that you can turn on the locking screw. Then the gauge is pulled out and you can measure the result, for instance with a micrometer.

- Measuring range: 8 - 150 mm.
- Chrome finished.

MedioTehna

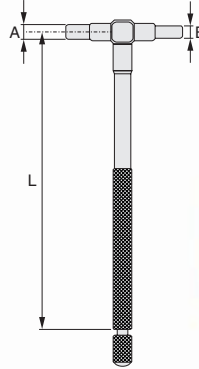
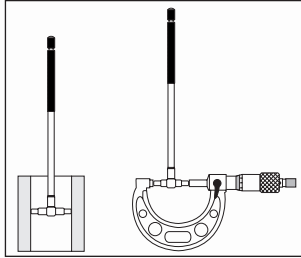

Individual gauges

Item No.	Measuring range/mm	Dimensions/mm			Price HRK
		L	A	B	
906.604	8 - 12.7	102	4	3	
906.605	12.7 - 19	102	5	4	
906.606	19 - 32	102	5	4	
906.607	32 - 54	127	7.5	6	
906.608	54 - 90	127	7.5	6	
906.609	90 - 150	127	7.5	6	

Set of gauges

Item No.	Measuring range/mm	Price HRK
906.610	8 - 150	



Plug gauges for small bores (blind/through)

Ideal for measuring of small bores (blind and through) and grooves. The spring gauge is put into the bore and centers itself, after that you can turn on the locking screw. Then the gauge is pulled out and you can measure the result, for instance with a micrometer. Separate set for blind bores and through bores.

- Measuring range: 3 - 13 mm (4 gauges: 3 - 5 mm, 5 - 7.5 mm, 7.5 - 10 mm and 10 - 13 mm).
- Chrome finished.

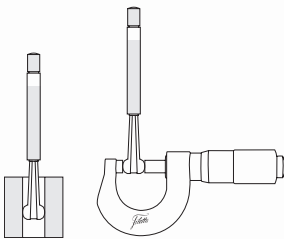

Set of gauges

Item No.	Description	Price HRK
907.747	For blind bores	
907.748	For through bores	



907.747



907.748



Digital internal measuring instrument

- Measuring range: 12.7 - 170 mm.
- Resolution: 0.1 mm.
- Accuracy: ± 0.2 mm.
- mm/inch conversion.
- On/off switch.
- Automatic switch-off.
- Reset.
- Hold function.
- Locking screw.
- Power supply: 1 battery type CR2032.

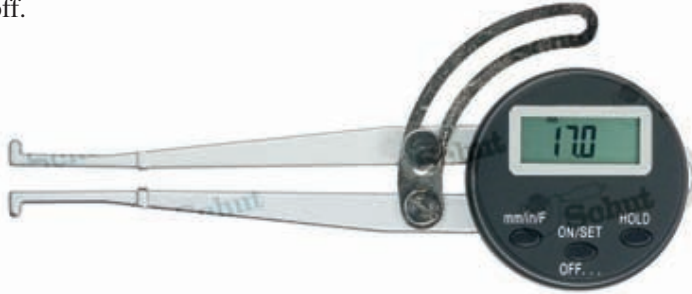

MedioTehna

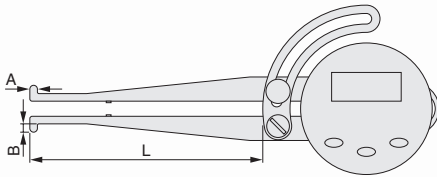

Item No.	Measuring range/mm	Length/mm			Price HRK
		L	A	B	
909.409	12.7 - 170	85	3	3	
Option: 495.157 Spare battery type CR2032					

Digital external measuring instrument

- Measuring range: 0 - 160 mm.
- Resolution: 0.1 mm.
- Accuracy: ± 0.2 mm.
- mm/inch conversion.
- On/off switch.
- Automatic switch-off.
- Reset.
- Hold function.
- Locking screw.
- Power supply: 1 battery type CR2032.



Item No.	Measuring range/mm	Length/mm			Price HRK
		L	A	B	
909.408	0 - 160	85	3	25	
Option: 495.157 Spare battery type CR2032					

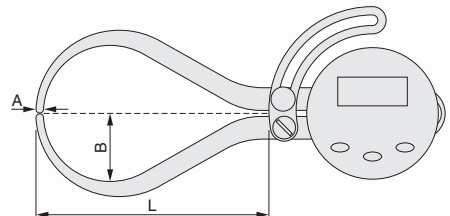

Digital internal measuring instruments

Digital internal measuring instruments for measurements of bores, internal grooves and other hard-to-reach places.

- Measuring range: 5 - 60 mm.
- Resolution: 0.005 mm. Digital-analog display changes automatically between 0.01, 0.02 and 0.05 mm (± 20 scale divisions).
- mm/inch conversion.
- ABS/INC switchable.
- Large LCD display, 340° rotatable.
- On/off switch.
- Automatic switch-off.
- Reset/preset.
- Hold and min/max functions.
- Adjustable tolerance limits.
- Measuring faces with different contact points.
- Delivery in an aluminum case.
- Power supply: 1 battery type CR2032.



MedioTehna

Item No.	Measuring range/mm	Accuracy mm	Length/mm			Contact point/mm	Price HRK
			L	A	B		
Range 10 mm:							
908.810	5 - 15	± 0.02	20	1	1.5	① R 0.3	
908.811	10 - 20	± 0.02	25	1.5	3.0	① R 0.3	
908.812	20 - 30	± 0.02	30	2	6.5	① R 0.5	
908.813	30 - 40	± 0.02	30	2.5	9.0	① R 0.5	
908.814	40 - 50	± 0.02	30	2.5	9.0	① R 0.5	
908.816	10 - 20	± 0.02	25	1.5	3.0	② $\varnothing 1.5$	
908.817	20 - 30	± 0.02	30	2	6.5	② $\varnothing 1.5$	
908.818	30 - 40	± 0.02	30	2.5	9.0	② $\varnothing 1.5$	
908.819	40 - 50	± 0.02	30	2.5	9.0	② $\varnothing 1.5$	
Range 20 mm:							
908.820	5 - 25	± 0.03	35	1	1.5	① R 0.3	
908.821	10 - 30	± 0.03	55	2	3.5	① R 0.5	
908.822	20 - 40	± 0.03	80	3	6.5	① R 0.5	
908.823	30 - 50	± 0.03	80	3	8.5	① R 0.5	
908.824	40 - 60	± 0.03	80	3	8.5	① R 0.5	
908.826	10 - 30	± 0.03	55	2	3.5	② $\varnothing 1.5$	
908.827	20 - 40	± 0.03	80	3	6.5	② $\varnothing 1.5$	
908.828	30 - 50	± 0.03	80	3	8.5	② $\varnothing 1.5$	
908.829	40 - 60	± 0.03	80	3	8.5	② $\varnothing 1.5$	
Option:							
495.157	Spare battery type CR2032						

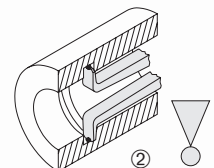
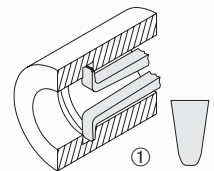
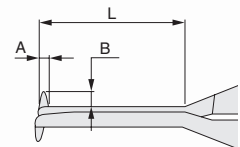

Internal measuring instruments

Internal measuring instruments for measurements of bores, internal grooves and other hard-to-reach places.

- Measuring range: 5 - 60 mm.
- Graduation: 0.01 mm.
- Rotatable dial.
- Adjustable tolerance markers.
- Measuring faces with different contact points.
- Delivery in an aluminum case.



MedioTehna



Item No.	Measuring range/mm	Accuracy mm	Length/mm			Contact point/mm	Price HRK
			L	A	B		
Range 10 mm:							
908.830	5 - 15	±0.02	20	1	1.5	① R 0.3	
908.831	10 - 20	±0.02	25	1.5	3.0	① R 0.3	
908.832	20 - 30	±0.02	30	2	6.5	① R 0.5	
908.833	30 - 40	±0.02	30	2.5	9.0	① R 0.5	
908.834	40 - 50	±0.02	30	2.5	9.0	① R 0.5	
908.836	10 - 20	±0.02	25	1.5	3.0	② ø1.5	
908.837	20 - 30	±0.02	30	2	6.5	② ø1.5	
908.838	30 - 40	±0.02	30	2.5	9.0	② ø1.5	
908.839	40 - 50	±0.02	30	2.5	9.0	② ø1.5	
Range 20 mm:							
908.840	5 - 25	±0.03	35	1	1.5	① R 0.3	
908.841	10 - 30	±0.03	55	2	3.5	① R 0.5	
908.842	20 - 40	±0.03	80	3	6.5	① R 0.5	
908.843	30 - 50	±0.03	80	3	8.5	① R 0.5	
908.844	40 - 60	±0.03	80	3	8.5	① R 0.5	
908.846	10 - 30	±0.03	55	2	3.5	② ø1.5	
908.847	20 - 40	±0.03	80	3	6.5	② ø1.5	
908.848	30 - 50	±0.03	80	3	8.5	② ø1.5	
908.849	40 - 60	±0.03	80	3	8.5	② ø1.5	

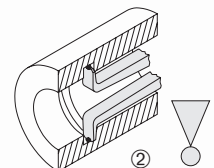
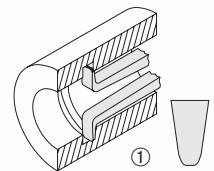
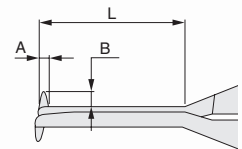

Digital external measuring instruments

Digital external measuring instruments for measurements of external grooves, axis diameters, wall thicknesses and other hard-to-reach places.

- Measuring range: 0-60 mm.
- Resolution: 0.005 mm. Digital-analog display changes automatically between 0.01, 0.02 and 0.05 mm (± 20 scale divisions).
- mm/inch conversion.
- ABS/INC switchable.
- Large LCD display, 340° rotatable.
- On/off switch.
- Automatic switch-off.
- Reset/preset.
- Hold and min/max functions.
- Adjustable tolerance limits.
- Measuring faces with different contact points.
- Delivery in an aluminum case.
- Power supply: 1 battery type CR2032.



908.850



Item No.	Measuring range/mm	Accuracy mm	Length/mm			Contact point/mm	Price HRK
			L	A	B		
Range 10 mm:							
908.850	0-10	± 0.02	40	3	8	① R 0.5	
908.851	10-20	± 0.02	40	3	8	① R 0.5	
908.852	20-30	± 0.02	40	3	8	① R 0.5	
908.853	30-40	± 0.02	40	3	8	① R 0.5	
908.854	40-50	± 0.02	40	3	8	① R 0.5	
908.855	0-10	± 0.02	40	3	8	② $\phi 1.5$	
908.856	10-20	± 0.02	40	3	8	② $\phi 1.5$	
908.857	20-30	± 0.02	40	3	8	② $\phi 1.5$	
908.858	30-40	± 0.02	40	3	8	② $\phi 1.5$	
908.859	40-50	± 0.02	40	3	8	② $\phi 1.5$	
Range 20 mm:							
908.860	0-20	± 0.03	80	6.5	25	① R 0.75	
908.861	10-30	± 0.03	80	6.5	25	① R 0.75	
908.862	20-40	± 0.03	80	6.5	25	① R 0.75	
908.863	30-50	± 0.03	80	6.5	25	① R 0.75	
908.864	40-60	± 0.03	80	6.5	25	① R 0.75	
908.865	0-20	± 0.03	80	6.5	25	② $\phi 1.5$	
908.866	10-30	± 0.03	80	6.5	25	② $\phi 1.5$	
908.867	20-40	± 0.03	80	6.5	25	② $\phi 1.5$	
908.868	30-50	± 0.03	80	6.5	25	② $\phi 1.5$	
908.869	40-60	± 0.03	80	6.5	25	② $\phi 1.5$	
Option:							
495.157	Spare battery type CR2032						

MedioTehna

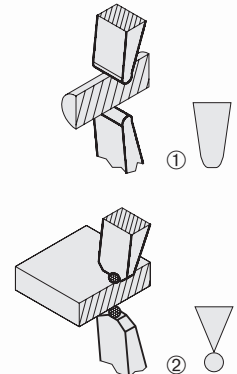
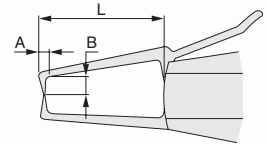

External measuring instruments

External measuring instruments for measurements of external grooves, axis diameters, wall thicknesses and other hard-to-reach places.

- Measuring range: 0-60 mm.
- Graduation: 0.01 mm.
- Rotatable dial.
- Adjustable tolerance markers.
- Measuring faces with different contact points.
- Delivery in an aluminum case.



908.870

MedioTehna



Item No.	Measuring range/mm	Accuracy mm	Length/mm			Contact point/mm	Price HRK
			L	A	B		
Range 10 mm:							
908.870	0-10	±0.02	40	3	8	① R 0.5	
908.871	10-20	±0.02	40	3	8	① R 0.5	
908.872	20-30	±0.02	40	3	8	① R 0.5	
908.873	30-40	±0.02	40	3	8	① R 0.5	
908.874	40-50	±0.02	40	3	8	① R 0.5	
908.875	0-10	±0.02	40	3	8	② ø 1.5	
908.876	10-20	±0.02	40	3	8	② ø 1.5	
908.877	20-30	±0.02	40	3	8	② ø 1.5	
908.878	30-40	±0.02	40	3	8	② ø 1.5	
908.879	40-50	±0.02	40	3	8	② ø 1.5	
Range 20 mm:							
908.880	0-20	±0.03	80	6.5	25	① R 0.75	
908.881	10-30	±0.03	80	6.5	25	① R 0.75	
908.882	20-40	±0.03	80	6.5	25	① R 0.75	
908.883	30-50	±0.03	80	6.5	25	① R 0.75	
908.884	40-60	±0.03	80	6.5	25	① R 0.75	
908.885	0-20	±0.03	80	6.5	25	② ø 1.5	
908.886	10-30	±0.03	80	6.5	25	② ø 1.5	
908.887	20-40	±0.03	80	6.5	25	② ø 1.5	
908.888	30-50	±0.03	80	6.5	25	② ø 1.5	
908.889	40-60	±0.03	80	6.5	25	② ø 1.5	

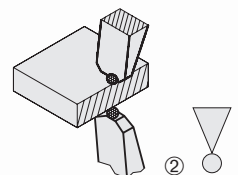
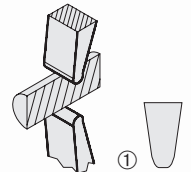
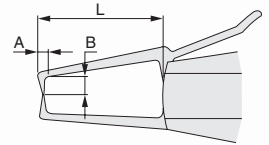

Digital thickness gauge

This digital thickness gauge has special, pointed measuring faces for measuring in hard-to-reach places of metal parts.

- Measuring range: 0- 15 mm.
- Resolution: 0.01 mm.
- Accuracy: ± 0.03 mm.
- mm/inch conversion.
- On/off switch.
- Reset.
- Weight: 100 g.
- Power supply:
1 battery type V357.

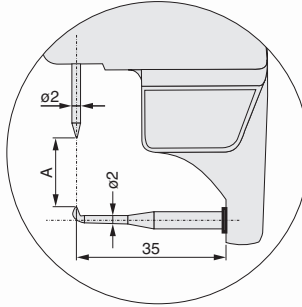

Item No.	Measuring face	Throat depth/mm	Price HRK
906.450	Pointed	35	
Option:			
836.535	Spare battery type V357		

MedioTehna

Digital thickness gauges

The shape of the measuring faces makes this digital thickness gauge especially suitable for measuring metal or plastic film, leather, paper, etc.

- Measuring range: 0- 25 mm.
- Resolution: 0.01 mm.
- Accuracy:
0- 15 mm: ± 0.03 mm,
0- 25 mm: ± 0.04 mm.
- mm/inch conversion.
- On/off switch.
- Reset.
- Weight: 100 g.
- Power supply: 1 battery type V357.

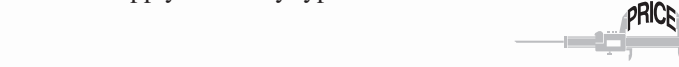
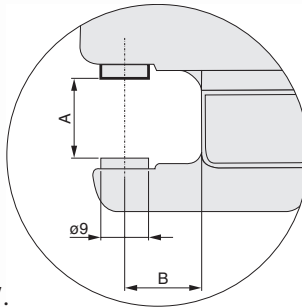

Item No.	Measuring range/mm	Measuring face ϕ /mm	Throat depth/mm	Price HRK
906.451	0- 15	9	15.0	
906.452	0- 25	9	14.5	
Option:				
836.535	Spare battery type V357			

906.451

Digital quick thickness gauges

- Measuring range: 0-25 mm.
- Resolution: 0.01 mm.
- Accuracy 910.313: ± 0.03 mm.
- Accuracy 910.314: ± 0.04 mm.
- mm/inch conversion.
- On/off switch.
- Reset.
- Anvil 910.313: $\phi 6.3$ mm.
- Pin measuring face 910.313: $\phi 5$ mm.
- Measuring face 910.314: $\phi 14.5$ mm.
- Power supply: 1 battery type V357.



910.313



910.314

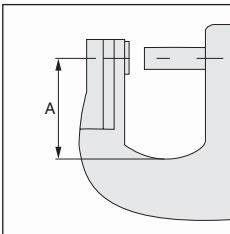

Item No.	Measuring range/mm	Throat depth A/mm	Price HRK
910.313	0- 12	19.7	
910.314	0- 25	25	
Option: 836.535 Spare battery type V357			

Digital external measuring instruments

- Measuring range: 0- 10 mm.
- Resolution: 0.01 mm.
- Repeatability: 0.01 mm.
- mm/inch conversion.
- Automatic switch-off.
- Reset.
- Max. measuring speed: 1.5 m/s.
- Non-interchangeable inserts.
- Power supply: 1 battery type V357.



MedioTehna

906.454



906.453

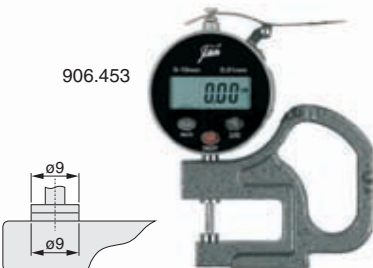

Item No.	Measuring range/mm	Measuring faces ϕ /mm	Throat depth/mm	Price HRK
906.453	0- 10	9	30	
906.454	0- 10	9	120	
Option: 836.535 Spare battery type V357				

Thickness gauges

- Measuring range: 0-20 mm.
- Graduation: 0.01 mm.
- Rotatable dial.

- Non-interchangeable inserts.
- Measuring face: \varnothing 10 mm (906.446: \varnothing 6 mm).



906.446



906.447



906.448

MedioTehna

Item No.	Measuring range/mm	Throat depth/mm	Price HRK
906.446	0-10	10	
906.447	0-10	30	
906.448	0-20	110	

Thickness gauges with roller measuring inserts

- Measuring range: 0-10 mm.
- Measuring face roller measuring inserts: 7 mm/ \varnothing 22 mm.
- Throat depth: 100 mm.
- Anvil: 28 x 22 mm (3 mm wheel height in anvil).

Analog

- Graduation: 0.01 mm.
- Rotatable dial with locking screw.
- Adjustable tolerance markers.

Digital

- Resolution: 0.01 mm.
- mm/inch conversion.
- On/off switch.
- Reset.
- Power supply: 1 battery type CR2032.



906.388

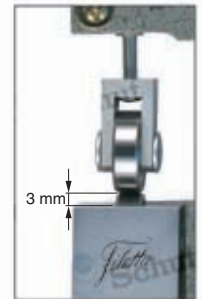

906.389

Item No.	Description	Price HRK
906.388	Thickness gauge	
906.389	Digital thickness gauge	
Option:		
495.157	Spare battery type CR2032	

Peacock external measuring instruments

- Measuring range: 0 - 10 mm.
- Graduation: 0.01 mm.
- Accuracy: ± 0.02 mm.
- Measuring force: approx. 1.8 N.
- Non-interchangeable measuring inserts.
- Ceramic measuring faces (except 855.761: steel).



855.761



855.751



855.750

NEW

Item No.	Measuring range/mm	Measuring faces ϕ /mm	Throat depth/mm	Price HRK
855.750	0 - 10	10	20	
855.761	0 - 10	10	20	
855.751	0 - 10	10	120	

External measuring instruments

- Measuring range: 0 - 10 mm.
- Graduation: 0.01 mm.
- Different types of inserts available, with hardened steel measuring faces.
- Throat depth: 50 mm.



853.002

853.007

Item No.	Type of insert	Price HRK
853.002	B	
853.003	C	
853.004	D	
853.005	E	
853.007	G	

Types of inserts

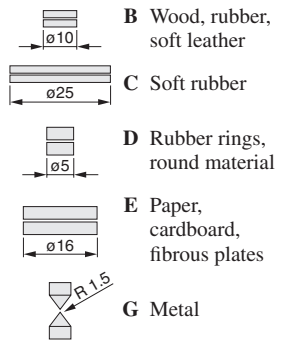

Thickness gauge for film measurement

- Measuring range: 0 - 1 mm.
- Graduation: 0.001 mm.
- Measuring force: approx. 3 N.
- Non-interchangeable measuring inserts.
- Throat depth: 25 mm.
- Frame with insulating grip.

- Ceramic measuring faces.
- Delivery in a plastic case with a manufacturer measuring report.

MedioTehna



Item No.	Measuring range/mm	Meas. faces ϕ /mm	Price HRK
907.859	0 - 1	10	



Peacock universal thickness gauge

Measuring instrument with dial indicator and adjustable anvil, multi-purpose.

- Span frame: 0 - 20 mm.
- Measuring range dial indicator: 10 mm.
- Graduation: 0.01 mm.
- Accuracy: ± 0.02 mm.
- Throat depth: 25 mm.
- With additional flat insert.

MedioTehna

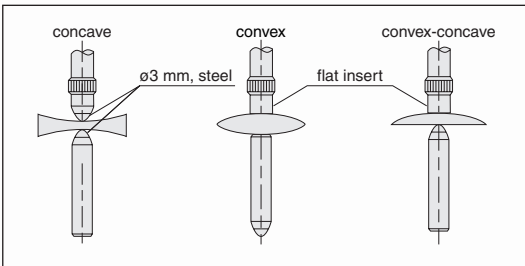

Item No.	Measuring range dial indicator/mm	Price HRK
855.752	0 - 10	

Tube wall thickness gauge

- Measuring range: 0 - 10 mm.
- Graduation: 0.01 mm.
- Measuring force: approx. 1 N.
- Throat depth: 25 mm.
- From inner diameter 8 mm.



Item No.	Measuring range/mm	Price HRK
853.137	0 - 10	

Thickness gauges

- Measuring range: 0 - 50 mm.
- Graduation: 0.1 mm.
- Different types of inserts.
- Hardened steel measuring faces.
- Other models available on request.



853.064



853.033



853.045



853.022

MedioTehna

Types of inserts

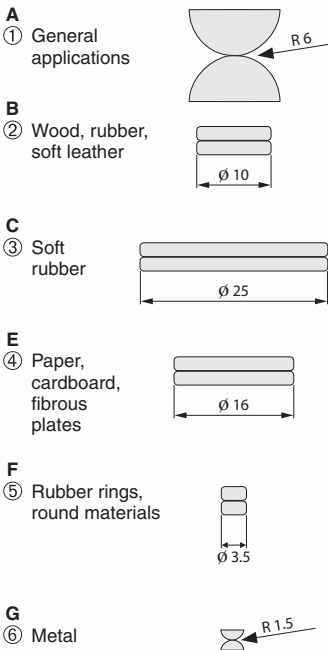

Item No.	Measuring range/mm	Type of insert	Throat depth/mm	Price HRK
853.022	0 - 10	②	15	
853.031	0 - 30	⑤	50	
853.032	0 - 30	②	50	
853.033	0 - 30	③	50	
853.034	0 - 30	④	50	
853.035	0 - 30	⑥	50	
853.037	0 - 30	①	50	
853.041	0 - 50	⑤	50	
853.042	0 - 50	②	50	
853.043	0 - 50	③	50	
853.044	0 - 50	④	50	
853.045	0 - 50	⑥	50	
853.047	0 - 50	①	50	
853.052	0 - 25	②	150	
853.053	0 - 25	③	150	
853.054	0 - 25	①	150	
853.055	0 - 25	④	150	
853.056	0 - 25	⑥	150	
853.062	0 - 25	②	300	
853.063	0 - 25	③	300	
853.064	0 - 25	①	300	
853.065	0 - 25	④	300	
853.066	0 - 25	⑥	300	
853.082	0 - 25	②	500	
853.083	0 - 25	③	500	
853.084	0 - 25	①	500	
853.085	0 - 25	④	500	
853.087	0 - 25	⑥	500	

Digital external measuring instruments

- Measuring range: 0-25 mm.
- Resolution: 0.01 mm.
- mm/inch conversion.
- On/off switch.
- Reset.
- Different types of inserts.
- Hardened steel measuring faces.
- Protection: IP54.
- Other models available on request.







853.074

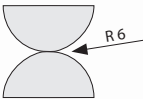

853.060

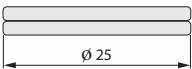
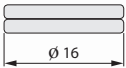
Types of inserts

- A**
① General applications

- B**
② Wood, rubber, soft leather

- C**
③ Soft rubber

- E**
④ Paper, cardboard, fibrous plates

- F**
⑤ Rubber rings, round materials

- G**
⑥ Metal

MedioTehna

Item No.	Measuring range/mm	Type of insert	Throat depth/mm	Price HRK
853.072	0-25	①	50	
853.073	0-25	②	50	
853.074	0-25	③	50	
853.075	0-25	④	50	
853.076	0-25	⑤	50	
853.077	0-25	⑥	50	
853.057	0-25	①	200	
853.078	0-25	②	200	
853.079	0-25	③	200	
853.080	0-25	④	200	
853.081	0-25	⑥	200	
853.060	0-25	①	300	
853.091	0-25	②	300	
853.092	0-25	③	300	
853.093	0-25	④	300	
853.094	0-25	⑥	300	

Universal measuring instruments

Robust universal measuring instruments for measuring by comparison, consisting of a steel precision cylinder with one fixed (adjustable) and one mobile measuring arm holder. The measuring direction is reversible by a simple turn of the adjusting screw at the end of the instruments. This feature enables measurements of internal and external dimensions. Clamping shaft 8H7 for dial indicator or measuring probe (measuring range 0-10 mm) not included. The nominal size is set with gauge blocks, setting rings or something similar.

Base instrument, with a wooden case

Item No.	Type	Measuring range (internal/external) in mm, with:				Price HRK
		Spherical disc inserts	Spherical needle insert $\phi 2 \times 5$ mm	Ball insert $\phi 3$ mm	Measuring disc $\phi 15 \times 4$ mm	
856.340	2-MR	29-254/9-234	38-263/0-225	36-261/2-227	46-256/16-226	
856.341	2L-MR	29-354/9-334	38-363/0-325	36-361/2-327	46-356/16-326	
856.342	2EL-MR	29-454/9-434	38-463/0-425	36-461/2-427	46-456/16-426	



MedioTehna

Measuring arms (2 needed)

Item No.	Length mm	Price HRK per piece
Type MA, with $\phi 3.5$ mm bore for interchangeable inserts:		
856.343	25	
856.344	50	
856.345	75	
856.346	100	
Type MB, with internal thread M6 for interchangeable measuring disc:		
856.347	30	
856.348	50	
Type MC, with bore 4H7 for various interchangeable inserts:		
856.349	30	
856.350	50	

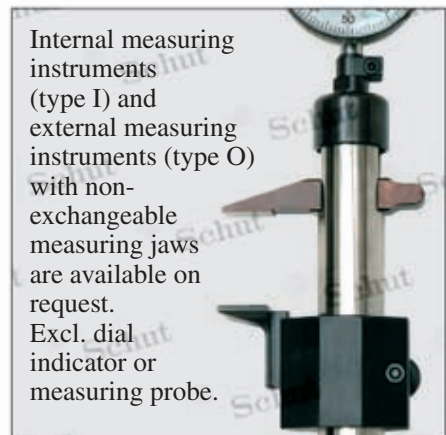
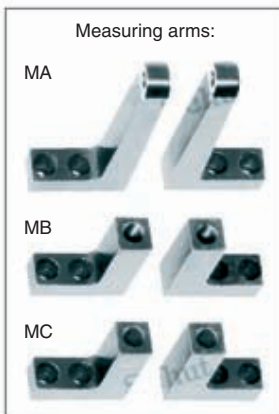

Universal measuring instruments (continued)

Interchangeable inserts for type MA

Item No.	Description (2 needed)	Price HRK per piece
856.351	Spherical disc insert	
856.372	Flat disc insert	
856.352	Spherical needle ø2 x 5 mm	
856.376	Spherical needle ø2 x 25 mm	
856.353	Ball insert ø3 mm	

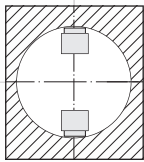

856.351:
measuring
of bores

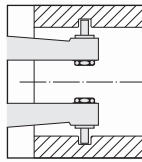

856.352:
measuring
of narrow
grooves

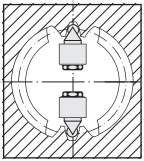

856.353: measuring
of internal gear teeth,
V-grooves, etc.

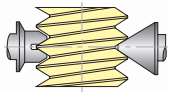

Available on request: inserts for thread
pitch diameters (metric: pitch 0.5-7.0;
BSW: 14-3.0 t.p.i.; UN: 32-3.0 t.p.i.). The
measuring anvils rotate to follow the helix
of the thread.

Interchangeable measuring disc for type MB

A measuring disc, which can be fitted by means of spacers and a support washer, is available for measuring arms MB with internal thread M6. For measuring of shoulders at different levels, locating flanges, etc.

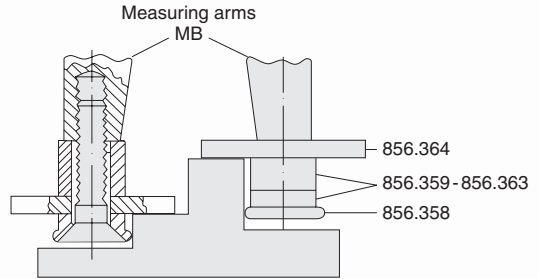

Item No.	Description (2 needed)	Price HRK per piece
856.358	Measuring disc ø15 x 4 mm	
856.359	Spacer 1 mm	
856.360	Spacer 2 mm	
856.361	Spacer 3 mm	
856.362	Spacer 6 mm	
856.363	Spacer 10 mm	
856.364	Support washer ø30 x 3 mm	

Example of
a complete
instrument with
measuring
arms type MB,
measuring discs
and a dial indicator.



MedioTehna

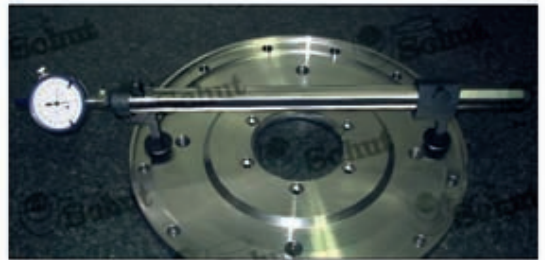

Extensions and connecting elements

Item No.	Description	Price HRK
856.354	Extension 300 mm	
856.355	Extension 500 mm	
856.356	Connecting element for measuring element and extension	
856.357	End cover for extension	

Before placing the extension the measuring direction has to be determined with the adjusting screw.

Dial indicators / Dial test indicators / Center instruments Edge finders / Probes

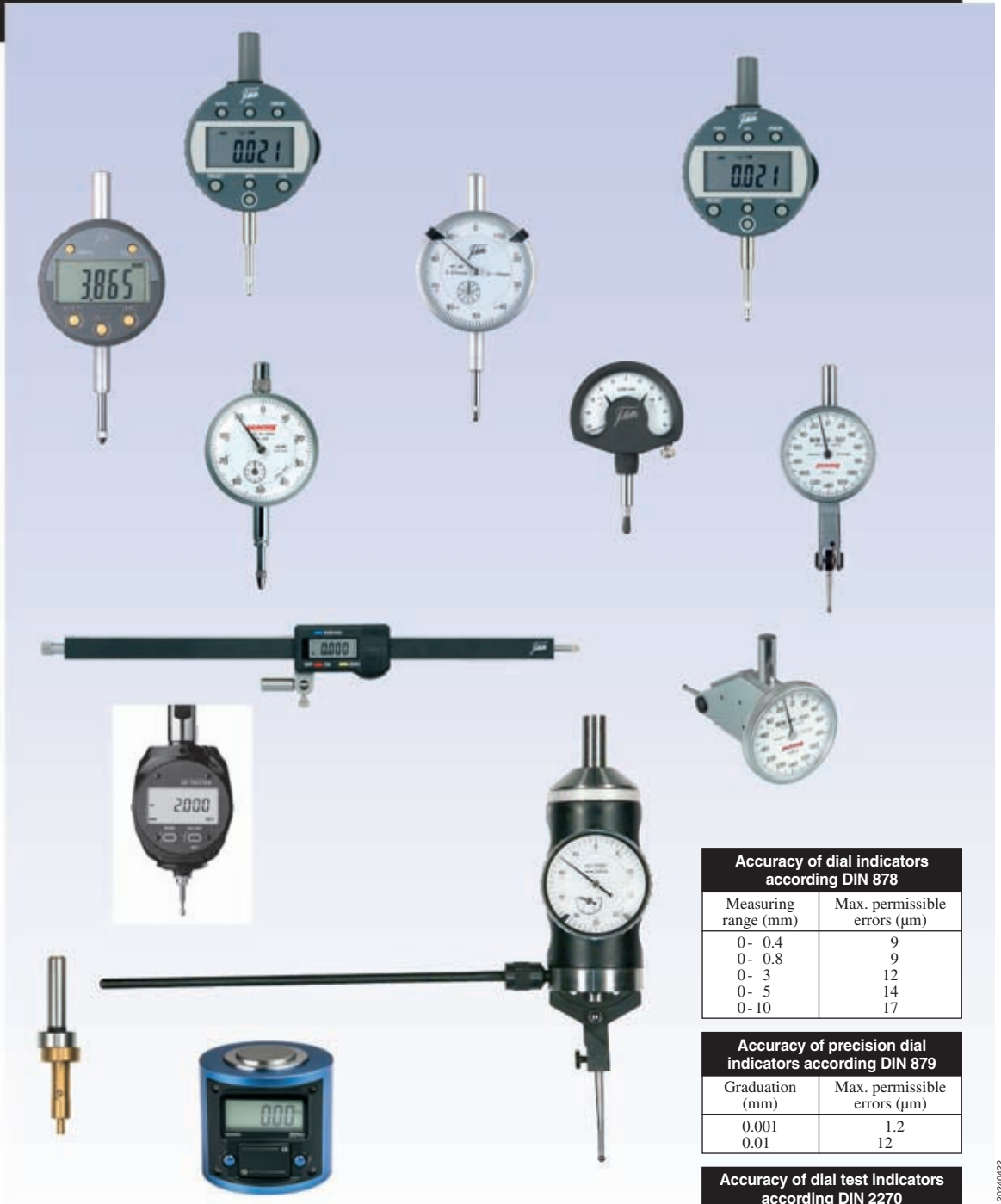

Accuracy of dial indicators according DIN 878	
Measuring range (mm)	Max. permissible errors (µm)
0- 0.4	9
0- 0.8	9
0- 3	12
0- 5	14
0-10	17

Accuracy of precision dial indicators according DIN 879	
Graduation (mm)	Max. permissible errors (µm)
0.001	1.2
0.01	12

Accuracy of dial test indicators according DIN 2270	
Graduation (mm)	Max. permissible errors (µm)
0.002	4
0.01	13

Digital dial indicators

Digital dial indicators for a favourable price.

- Measuring range: 0-50 mm.
- Resolution: 0.01 or 0.001 mm.
- mm/inch conversion.
- ABS/INC switchable.
- On/off switch.
- Reset.
- Clamping stem: $\varnothing 8$ mm.
- Dial diameter: 57 mm.
- Adjustable tolerance limits.
- Flat back and additional back with lug.
- Delivery in a plastic case with a manufacturer measuring report.
- Power supply: 1 battery type CR2025.



MedioTehna



Item No.	Measuring range/mm	Accuracy mm	Price HRK
With resolution 0.01 mm:			
907.634	0-12.5	± 0.02	
907.649	0-25	± 0.03	
907.652	0-50	± 0.04	
With resolution 0.001 mm:			
907.646	0-12.5	± 0.015	
Option:			
495.214	Spare battery type CR2025		

Absolute digital dial indicators

Absolute digital dial indicators with a function to set tolerance limits with clear optical Go (NoGo) reading.

- Measuring range: 0- 50 mm.
- Resolution: 0.01 mm or 0.001 mm.
- mm/inch conversion.
- ABS/INC switchable.
- With data output.
- Adjustable tolerance limits.
- **Tolerance display** by means of illuminated green LED at GO value.
- On/off switch.
- Reset/preset.
- Ceramic stylus tip.

MedioTehna

- Max. measuring speed: unlimited.
- Clamping stem: \varnothing 8 mm.
- Dial diameter: 60 mm.
- Reversible measuring direction.
- Flat back and additional back with lug.
- Protection: IP54.
- Delivery with a manufacturer measuring report.
- Power supply: 1 battery type CR2032.



906.870



906.618

USB interface:

- For data transfer to PC (e.g. Excel, Word).
- Operating system: Windows and other.
- PC connection: USB.
- No software or driver to install.
- Foot switch (optional).



909.687



906.619/910.038

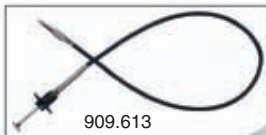

909.613

909.611

909.614

Item No.	Measuring range/mm	Resolution mm	Accuracy mm	Price HRK
910.221	0- 12.7	0.001	\pm 0.004	
910.222	0- 25.4	0.001	\pm 0.004	
910.223	0- 50.8	0.001	\pm 0.005	
906.870	0- 12.7	0.01	\pm 0.01	
906.871	0- 25.4	0.01	\pm 0.01	
906.872	0- 50.8	0.01	\pm 0.015	

Options:

- 495.157 Spare battery type CR2032
- 906.618^{1,2} USB interface
- 909.687 Footswitch for USB interface
- 910.038 Wireless USB receiver
- 906.619² Wireless transmitter
- 909.611 Retraction lever
- 909.613 Cable retraction device (0.4 m) (maximum travel 10 mm)
- 909.614 Retraction lever (maximum travel 12.7 mm)

¹ Standard configured for PC with English (US) keyboard. Also available on request for alternative keyboards.

² With micro-USB connection.

Absolute digital dial indicators

- Measuring range: 0 - 50.8 mm.
- Resolution: 0.01 mm or 0.001 mm.
- mm/inch conversion.
- ABS/INC switchable.
- LCD display 330° rotatable.
- Digimatic data output.
- On/off switch.
- Reset/preset.
- Ceramic stylus tip.
- Max. measuring speed: unlimited.
- Measuring force: ≤ 2 N.
- Clamping stem: $\varnothing 8$ mm.
- Dial diameter: 60 mm.
- Reversible measuring direction.
- With determination of the reversal point (only 910.004).

- Adjustable tolerance limits (except 910.004).
- Flat back.
- With additional back with lug (only 909.998, 910.001/004).
- Protection: IP54.
- Delivery with a manufacturer measuring report.
- Power supply: 1 battery type CR2032.



USB interface:

- For data transfer to PC (e.g. Excel, Word).
- Operating system: Windows and other.
- PC connection: USB.
- No software or driver to install.
- Foot switch (optional).

MedioTehna

PRICE



909.686



909.611

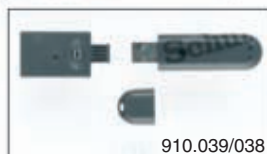

910.039/038



909.613

909.614

Item No.	Measuring range/mm	Resolution mm	Accuracy mm	Price HRK
909.998	0 - 12.7	0.001	± 0.004	
909.999	0 - 25.4	0.001	± 0.005	
910.000	0 - 50.8	0.001	± 0.006	
910.001	0 - 12.7	0.01	± 0.01	
910.002	0 - 25.4	0.01	± 0.01	
910.003	0 - 50.8	0.01	± 0.015	
For internal measurements:				
910.004	0 - 12.7	0.001	± 0.004	
With Bluetooth:				
910.079	0 - 12.7	0.001	± 0.004	
910.082	0 - 12.7	0.01	± 0.01	
Options:				
495.157	Spare battery type CR2032			
909.686 ^{1,2}	USB interface			
909.687	Footswitch for USB interface			
910.038	Wireless USB receiver			
910.039 ²	Wireless transmitter			
909.611	Retraction lever			
909.613	Cable retraction device (0.4 m) (maximum travel 10 mm)			
909.614	Retraction lever (maximum travel 12.7 mm)			

¹ Standard configured for PC with English (US) keyboard. Also available on request for alternative keyboards.

² For instruments with a Digimatic data output.

Digital dial indicators with high resolution

Digital dial indicators with digital and digital-analog read-out and a high resolution of 0.0005 mm.

- Measuring range: 0- 50.8 mm.
- Resolution: 0.0005.
- mm/inch conversion.
- ABS/INC switchable.
- On/off switch.
- With data output.
- USB-C data output: for data transfer to PC (e.g. Excel, Word), operating system Windows and other.
- Multifunctional functions: automatic switch-off, adjustable tolerance limits, reversible measuring direction, hold-function, min/max-function.
- Reset/preset.
- Clamping stem: $\varnothing 8$ mm.
- Dial diameter: 62 mm.
- Dial 270° rotatable.
- With determination of the reversal point.
- Protection: IP54.
- Delivery with USB-C and a manufacturer measuring report; excluding USB charger.
- Power supply: rechargeable battery.

NEW

PRICE



910.340

Item No.	Measuring range/mm	Resolution mm	Accuracy mm	Measuring force/N	Price HRK
910.340	0- 15	0.0005	± 0.002	≤ 1.5	
911.184	0- 25.4	0.0005	± 0.002	≤ 1.8	
911.185	0- 50.8	0.0005	± 0.004	≤ 2.3	

Option:
910.457* Bluetooth transmitter



* With USB-C connection.

Digital dial indicators

Digital dial indicators with digital and digital-analog read-out.

- Measuring range: 0- 12.5 mm.
- Resolution: 0.002 or 0.0005 mm.
- mm/inch conversion.
- ABS/INC switchable.
- On/off switch.
- Multifunctional functions: automatic switch-off, adjustable tolerance limits, reversible measuring direction.
- Reset/preset.
- Clamping stem: $\varnothing 8$ mm.
- Dial diameter: 62 mm.
- Dial 315° rotatable.
- With determination of the reversal point.
- Delivery in a plastic case.
- Power supply: 1 battery type CR2032.

PRICE



909.251

Item No.	Measuring range/mm	Resolution mm	Accuracy mm	Measuring force/N	Price HRK
909.250	0- 12.5	0.002	± 0.015	1.2	
909.251	0- 12.5	0.0005	± 0.006	1.2	

Option:
495.157 Spare battery type CR2032

Digital dial indicators

Universal digital indicators with both digital and digital-analog display of the measuring value, and can also be rotated over 340° to ensure easy read-out in all positions.

- Measuring range: 0- 12.7 mm.
- Resolution: 0.001 mm.
- Analog resolution: 0.001/0.002/0.01/0.02/0.05 mm.
- mm/inch conversion.
- ABS/INC switchable.
- On/off switch.
- Automatic switch-off.
- Reset/preset.
- Clamping stem: $\varnothing 8$ mm.
- Dial diameter: 61 mm.
- Dial 340° rotatable.
- Reversible measuring direction.
- Adjustable tolerance limits.
- Protection: IP54.
- Delivery in a plastic case.
- Power supply: 1 battery type CR2032.



907.879

Item No.	Measuring range/mm	Accuracy mm	Price HRK
907.879	0- 12.7	± 0.01	
907.878	0- 12.7	± 0.005	
Option:			
495.157	Spare battery type CR2032		

MedioTehna

Digital indicators

- Measuring range: 0- 100 mm.
- Resolution: 0.01 mm.
- mm/inch conversion.
- On/off switch.
- Reset.
- Clamping shaft: $\varnothing 6$ mm.
- Clamping stem: $\varnothing 8$ mm.
- Insert thread: M2.5.
- Power supply: 1 battery type V357.



910.312



Item No.	Measuring range/mm	Measuring force/N	Total length/mm	Price HRK
910.311	0- 50	< 2.5	148	
910.312	0- 100	< 3.2	330	
Option:				
836.535	Spare battery type V357			



910.312

Absolute horizontal digital dial indicators

- Measuring range: 0-30 mm.
- Resolution: 0.001 mm.
- mm/inch conversion.
- Digimatic data output.
- On/off switch.
- Reset/preset.
- Ceramic stylus tip.
- With dovetail joint (incl. lug) and clamping stem \varnothing 8 mm.
- Measuring force: \leq 2 N.

- Reversible measuring direction.
- Protection: IP54.
- Delivery with a manufacturer measuring report.
- Power supply:
 - 910.085: 1 battery type CR1632,
 - 910.086: 1 battery type CR2032.

USB interface and wireless USB receiver and transmitter available on request.



910.085

PRICE

Item No.	Measuring range/mm	Resolution mm	Accuracy mm	Price HRK
910.085	0-12.7	0.001	\pm 0.005	
910.086	0-30	0.001	\pm 0.006	
Options:				
497.955	Spare battery type CR1632			
495.157	Spare battery type CR2032			

MedioTehna

Digital dial indicator with calculation function

Robust digital dial indicator with built-in calculation function for easy determination of diameters by means of measuring a curved surface. Suitable for measuring both inside and outside diameters and multifunctional dial indicator applications. Delivery with measuring bases of 10, 20, 30, 60 and 100 mm.

- Measuring range: 0-13 mm.
- Resolution: 0.005 mm.
- mm/inch conversion.
- On/off switch.
- Reset.

- Hold function.
- Clamping stem: \varnothing 8 mm.
- Aluminum construction.
- Delivery in a plastic case.
- Power supply: 1 battery type CR2032.



Item No.	Measuring range/mm	Accuracy mm	Price HRK
907.884	0-13	\pm 0.005*	
Option:			
495.157	Spare battery type CR2032		

* Accuracy of the indicator without the use of measuring bases. The accuracy with measuring bases depends on the radius and form deviation of the workpiece.



Dial indicators 0.01 mm

Indicators with an excellent price-performance ratio.

- Measuring range: 0- 10 mm.
- Graduation: 0.01 mm.
- Clamping stem: \varnothing 8 mm.
- Dial diameter: 55 mm.
- Rotatable dial.
- Adjustable tolerance markers.
- Flat back.
- Delivery with a manufacturer measuring report.



907.930



Item No.	Measuring range/mm	Price HRK
907.928	0- 3	
907.929	0- 5	
907.930	0- 10	
Option:		
908.799	Back with lug	

Dial indicators 0.01 mm

Indicators with a large dial and a locking screw. Shockproof design.

- Measuring range: 0- 10 mm.
- Graduation: 0.01 mm.
- Clamping stem: \varnothing 8 mm.
- Dial diameter: 60 mm.
- Rotatable dial.
- Adjustable tolerance markers.
- Locking screw.
- Flat back.
- Delivery with a manufacturer measuring report.

MedioTehna



907.933

907.933
+ 906.359

Item No.	Measuring range/mm	Price HRK
907.931	0- 3	
907.932	0- 5	
907.933	0- 10	
Options:		
908.987	Back with lug	
906.359	Retraction lever	



Dial indicators 0.01 mm

Indicators with a large measuring range.

- Measuring range: 0- 100 mm.
- Graduation: 0.01 mm.
- Clamping stem: \varnothing 8 mm.
- Rotatable dial.
- Adjustable tolerance markers (except 907.916).
- Locking screw.
- Flat back.
- Delivery with a manufacturer measuring report.



907.934



907.935

907.936



907.916

Item No.	Measuring range/mm	Dial \varnothing /mm	Price HRK
907.934	0- 25	60	
907.935	0- 30	60	
907.936	0- 50	76	
907.916	0-100	80	

Options:
 908.987¹ Back with lug
 908.988² Back with lug

¹ For 907.934/935.

² For 907.936/916.

Splashproof dial indicators 0.01 mm

Indicators with splashproof design.

- Measuring range: 0- 10 mm.
- Graduation: 0.01 mm.
- Clamping stem: \varnothing 8 mm.
- Dial diameter: 55 mm.
- Rotatable dial.
- Shockproof.
- Adjustable tolerance markers.
- Locking screw.
- Back with lug.
- Protection: IP54.
- Conforms to factory standard.



908.779

Item No.	Measuring range/mm	Price HRK
908.777	0- 3	
908.778	0- 5	
908.779	0- 10	

MedioTehna

Miniature dial indicator 0.01 mm

Indicator with very small dimensions and an excellent price-performance ratio.

- Measuring range: 0- 10 mm.
- Graduation: 0.01 mm.
- Clamping stem: \varnothing 8 mm.
- Dial diameter: 40 mm.
- Rotatable dial.
- Adjustable tolerance markers.
- Locking screw.
- Flat back.
- Delivery with a manufacturer measuring report.



907.925



Item No.	Measuring range/mm	Price HRK
Graduation 0.01 mm:		
907.925	0- 3	
907.926	0- 5	
907.927	0- 8	
907.914	0- 10	
Option:		
908.986	Back with lug	

Dial indicators 0.001 mm

Indicators with micrometer reading. Shockproof design.

- Measuring range: 0- 5 mm.
- Graduation: 0.001 mm.
- Clamping stem: \varnothing 8 mm.
- Dial diameter: 60 mm.
- Rotatable dial.
- Scale numbering: 0- 100- 0.
- Shockproof.
- Adjustable tolerance markers.
- Locking screw.
- Flat back.
- Delivery with a manufacturer measuring report.



907.921



Item No.	Measuring range/mm	Price HRK
907.921	0- 1	
907.922	0- 2	
907.923	0- 3	
907.924	0- 5	
Option:		
908.987	Back with lug	

MedioTehna

Peacock dial indicators 0.1 and 0.01 mm

- Measuring range: 0 - 80 mm.
- Graduation: 0.1 or 0.01 mm.
- Clamping stem: $\varnothing 8$ mm (except 855.557: $\varnothing 10$ mm and 855.589: $\varnothing 14$ mm).
- Rotatable dial.
- Adjustable tolerance markers.
- Flat back or back with lug*.
- DIN 878.



MedioTehna

Item No.	Measuring range/mm	Dial \varnothing /mm	Max. hysteresis mm	Measuring force/N	Accuracy mm	Price HRK
Graduation 0.01 mm:						
855.547	0 - 4	36	0.004	<1.4	± 0.018	
855.536	0 - 3	40	0.004	<1.4	± 0.016	
855.517	0 - 5	53	0.004	<1.4	± 0.015	
855.507	0 - 10	53	0.004	<1.4	± 0.015	
855.508*	0 - 10	53	0.004	<1.4	± 0.015	
855.527*	0 - 20	66.5	0.005	<2.0	± 0.025	
855.537*	0 - 30	76	0.007	<2.2	± 0.030	
855.557*	0 - 50	83	0.008	<2.5	± 0.100	
Graduation 0.1 mm:						
855.589*	0 - 80	112	—	<2.5	± 0.100	

* Back with lug.

Peacock dial indicators 0.005 and 0.001 mm

- Measuring range: 0-5 mm.
- Graduation: 0.005 or 0.001 mm.
- Clamping stem: $\varnothing 8$ mm.
- Rotatable dial.
- Flat back or back with lug*.
- DIN 878.



Item No.	Measuring range/mm	Dial \varnothing /mm	Max. hysteresis mm	Measuring force/N	Accuracy mm	Price HRK
Graduation 0.005 mm:						
855.535*	0-3	47	0.004	<1.4	± 0.012	
Graduation 0.001 mm:						
855.509	0-1	53	0.003	<1.5	± 0.006	
855.525*	0-2	66.5	0.003	<1.5	± 0.007	
855.555*	0-5	66.5	0.003	<1.5	± 0.010	

* Back with lug.

Peacock dial indicators with back plunger

The back plunger dial indicator is characterized with easy handling since the spindle with the contact point is moving in the direction perpendicular to the dial face and the gauge is more compact. The dial indicator of this type is convenient for use in achieving a parallelism in machine guides and for applications where most other dial indicators are not applicable, give too great of a measurement error, or are difficult to read due to the applied arrangement.

- Measuring range: 0-5 mm.
- Graduation: 0.01 mm.
- Accuracy: ± 0.018 mm.
- Repeatability: 0.003 mm.
- Max. hysteresis: ± 0.004 mm.
- Measuring force: <1.4 N.
- Rotatable dial.
- Scale numbering: 0-100.
- DIN 878.

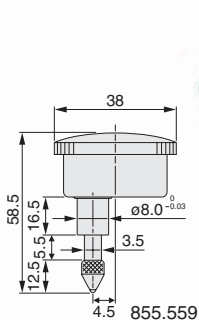
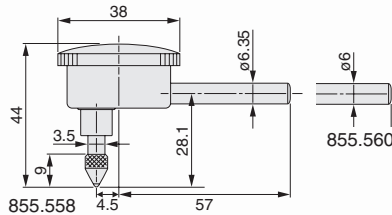

Item No.	Measuring range/mm	Clamping stem \varnothing /mm	Price HRK
855.558	0-5	6.35	
855.560	0-5	6	
Clamping stem on back side:			
855.559	0-5	8	

Precision dial indicator

Highly accurate dial indicator for measurements from a fixed reference point. Very suitable for internal measuring instruments and dial indicator stands for example.

- Measuring range: 0.1 mm.
- Graduation: 0.001 mm.
- Measuring force: <2 N.
- Clamping stem: \varnothing 8 mm.
- Travel: 3 mm.
- Adjustable tolerance markers.
- Fine adjustment.
- Delivery in a plastic case with a manufacturer measuring report.



MedioTehna



Item No.	Measuring range/mm	Dial \varnothing /mm	Price HRK
907.939	0.1	63.5	

Precision dial indicators

- Measuring range: 0.06 mm.
- Graduation: 0.0005 mm or 0.001 mm.
- Measuring force: approx. 1 N.
- Clamping stem: \varnothing 28 mm.
- Shockproof.
- Fine adjustment.
- Delivery with an inspection report.

For dial indicator stands see dial indicator stands elsewhere in this catalog.



Item No.	Measuring range/mm	Resolution mm	Scale numbering	Price HRK
906.332	0.03	0.0005	15-0-15	
906.333	0.06	0.001	30-0-30	

906.333

Inserts and extensions

Most dial indicators are equipped with an interchangeable insert with thread M2.5. Besides the inserts shown below various other types are available.

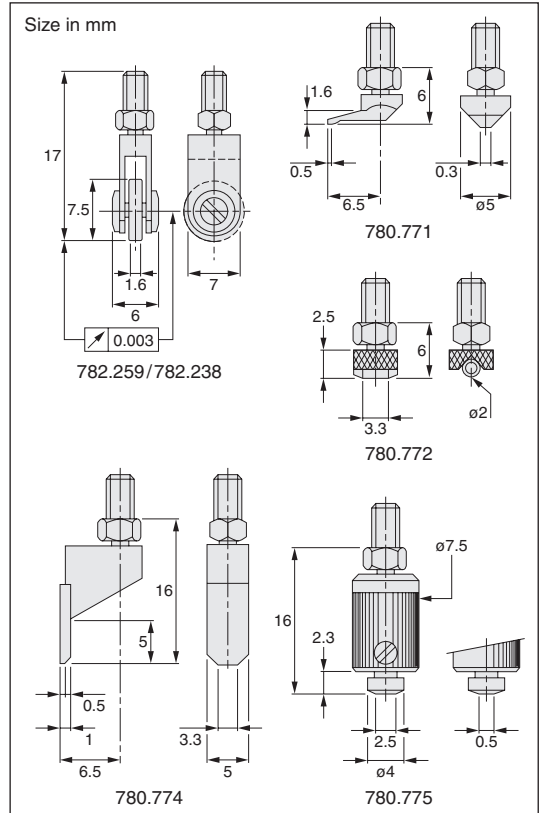
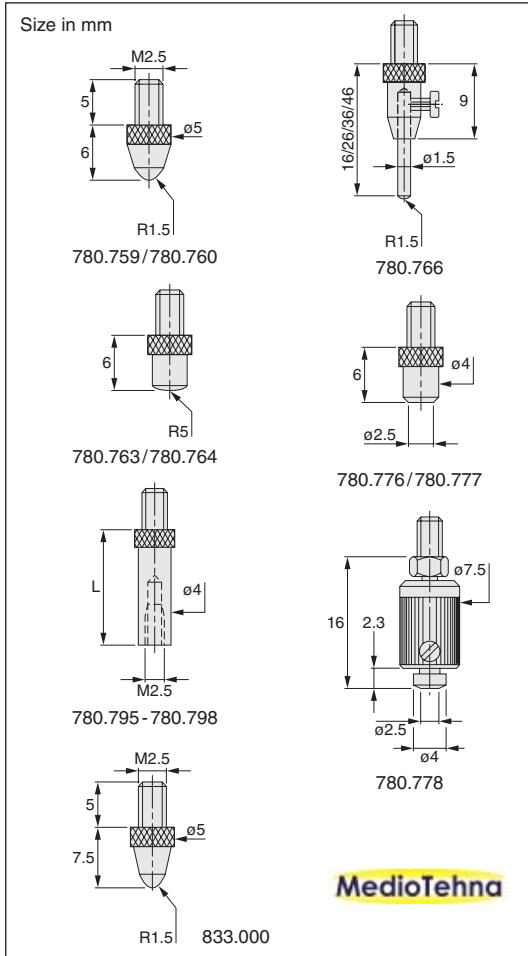

Item No.	Type	Price HRK
Ball radius 1.5 mm:		
780.759	Steel	
780.760	Tungsten carbide	
780.766	4 interchangeable inserts	
Ball radius 5 mm:		
780.763	Steel	
780.764	Tungsten carbide	
Flat:		
780.776	Steel	
780.777	Tungsten carbide	
780.778	Flat, adjustable meas. face	

Item No.	Type	Price HRK
Special forms:		
782.259	Roller with a cylindrical measuring face	
782.238	Roller with a ball-shaped measuring face	
780.771	Offset point	
780.772	Cylindrical point	
780.774	Offset line contact face	
780.775	V-shaped adjustable point	
Extensions:		
780.795	10 mm	
780.796	15 mm	
780.797	20 mm	
780.798	40 mm	
Special probe head:		
833.000	Ceramic ball ø3 mm	

Käfer inserts

Inserts with thread M2.5. The inserts are made of steel unless otherwise indicated; tungsten carbide (TC), ruby (R) or sapphire (S).

MedioTehna

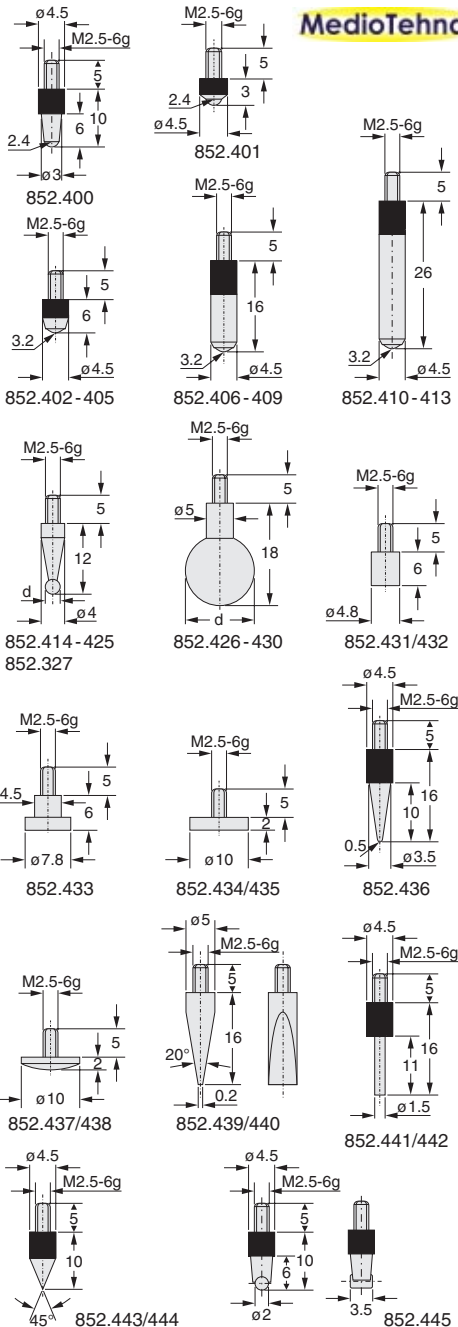

Item No.	Description	Price
Ball probes:		
852.400	$d = 2.4 \text{ mm}$ $l = 10 \text{ mm}$	
852.401	$d = 2.4 \text{ mm}$ $l = 3.0 \text{ mm}$	
852.402	$d = 3.2 \text{ mm}$ $l = 6.0 \text{ mm}$	
852.403	$d = 3.2 \text{ mm}$ $l = 6.0 \text{ mm}$	TC
852.404	$d = 3.2 \text{ mm}$ $l = 6.0 \text{ mm}$	R
852.405	$d = 3.2 \text{ mm}$ $l = 6.0 \text{ mm}$	S
852.406	$d = 3.2 \text{ mm}$ $l = 16 \text{ mm}$	
852.407	$d = 3.2 \text{ mm}$ $l = 16 \text{ mm}$	TC
852.408	$d = 3.2 \text{ mm}$ $l = 16 \text{ mm}$	R
852.409	$d = 3.2 \text{ mm}$ $l = 16 \text{ mm}$	S
852.410	$d = 3.2 \text{ mm}$ $l = 26 \text{ mm}$	
852.411	$d = 3.2 \text{ mm}$ $l = 26 \text{ mm}$	TC
852.412	$d = 3.2 \text{ mm}$ $l = 26 \text{ mm}$	R
852.413	$d = 3.2 \text{ mm}$ $l = 26 \text{ mm}$	S
852.414	$d = 1.0 \text{ mm}$ $l = 12 \text{ mm}$	
852.420	$d = 1.0 \text{ mm}$ $l = 12 \text{ mm}$	TC
852.327	$d = 1.5 \text{ mm}$ $l = 12 \text{ mm}$	
852.415	$d = 2.0 \text{ mm}$ $l = 12 \text{ mm}$	
852.421	$d = 2.0 \text{ mm}$ $l = 12 \text{ mm}$	TC
852.416	$d = 3.0 \text{ mm}$ $l = 12 \text{ mm}$	
852.422	$d = 3.0 \text{ mm}$ $l = 12 \text{ mm}$	TC
852.417	$d = 4.0 \text{ mm}$ $l = 12 \text{ mm}$	
852.423	$d = 4.0 \text{ mm}$ $l = 12 \text{ mm}$	TC
852.418	$d = 5.0 \text{ mm}$ $l = 12 \text{ mm}$	
852.424	$d = 5.0 \text{ mm}$ $l = 12 \text{ mm}$	TC
852.419	$d = 6.0 \text{ mm}$ $l = 12 \text{ mm}$	
852.425	$d = 6.0 \text{ mm}$ $l = 12 \text{ mm}$	TC
852.426	$d = 7.0 \text{ mm}$ $l = 18 \text{ mm}$	
852.427	$d = 8.0 \text{ mm}$ $l = 18 \text{ mm}$	
852.428	$d = 9.0 \text{ mm}$ $l = 18 \text{ mm}$	
852.429	$d = 10.0 \text{ mm}$ $l = 18 \text{ mm}$	
852.430	$d = 11.0 \text{ mm}$ $l = 18 \text{ mm}$	
Flat probes:		
852.431	$d = 4.8 \text{ mm}$ $l = 6 \text{ mm}$	
852.432	$d = 4.8 \text{ mm}$ $l = 6 \text{ mm}$	TC
852.433	$d = 7.8 \text{ mm}$ $l = 6 \text{ mm}$	
852.434	$d = 10.0 \text{ mm}$ $l = 2 \text{ mm}$	
852.435	$d = 10.0 \text{ mm}$ $l = 2 \text{ mm}$	TC
Spherical probes:		
852.436	conical $l = 16 \text{ mm}$	
852.437	$d = 10.0 \text{ mm}$ $l = 2.0 \text{ mm}$	
852.438	$d = 10.0 \text{ mm}$ $l = 2.0 \text{ mm}$	TC
Knife-edged probes:		
852.439	$d = 5.0 \text{ mm}$ $l = 16 \text{ mm}$	
852.440	$d = 5.0 \text{ mm}$ $l = 16 \text{ mm}$	TC
Needle-shaped probes:		
852.441	$d = 1.5 \text{ mm}$ $l = 16 \text{ mm}$	
852.442	$d = 1.5 \text{ mm}$ $l = 16 \text{ mm}$	TC
Tapered probes:		
852.443	$d = 4.5 \text{ mm}$ $l = 10 \text{ mm}$	
852.444	$d = 4.5 \text{ mm}$ $l = 10 \text{ mm}$	TC
Probe with cylindrical measuring face:		
852.445	$d = 2 \times 3.5 \text{ mm}$ $l = 10 \text{ mm}$	

Extensions for inserts

Steel extensions for inserts with thread M2.5.

Item No.	Length mm	Price HRK
Extensions with A = ø 4 mm:		
852.446	10	
852.447	15	
852.448	20	
852.449	25	
852.450	30	
852.451	35	
852.452	40	
852.453	45	
852.454	50	
852.455	55	
852.456	60	
852.457	65	
852.458	70	
852.459	75	
852.460	80	
852.461	85	
852.462	90	
852.463	95	
852.464	100	

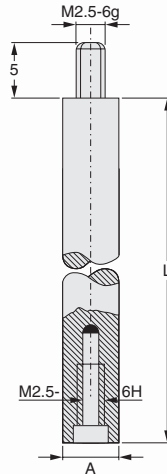

Item No.	Length mm	Price HRK
Extensions with A = ø 5 mm:		
852.465	10	
852.466	15	
852.467	20	
852.468	25	
852.469	30	
852.470	35	
852.471	40	
852.472	45	
852.473	50	
852.474	55	
852.475	60	
852.476	65	
852.477	70	
852.478	75	
852.479	80	
852.480	85	
852.481	90	
852.482	95	
852.483	100	

Adapters for inserts

Adapter for attaching other inserts to dial indicators and probes with an interchangeable insert with thread M2.5.

Item No.	External/internal thread	Price HRK
960.276	M2.5/M2	

MedioTehna

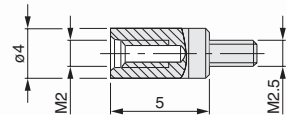

Käfer long angular heads for dial indicators

- Clamping shaft: ø 8 mm.
- Extensions stem: ø 8 mm.
- Thread for inserts and extensions: M2.5.
- Max. probe travel: 4 mm.
- One extension and extra insert are needed for the angular head to function.

Please see the dial indicator accessories section for these inserts.



NEW



Item No.	Description	Price HRK
Long angular heads:		
851.019	Long angular head 90°	
851.020	Long angular head 45°	
851.021	Long angular head 0°	
Extensions:		
851.022	Extension 15 mm	
851.023	Extension 25 mm	
851.024	Extension 50 mm	
851.025	Extension 75 mm	
851.026	Extension 100 mm	

Depth measuring bases for dial indicators

Bases which make dial indicators and probes suitable for depth measurements.

- Clamping shaft: 8H7.

Item No.	Measuring face l x w/mm	Price HRK
907.153	63 x 17	
907.165	101.5 x 17	
With V-shaped measuring face:		
906.644	66 x 16	
With cylindrical measuring face:		
907.179	101.5 x R10.9	

Bridges

A number of standard bridges have been developed for arithmetic indicators to provide several convenient measuring solutions. The accuracy depends on the radius and form deviation of the workpiece. Custom-made bridges are also possible.

Item No.	Description	Price HRK
131.047	Bridge, $r = 15 - 80$ mm	
131.040	Bridge, $r = 40 - 210$ mm	
131.043	Bridge, $r > 40$ mm	
131.044	Bridge, $r > 120$ mm	
131.045	Bridge, $r > 420$ mm	
131.046	Bridge, $r > 1000$ mm	
131.042	Groove gauge 2 - 23 mm	

Clamping bush



Item No.	Description	Price HRK
780.398	Clamping bush VKE	
780.397	Clamping screw VKD	

Swivel-type probe

Swivel-type probe for dial indicators with M2.5 thread. The probe can be oriented over 180°. Equipped with a steel ball probe $\phi 3$ mm.

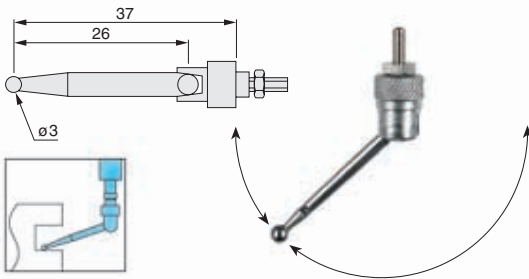

Item No.	Description	Price HRK
900.391	Swivel-type probe	

Angle probe and special probe

Probes e.g. for checks and alignments of bores on lathes.

- Probe measuring range: 10 mm.
- Measuring depth: 30 mm (856.149) or 60 mm (856.150).
- Clamping stem: $\phi 8$ mm.
- Clamping shaft: $\phi 8$ mm.

MedioTehna



Item No.	Description	Price HRK
856.149	Angle probe	
856.150	Special probe	

Clamping bush

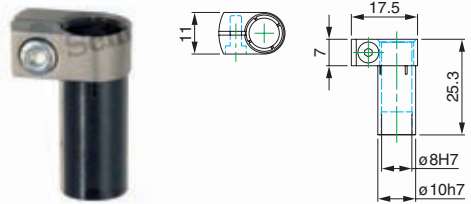

Item No.	Description	Price HRK
906.497	Clamping bush	

Angle probe

Angle probe used for the transmission of the plunger movements up to 10 mm. Suited for dial indicators with a 0.01 mm graduation. Delivery incl. flat insert $\phi 5$ mm.

- Probe measuring range: 10 mm.
- Clamping shaft: $\phi 8$ mm.



Item No.	Description	Price HRK
782.440	Angle probe	

Probe holder

Probe holder for for surfacemounting.

- Clamping shaft: $\phi 8$ mm.
- For attaching with M4 bolts.
- Material: anodized aluminum.

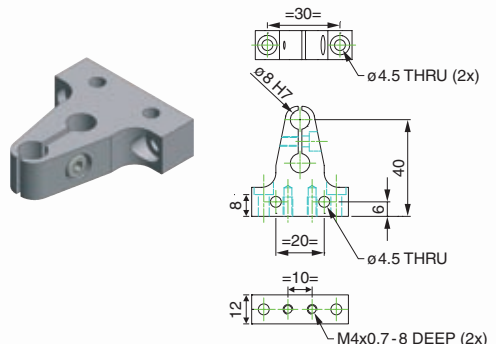

Item No.	Description	Price HRK
993.054	Probe holder	

Peacock dial indicator tester

For checking the accuracy of dial indicators, lever-type dial test indicators and gauges.

- Measuring range: 20 mm (max. spindle thread pitch: 25 mm).
- Graduation: 0.001 mm.
- Accuracy: ± 0.002 mm.
- Several mounting possibilities: vertical intake $\varnothing 8$ mm, horizontal intake $\varnothing 6$ mm.
- Please see the dial test indicator accessories section for other mounting possibilities.
- Provided with mirror for dials facing upward.
- Type NB.
- Delivery in an aluminum carrying case with a manufacturer measuring report.

MedioTehna

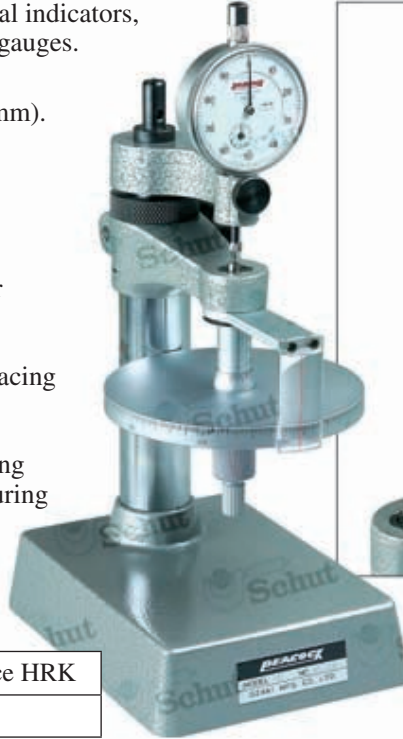

Item No.	Description	Price HRK
855.620	Dial indicator tester	

Dial indicator backs

Dial indicators are by default delivered with either a flat back or a back with lug. For many dial indicators alternative back plates are available, which considerably increases the flexibility for mounting the dial indicators.

The many possible combinations make it impossible to specify them all. The given selection is an impression of the possibilities.



With lug in the middle



With threaded bush



With shifted lug



With adjustable fixture



With magnet



With fixing shank



Flat back

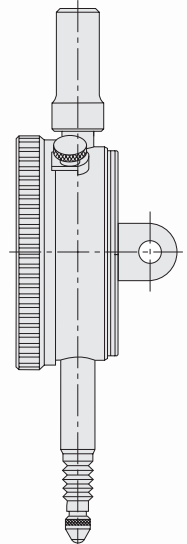

Lever-type dial test indicators

- Measuring range: up to 0.8 mm.
- Graduation: 0.01 or 0.002 mm.
- With dovetail joint and clamping stems $\phi 6$ and $\phi 8$ mm.
- Dial diameter: 40 mm.
- Rotatable dial.
- Stylus tip: $\phi 2$ mm.
- Insert thread: M1.8.
- Delivery with a manufacturer measuring report.



907.941

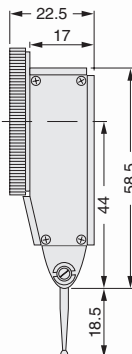

907.942

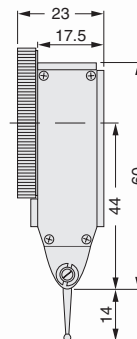

MedioTehna



909.114/115



906.663/664



Clamping stem $\phi 6/\phi 8$ mm.

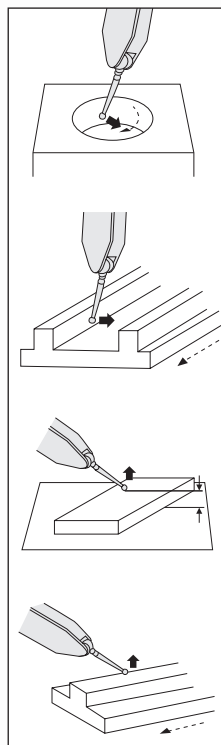

Item No.	Measuring range/mm	Graduation mm	Scale numbering	Insert length/mm	Price HRK
907.941	0.8	0.01	0-40-0	19	
907.942	0.2	0.002	0-100-0	13	

Options:
 909.114 Steel spare stylus tip for 907.941
 909.115 Steel spare stylus tip for 907.942
 906.663 Ruby spare stylus tip for 907.941
 906.664 Ruby spare stylus tip for 907.942



Peacock lever-type dial test indicators

- Measuring range: up to 1 mm.
- Graduation: 0.01, 0.002 or 0.001 mm.
- With dovetail joint and clamping stem $\phi 6$ mm.
- Measuring force: <0.3 N (except 855.610: 0.05 N).
- Dial diameter: $\phi 35$ mm.
- Tungsten carbide stylus tip: $\phi 2$ mm.
- Insert thread: M1.7.
- Delivery in a plastic case with a manufacturer measuring report.

Inserts

Item No.	Ball ϕ /mm	Price HRK
For 855.601/605/610:		
859.016 ¹	2	
859.152 ¹	1	
859.151 ¹	0.8	
859.290 ¹	0.5	
859.576 ²	2	
For 855.602:		
859.126 ¹	2	
859.291 ¹	1	
859.292 ¹	0.8	
859.293 ¹	0.5	
859.577 ²	2	
For 855.603/606:		
859.200 ¹	2	
859.294 ¹	1	
859.295 ¹	0.8	
859.296 ¹	0.5	
859.578 ²	2	
For 855.612:		
859.571 ¹	2	
859.572 ¹	1	
859.573 ¹	0.8	
859.574 ¹	0.5	
859.575 ²	2	
For 855.604:		
859.259 ¹	2	
859.297 ¹	1	
859.298 ¹	0.8	
859.299 ¹	0.5	
859.579 ²	2	
For 855.611:		
859.464 ¹	2	
859.465 ¹	1	
859.466 ¹	0.8	
859.467 ¹	0.5	
859.580 ²	2	

¹ Tungsten carbide.

² Ruby.



Item No.	Measuring range/mm	Max. hysteresis mm	Accuracy mm	Graduation mm	Scale numbering	Insert	Total insert length (TL/EL)/mm	Price HRK
Horizontal:								
855.601	0.5	0.005	± 0.007	0.01	0-25-0	859.016	21.3 /17.74	
855.602	1	0.006	± 0.011	0.01	0-50-0	859.126	42.8 /39.00	
855.603	0.28	0.004	± 0.005	0.002	0-140-0	859.200	17.94/14.33	
855.612	0.28	0.004	± 0.005	0.002	0-140-0	859.571	23.47/19.61	
855.604	0.14	0.004	± 0.005	0.001	0-70-0	859.259	11.7 / 8.13	
855.610	0.5	0.005	± 0.007	0.01	0-25-0	859.016	21.3 /17.74	
855.611	0.8	0.005	± 0.010	0.01	0-40-0	859.464	22.4 /19.24	
Perpendicular:								
855.605	0.5	0.005	± 0.007	0.01	0-25-0	859.016	21.3 /17.74	
855.606	0.28	0.004	± 0.005	0.002	0-140-0	859.200	17.94/14.33	

Accessories dial indicators/dial test indicators

Item No.	Description	Price HRK
909.433	Centering support $\varnothing 8 \times 25$ mm, holder $\varnothing 4$ mm	
909.434	Rectangular fixing shaft $12 \times 6 \times 76$ mm, holder $\varnothing 4/\varnothing 8$ mm and dovetail clamp	
909.435	Rectangular fixing shaft $12 \times 6 \times 76$ mm, holder $\varnothing 6/\varnothing 8$ mm and dovetail clamp	
909.436	Rectangular fixing shaft $9 \times 9 \times 76$ mm, holder $\varnothing 4/\varnothing 8$ mm and dovetail clamp	
909.437	Rectangular fixing shaft $9 \times 9 \times 76$ mm, holder $\varnothing 6/\varnothing 8$ mm and dovetail clamp	
909.438	Round, swivelling fixing shaft $\varnothing 6 \times 70$ mm, holder with dovetail clamp	
909.439	Round, swivelling fixing shaft $\varnothing 8 \times 70$ mm, holder with dovetail clamp	



Reducer



837.190

MedioTehna

Item No.	Diameter	Price HRK
781.819	$\varnothing 8 \rightarrow 4$ mm	
837.190	$\varnothing 8 \rightarrow 6$ mm	

Center-accessory

Small magnetic dial indicator stand which, in combination with a lever, could also be used as center-accessory to align bores in workpieces. For use in combination with a machine center.

- Permanent magnet $\varnothing 25$ mm.
- Universal pivot with dovetail clamp.
- Fine adjustment.
- Cylindrical support $\varnothing 10$ mm for insert in the collet chuck of a machine center.



Item No.	Description	Price HRK
910.341	Center-accessory	
960.490	Cylindrical support	

Centering device

Convenient tool to find and set up the position of a workpiece on vertical and horizontal machines. It can also be used to determine the position of a workpiece when the spindle is rotated by hand or automatic. Easy read-out from stationary dial indicator. Instrument with compact dimensions.

- Max. range of use: 300 mm.
- Scale read-out per rotation: 0-3 mm.
- Graduation: 0.01 mm.
- Centering inside and outside with various probes.
- 3 straight and 3 bended probes included.
- Center feeler included.
- Spindle rotating speed max. 700 rpm.
- Compact dimensions (length basic instrument: 140 mm).
- For horizontal and vertical use suitable.
- Clamping stem: \varnothing 10 mm.
- Delivery in a plastic carrying case.

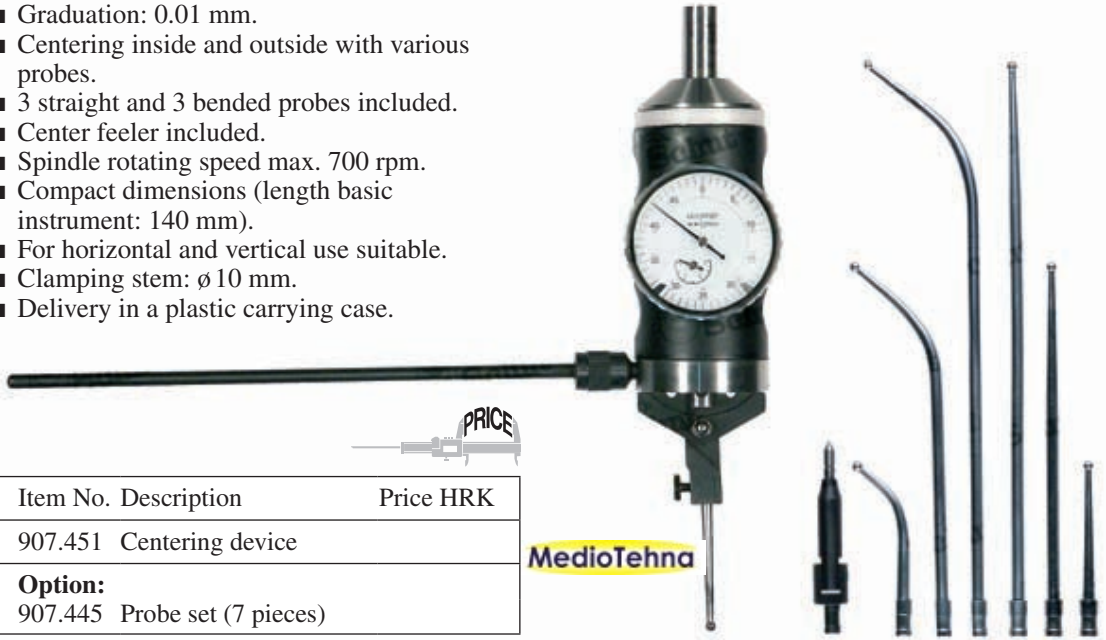

Item No.	Description	Price HRK
907.451	Centering device	
Option:		
907.445	Probe set (7 pieces)	

Edge finders

Edge finders for both stationary and rotating use. As soon as the workpiece is touched by the ballprobe the all around visible LED will light up due to galvanic contact. The ballprobe is held in place by a spring. When the pressure on the tip becomes too large the ball will flip away sideways. The edge finders are also available with additional sound signal for extra working comfort.

- Concentricity: <0.01 mm.
- Diameter ballprobe: 10 mm.
- Power supply:
907.456/460: 2 batteries type V357,
907.454/458: 1 battery type 23A.

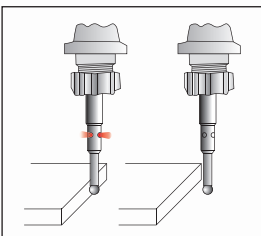

Item No.	Clamping stem \varnothing /mm	Length mm	Price HRK
907.454	20	162	
907.456	20	100	
With sound signal:			
907.458	20	162	
907.460	20	100	
Options:			
836.535	Spare battery type V357 (2 needed)		
497.931	Spare battery type 23A		

3D probes for centering and measuring

For easy and with high accurate setting the reference point of workpiece in all three axes (X, Y and Z), vertically and horizontally.

- Measuring range: max. ± 2 mm (rupture point in probe).
- Analog: graduation 0.01 mm, digital: resolution 0.001 mm.
- Clamping stem: $\varnothing 20$ mm.
- Insert length 27 mm, stylus tip $\varnothing 4$ mm (insert length 69 mm and diameter 8 mm optional).
- mm/inch conversion (only 853.822).
- Digit height: 8.5 mm (only 853.822).
- Isolation between insert and insert thread; for use on all machining centres and EDM machines.
- Insert thread: M3.
- Protection: analog: IP67, digital: IP64.
- Delivery with a manufacturer measuring report.

MedioTehna

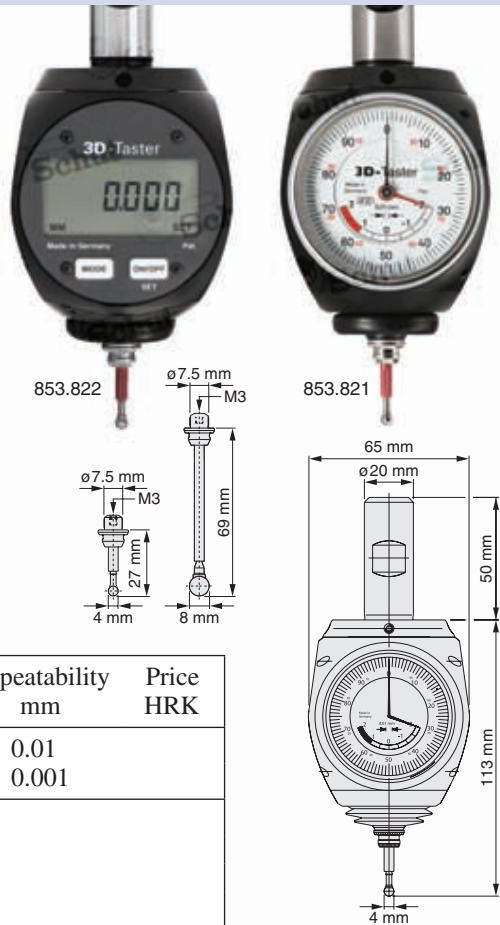

Item No.	Description	Accuracy mm	Repeatability mm	Price HRK
853.821	Analog 3D probe	±0.01	0.01	
853.822	Digital 3D probe	±0.005	0.001	
Options:				
495.157	Spare battery type CR2032			
853.823	Spare insert 27 mm, tip diameter 4 mm			
853.824	Spare insert 69 mm, tip diameter 8 mm			

Edge finders

Rotating edge finders for accurate edge location.

- Resolution: 0.005 mm.
- Repeatability: 0.005 mm.
- Range of use: 400 - 600 rpm.
- Hardness TiN measuring face: 2200 HV.

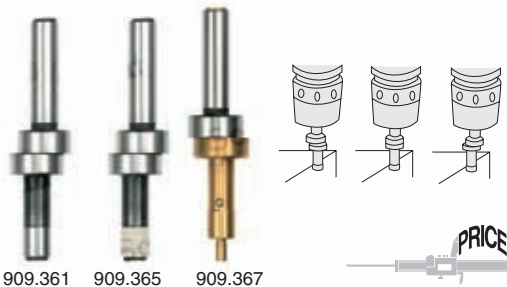

Item No.	Clamping stem \varnothing /mm	Probe \varnothing /mm	Material (measuring face)	Price HRK
909.360	8	10	steel	
909.361	10	10	steel	
909.362	8	4 and 10	steel	
909.363	10	4 and 10	steel	
909.364	6	6	steel	
909.365	10	10	steel + ceramic	
909.366	10	10	steel + TiN	
909.367	10	4 and 10	steel + TiN	
Options:				
909.368	Spring for 909.360/362			
909.369	Spring for 909.364			
909.359	Spring for 909.365			
909.349	Spring for 909.361/363/366/367			

Z-axis setting gauge

For easy pre-setting of the Z-axis with tools, whether or not in combination with parallel blocks to set a specific height. As soon as the tool touches the setting gauge (with floating top) the built-in red LED illumination will light up. After this the axis will move in opposite direction until the lamp turns off, this is the turning point, and so the setting gauge, to determine the accuracy.

- Repeatability: 0.01 mm.
- With magnetic base.
- Galvanic contact principle.



- Dimensions:
ø54 x 50 mm (precise height to determine with external measuring instrument).
- Weight: 450 g.
- Power supply:
2 batteries type V389.



Item No.	Description	Price HRK
908.804	Z-axis setting gauge	
Option:		
498.823	Spare battery type V389 (2 needed)	

Digital Z-axis setting gauge

For easy pre-setting of the Z-axis with tools, whether or not in combination with parallel blocks to set a specific height.

- Graduation: 0.01 mm.
- Repeatability: 0.01 mm.
- With magnetic base.
- mm/inch conversion.



MedioTehna

- Automatic switch-off.
- Height: 50 mm (precise height to determine with external measuring instrument).
- Weight: 377 g.
- Power supply: 1 battery type V357.
- Delivery with reference pin for insert in tool holder.

Item No.	Description	Price HRK
910.169	Z-axis setting gauge	
Option:		
836.535	Spare battery type V357	

Z-axis setting gauge

For easy pre-setting of the Z-axis with tools, whether or not in combination with parallel blocks to set a specific height.

- Graduation: 0.01 mm.
- Repeatability: 0.02 mm.
- With magnetic base.
- Diameter dial indicator: ø35 mm.



- Height: 50 mm (precise height to determine with external measuring instrument).
- Weight: 1013 g.
- Delivery with reference pin for insert in tool holder.



Item No.	Description	Price HRK
909.460	Z-axis setting gauge	

Tool presetters

Cost effective solution as an additional setup directly next to your machine, for setting up and accurately measuring length and diameter of milling, turning and drilling tools. Increase your machine up-time through rapid manual movement with release/hook-up button and fine adjustment using the hand wheel (only 837.928/916).

- Resolution: 0.01 mm.
- mm/inch conversion.
- RS232C data output.
- On/off switch.
- Preset.
- Interchangeable rotating chuck.
- Delivery incl. rotating chuck ISO 40.
- Conforms to factory standard.
- Delivery with a manufacturer measuring report.
- Power supply: 2 batteries type CR2032.
- Various models with extended functionality available on request.

MedioTehna



Options

Item No.	Type	Price HRK
Rotating chuck:		
837.930	ISO 30	
837.917	ISO 40	
837.931	ISO 45	
837.932	ISO 50	
837.933	HSK 40	
837.934	HSK 50	
837.935	HSK 63	
837.936	VDI 40	
837.937	DLBH-SKF 63	
ISO reductions:		
837.938	50-45	
837.939	50-40	
837.940	50-30	
837.941	40-30	
837.942	50HSK40	
837.943	50HSK50	
837.944	50HSK63	
Spare battery:		
495.157	CR2032	

Item No.	Measuring range/mm X-axis Z-axis	Dimensions l x w x h/mm	Weight kg	Price HRK
Without fine adjustment:				
837.929	160 (ø 320) 320	420 x 150 x 755	20	
With hand wheel for fine adjustment:				
837.928	160 (ø 320) 320	584 x 150 x 520	25	
837.916	260 (ø 520) 520	684 x 150 x 848	30	

Electronic probe and read-out unit

Inductive, absolute electronic probe for precision measurements. The measured value is displayed both digitally and digital-analogue. The 2-axes model of the read-out unit has an addition function for the probes.

Electronic probe

- Measuring range: ± 1 mm.
- Resolution: $0.1 \mu\text{m}$.
- Accuracy: $\pm 3.5 \mu\text{m}$.
- Measuring force: 1.2 N.
- Clamping stem: $\varnothing 8$ mm.



Digital read-out units

- Measuring range: 2 mm.
- Resolution: $0.1 \mu\text{m}$.
- Digital-analogue graduation: 100/20/10/2/1/0.2/0.1 μm .
Range: $\pm 20\times$ graduation.
- $\mu\text{m}/\text{inch}$ conversion.
- ABS/INC switchable.
- On/off switch.
- Reset/preset.
- Hold function.
- Addition function: $\pm A \pm B$ (only 907.858).
- Adjustable tolerance limits.
- Power supply: 3 batteries type AA.



907.791



907.790



Item No.	Description	Price HRK
907.790	Electronic probe	
907.791	Read-out unit, 1 axis	
907.858	Read-out unit, 2 axes	
Option:		
495.111	Spare battery type AA (3 needed)	

Display-unit for measuring probes

Robust, splashproof display-unit, machined from a solid aluminum block, that can be employed in both simple and complex measurements. Both analog and digital display of up to 32 dimensions simultaneously, with (green, yellow, red) tolerance assessment per dimension. The display-unit is universally applicable due to its compatibility with many instrument brands, and powerful due to its ability to display up to 32 dimensions at the same time and it's trigonometrical-, statistical and PLC functions. The device is very suitable for efficient quality control without the need for a PC in the workspace.

- 7" color touch screen.
- Up to 99 probes can be connected.
- Display up to 32 dimensions.
- Store up to 128 measurement configurations.
- Memory for max, min, difference, average.
- Dynamic or static measurements.
- mm/inch conversion.
- ABS/INC switchable.
- Hold function.
- Statistical functions, e.g. histograms with Gauss curve, Pareto graph, q-q plot, CM, CMK.
- Configuration protection by password.
- Multilingual software, e.g. English, French, German, Dutch.
- Works with instruments such as TESA, Mitutoyo, Magnescale and more.

- Dimensions: 200 x 151.6 x 143 mm.
- Storage of measuring data.
- Delivery with AC adapter.
- Modules can be mounted on a standard DIN rail.

Connections:

- Footswitch.
- USB port for USB stick.
- Ethernet (ASCII/Modbus TCP).
- RS232 (ASCII/Modbus RTU).
- M-Bus input for probes.



Item No.	Type/description	Price HRK
857.880	Display-unit	
Options:		
857.806	Module for 4 Digimatic instruments	
857.881	Module for 8 TESA probes	
857.883	Module for 4 Magnescale probes	
857.884*	Power module	
348.287	Connecting cable display-unit/probe module (3 m)	



* For applications using more than 30 analog TESA probes, or 4 Magnescale probes on 1 display-unit.

Modules for various instruments from other brands available on request.

MedioTehna

Analog probes

- Half-bridge probes.
- Measuring range: ± 0.25 to ± 10 mm.
- Repeatability: $< 0.15 \mu\text{m}$.
- Non-linearity: $< 0.3\%$.
- All non-pneumatic probes with cable guide have a cable exit square to probe body.

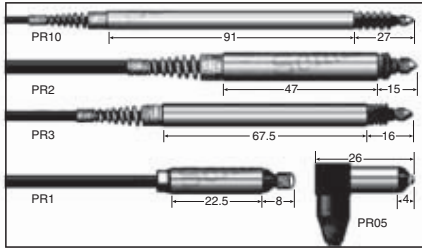

MedioTehna



Feather Touch probes

Probes with a very small measuring force to measure sensitive materials like electronic components and thin-walled glass products.

Item No.	Type	Measuring range/mm	Max. travel mm	Measuring force/N	Total length mm	Price HRK
Feather Touch probes with a small measuring force and tungsten carbide probe tip:						
360.964	PRFC2P	± 1	3	0.18/1.10 ¹	75.6	
360.965	PRFC5P	± 2.5	6	0.18/1.10 ¹	99.6	
360.966	PRFC10P	± 5	11	0.18/1.10 ¹	130.1	
360.962	PRFC5S	± 2.5	6	0.30	96.3	
360.963	PRFC10S	± 5	11	0.30	118.3	
Option:						
360.967	Nylon probe tip					
Probes with regular measuring force³:						
360.916	PR05	± 0.25	0.6	0.70	26	
360.917	PR1	± 0.5	1.5	0.70	30.5	
360.911	PR2	± 1	2.5	0.70	62	
360.912	PR2P	± 1	3.5	0.80 ²	67	
360.926	PR101P	± 1	11	0.70 ²	117.5	
360.910	PR10	± 5	11	0.70	83.5	
360.909	PR10P	± 5	11	0.70 ²	87.5	
360.905	PR20	± 10	21	0.70	96.5	
360.904	PR20P	± 10	21	0.70 ²	118	

Measuring range, measuring force and extended probe length defined at electrical zero.

P = Pneumatic, probe is operated by air pressure.

¹ Air pressure 0.3 bar (nominal) / Air pressure 1.0 bar (nominal).

² Air pressure 0.4 bar (nominal).

³ Protection: IP65.

Digital absolute measuring probes

The measuring probe, which replaces the conventional analog probe more and more. These probes, that combine the advantages of the analog and not absolute digital models, are a solution to measuring systems which have to process the measuring data in a PC.

Configuration:

- Probe (clamping shaft 8h6) fixed via a cable (2 m) to the electronics module.
- T-CON connector.
- Cable (standard up to 5 m).
- Supply module (necessary with RS232C module, and with more than five probes on a board or module).
- RS232C/USB module or digital absolute measuring probe board (supports up to 100 probes).

Technical data:

- A maximum of 240 measurements per second.
- Repeatability: <math>< 0.15 \mu\text{m}</math>.
- Accuracy:
 - DP-2S, DP-2P: $\pm 1 + 0.05 \%K$,
 - DP-5S, DP-5P: $\pm 1 + 0.05 \%K$,
 - DP-10S, DP-10P: $\pm 1 + 0.06 \%K$,
 in which K is the displacement (in mm).
- Protection: IP65.
- Measuring force S-types: 0.7 N, P-types (at 0.4 bar pressure): 0.8 N.
- Also available on request as low measuring force *Feather Touch* models.

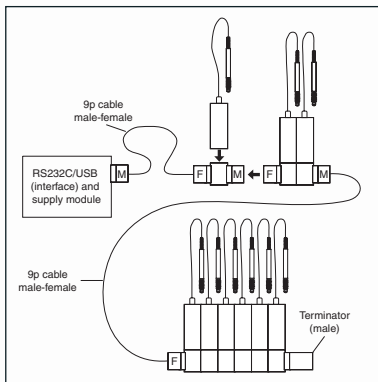

MedioTehna

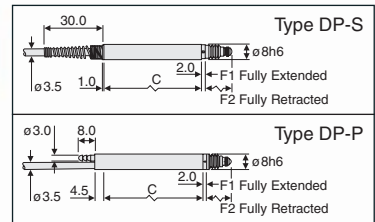

Item No.	Type	Measuring range/mm	Max. travel/mm	Probe movement	Dimensions/mm			Price HRK
					C	F1	F2	
360.880	DP-2S	± 1	3	spring push	46	13.9	10.9	
360.881	DP-5S	± 2.5	6	spring push	65	17.4	11.4	
360.882	DP-10S	± 5	11	spring push	89	25.4	14.4	
360.883	DP-2P	± 1	3	pneumatic push	52	13.9	10.9	
360.884	DP-5P	± 2.5	6	pneumatic push	71	17.4	11.4	
360.885	DP-10P	± 5	11	pneumatic push	96	25.4	14.4	
360.852	T-CON connector (has to be ordered separately per probe)							
360.835	Supply module (required when using a RS232C module and when connecting more than five probes to a board or module, excl. power cable)							
420.300	Power cable							
360.890	Digiprobe PCI board Orbit 3							
360.888	Digiprobe USB module Orbit 3							
348.287	Cable 3 m between electronic module and board/module							
348.288	Cable 5 m between electronic module and board/module							

Clamping bush



Item No.	Description	Price HRK
780.398	Clamping bush VKE	
780.397	Clamping screw VKD	

Clamping bush

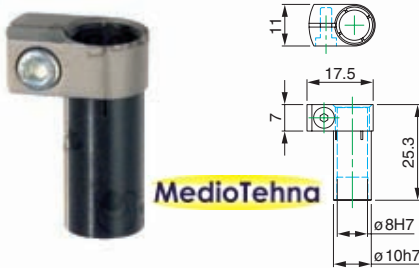

Item No.	Description	Price HRK
906.497	Clamping bush	

Probe holder

Probe holder for for surfacemounting.

- Clamping shaft: $\phi 8$ mm.
- For attaching with M4 bolts.
- Material: anodized aluminum.

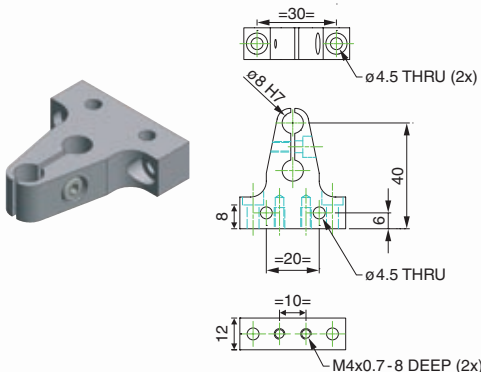

Item No.	Description	Price HRK
993.054	Probe holder	

Inserts

Many inserts with thread M2.5 are available. See the dial indicator accessories section for more information.



Retraction levers

Universal retraction levers, bottom or top mounted, compatible with a wide range of probes and dial indicators. You can find various models in the dial indicator accessories section.

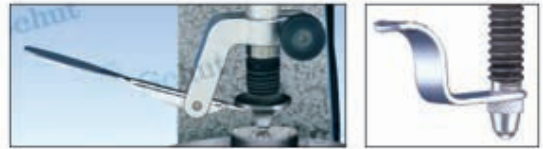

Retraction device DZ801

Pneumatic retraction device for Magnescale and TESA gauges, with 1 meter hose and air tube connector.



Item No.	Description	Price HRK
344.465	Retraction device	

Clamp collar with dovetail

For clamping TESA GT31 probes and e.g. lever type dial indicators.

- Fastening points: $\phi 5.6$ mm, $\phi 9.5$ mm and with dovetail.

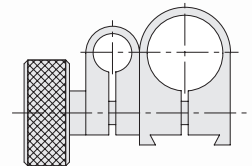

Item No.	Description	Price HRK
780.208	Clamp collar	

Stands / Bench centers / Surface plates

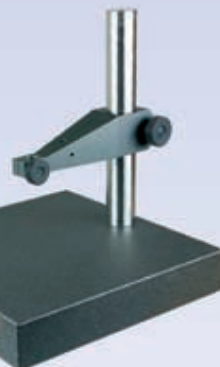

Flatness tolerances according DIN 876

Class	Flatness t_f (μm)
00	$2 + L/500$
0	$4 + L/250$
1	$10 + L/100$
2	$20 + L/50$
3	$40 + L/25$

L = length
in mm



Dial indicator stands

- With dovetail joint (only 908.958/972).
- With fine adjustment (except 908.958/974).
- On/off switchable magnetic base with V-groove, except 908.973 (*flexform* base with locking mechanism and permanent magnetic force) and 908.974 (flat on/off switchable magnetic base).
- Various bases available.



Item No.	Clamping shaft/mm	Column mm	Arm mm	Desc. of base	Dimensions l x w x h/mm	Magn. force ¹ /N	Thread of base	Price HRK
908.950	ø4/ø8	ø12x176	ø10x150	V-groove	58x50x55	600 ^(S)	M8 x 1.25	
908.951	ø4/ø8	ø12x176	ø10x150	V-groove	60x50x55	800 ^(S)	M8 x 1.25	
908.952	ø6/ø8	ø20x350	2 arms: ø12x220 ø10x150	V-groove	74x50x55	1000 ^(S)	M10x1.5	
908.958	ø8	ø8x130	ø8x130	V-groove	36x30x35	400 ^(S)	M5 x 0.8	
908.972	ø8	ø12x176	ø10x210	V-groove	60x50x55	800 ^(S)	M8 x 1.25	
908.973	ø4/ø8	ø12x176	ø10x150	<i>flexform</i>	75x46x55	400 ^(P)	M8 x 1.25	
908.974	ø6	ø7x50		flat	30x30x30	170 ^(S)	M5 x 0.8	
908.946 ²	ø8	ø12x190	ø10x160	V-groove	54x40x47	800 ^(S)	M8 x 1.25	

¹ S = switchable magnet; P = permanent magnetic force.

² V-groove on 3 sides.

PRICE

Dial indicator stands

- Clamping shaft $\varnothing 8$ mm for dial indicators and probes (except 910.341: $\varnothing 6$ mm), and dovetail joint for lever-type dial test indicators (908.957 without dovetail joint).
- With fine adjustment (except 908.962/964/957).
- Arm with mechanical central clamping device (908.954/955: hydraulic).
- On/off switchable magnetic base with V-groove, except 908.964 and 910.341 (permanent magnetic force), 908.961 (vacuum base) and 908.975 (*flexform* base with locking mechanism and permanent magnetic force).
- Various bases available.



Item No.	Clamping	Arm length ¹ /mm	Description of base	Dimensions l x w x h/mm	Magnetic force ² /N	Thread of base	Price HRK
908.953	mechanical	320	V-groove	58 x 50 x 55	600 ^(S)	M8 x 1.25	
908.959	mechanical	340	V-groove	60 x 50 x 55	800 ^(S)	M8 x 1.25	
908.960	mechanical	285	V-groove	60 x 50 x 55	800 ^(S)	M8 x 1.25	
908.954	hydraulic	380	V-groove	58 x 50 x 55	600 ^(S)	M8 x 1.25	
908.955	hydraulic	380	V-groove	60 x 50 x 55	800 ^(S)	M8 x 1.25	
908.962	mechanical	150	V-groove	36 x 30 x 35	400 ^(S)	M5 x 0.8	
908.964	mechanical	65	cylinder	$\varnothing 30 \times 25$	170 ^(P)	M8 x 1.25	
910.341	mechanical	60	cylinder	$\varnothing 25 \times 25$	100 ^(P)	M5 x 0.8	
908.975	mechanical	280	<i>flexform</i>	75 x 46 x 55	400 ^(P)	M8 x 1.25	
908.961	mechanical	280	vacuum base	$\varnothing 90 \times 25$		M8 x 1.25	
908.956	mechanical	360	V-groove	60 x 50 x 55	800 ^(S)	M8 x 1.25	
908.957	mechanical	320	V-groove	60 x 50 x 55	800 ^(S)	M8 x 1.25	

¹ The outstretched length between base and clamping shaft.

² S=switchable magnet; P=permanent magnetic force.

Bases for dial indicator stands

A solid base is essential for accurate measurements. The dial indicator arms can be mounted on a strong magnetic or vacuum base.

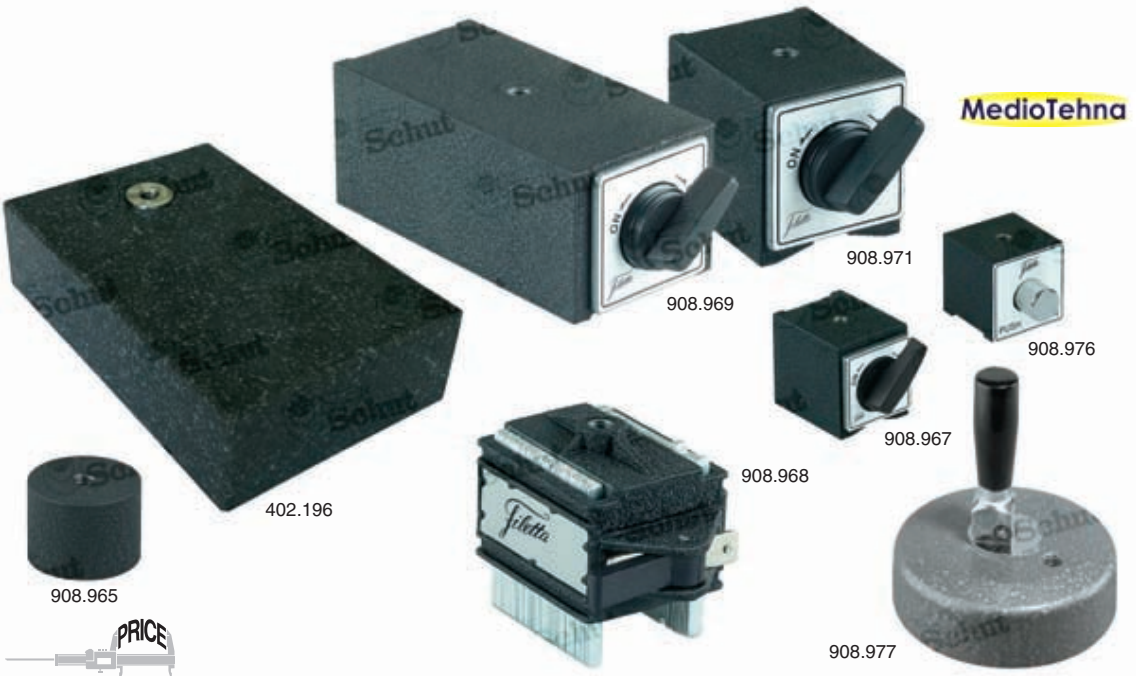

Item No.	Description	Dimensions l x w x h/mm	Magnetic force*/N	Thread	Price HRK
908.971	V-groove	60 x 50 x 55	800 ^(S)	M8 x 1.25	
908.970	V-groove	74 x 50 x 55	1000 ^(S)	M8 x 1.25	
908.969	flat base	118 x 50 x 52	1500 ^(S)	M8 x 1.25	
908.967	V-groove	36 x 30 x 35	400 ^(S)	M5 x 0.8	
908.976	flat base	30 x 30 x 30	170 ^(S)	M5 x 0.8	
908.968	flexform	75 x 46 x 55	400 ^(P)	M8 x 1.25	
908.965	cylinder	∅40 x 30	300 ^(P)	M8 x 1.25	
908.977	vacuum base	∅90 x 25		M8 x 1.25	
402.196	granite base	150 x 100 x 40		M8 x 1.25	

* S=switchable magnet; P=permanent magnetic force.

Fixing clamps for dial indicator stands

Item No.	Fixing clamp ∅/mm		Price HRK
	d1	d2	
907.443	10	8/4	
907.442	10	8/6	
906.398	12	8/6	
907.440	12	10	
907.444	14	8/6	
906.399	20	12	
907.441	20	14	



Magnetic dial indicator stands

Solid dial indicator stands with on/off switchable magnetic base.

- Clamping shaft: $\varnothing 6$ and $\varnothing 8$ mm.
- Magnetic base with V-groove.
- Magnetic face at the back (except 855.707).



Item No.	Dimensions base l x w x h/mm	Magnetic force/N	Column mm	Arm mm	Thread of base	Price HRK
855.701	58 x 50 x 55	800	$\varnothing 12 \times 176$	$\varnothing 10 \times 150$	M8	
855.705	73 x 50 x 55	1000	$\varnothing 20 \times 178$	$\varnothing 14 \times 165$	M8	
855.707	117 x 50 x 55	1300	$\varnothing 20 \times 365$	$\varnothing 14 \times 200$	M20	

Magnetic dial indicator stands

Solid dial indicator stands with on/off switchable magnetic base.

- Clamping shaft: $\varnothing 6$ and $\varnothing 8$ mm.
- Screw thread base: M8.
- Magnetic base with V-groove.
- Magnetic face at the back.

MedioTehna



Item No.	Clamping	Dimensions base l x w x h/mm	Magnetic force/N	Arm length* mm	Price HRK
855.706	hydraulic	73 x 50 x 55	1000	335	
855.710	mechanical	58 x 50 x 55	800	335	

* The outstretched length between base and clamping shaft.

Flexible hoses for coolant with magnetic base

- Suitable for cooling on machines in places of the workpiece that are difficult to reach.
- With 1, 2 or 3 flexible hoses.
- Special coupling for supply hose $\varnothing 8.5$ mm.

Support with magnetic base

- On/off switchable magnetic base with V-groove.
- Magnetic force: 588 N.
- Separate on/off switch for every flexible hose.
- Dimensions base $l \times w \times h$:
 906.213: 62 x 51 x 73 mm,
 906.214: 62 x 51 x 74 mm,
 906.215: 69 x 51 x 75 mm.

With round magnetic base

- Magnetic base $\varnothing 35$ mm, with high adhesive force.
- Metal protection plate under magnetic base.



Item No.	Number of flexible hoses	Price HRK
Support with magnetic base:		
906.213	1	
906.214	2	
906.215	3	

Item No.	Number of flexible hoses	Price HRK
With round magnetic base:		
906.216	1	
906.217	2	
906.218	3	

LED lamp on magnetic stand

- Total length: 215 mm.
- Magnetic force: 120 N.
- Power supply: 3 batteries type AAA.



Item No.	Description	Price HRK
909.607	LED lamp on magnetic stand	
Option:		
497.914	Spare battery type AAA (3 needed)	

MedioTehna

Measuring stands

- Clamping shaft: $\varnothing 8$ mm.
- Transverse arm with fine adjustment.
- Arm length: 150 mm.
- Ground base.
- Base with V-groove (only 857.120).



857.120



857.121

Item No.	Column \varnothing /mm	Dimensions base/mm	Effective arm length/mm	Price HRK
857.120	16	65 x 40 x 140	250	
857.121	22	60 x 55 x 250	300	

Measuring stand

- Clamping shaft: $\varnothing 8$ mm.
- Effective arm length: 180 mm.
- Fine adjustment.
- Ground base with V- and T-groove, 250 x 60 x 35 mm.
- Column: $\varnothing 16$ x 295 mm.
- Arm: $\varnothing 16$ x 235 mm.
- Mechanical clamping device.
- Dial indicator not included.

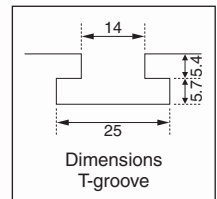

MedioTehna

Item No.	Description	Price HRK
856.720	Measuring stand	

Measuring stands

- Clamping shaft: $\varnothing 8$ mm.
- Transverse arm with fine adjustment.
- Ground base with T-groove.
- Base with V-groove (only 909.376).

MedioTehna



906.219



Item No.	Column mm	Arm mm	Dimensions base/mm	Price HRK
906.219	$\varnothing 14 \times 185$	$\varnothing 12 \times 245$	220 x 60 x 35	
909.376	$\varnothing 16 \times 290$	$\varnothing 16 \times 310$	260 x 60 x 50	

Measuring stand with spindle adjustment

Measuring stand with clear graduation 0.02 mm on the spindle and a hand wheel for easy adjustment of the height setting.

- Clamping shaft: $\varnothing 8$ mm.
- Spindle thread pitch: 2 mm.
- Column: $\varnothing 35$ mm.
- Transverse arm: $\varnothing 20$ mm.
- Granite measuring table: 260 x 150 x 50 mm, measuring face: 250 x 150 mm, flatness according DIN 876/00.
- Total height: 410 mm.
- Max. measuring height: 160 mm.
- Delivery in a wooden box.



Item No.	Description	Price HRK
907.789	Measuring stand	

Measuring stand

Universal measuring stand, also suitable as a control measuring device.

- Clamping shaft $\varnothing 8$ mm and dovetail joint.
- Fine adjustment.
- Granite measuring table: 150 x 100 x 40 mm, flatness: $\leq 10 \mu\text{m}$.
- Base with groove in the center.
- Screw thread base: M8.
- Long, right side face with two mounting bores (thread M5, distance 120 mm).
- Mechanical clamping device.
- Arm length: 300 mm (the outstretched length between base and clamping shaft).
- Delivery in an aluminum carrying case.



Item No.	Description	Price HRK
910.436	Measuring stand	

Measuring stand

- Clamping shaft: $\varnothing 8$ mm.
- Total height: 200 mm.
- Max. measuring height: 90 mm.
- Effective arm length: 80 mm.
- Measuring table: 60 x 68 mm, ground and lapped.
- Dimensions transverse arm: $\varnothing 18 \times 120$ mm.
- Column: $\varnothing 22$ mm.
- Other dial gauge holders are available on request.



MedioTehna



Item No.	Description	Price HRK
857.130	Measuring stand	

Measuring stands

Universal measuring stands with a cast iron, ground measuring table.

- Clamping shaft: $\varnothing 8$ mm (optional available clamp with clamping shaft $\varnothing 28$ mm).
- Fine adjustment: 5 mm (906.506/508/516/518).
- Total height: 250 mm (906.508: 350 mm).
- Max. measuring height: 160 mm (906.508: 260 mm).
- Effective arm length: 68 mm (906.507: max. 105 mm, 906.517/519: max. 95 mm).
- Measuring table: ground, 906.506/507/508: flat anvil/base, 906.516/517: round flat anvil (height anvil: 13.5 mm), 906.518/519: round serrated anvil (height anvil: 13.5 mm).
- Flatness table: $\leq 10 \mu\text{m}$.
- Dimensions transverse arm: $\varnothing 20 \times 150$ mm (906.507/517/519).
- Column: $\varnothing 30 \times 200$ mm (906.508: helical threaded 300 mm with anti drop facility).

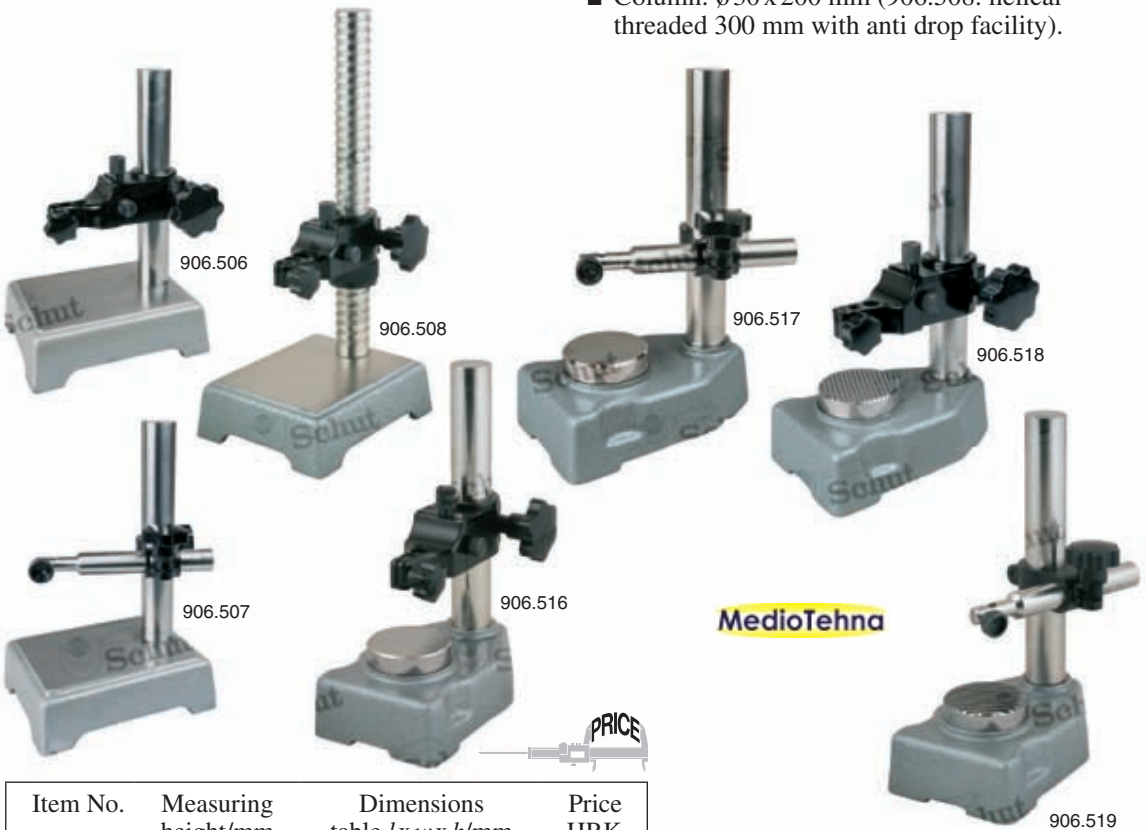

Item No.	Measuring height/mm	Dimensions table l x w x h/mm	Price HRK
906.506	140	140 x 105 x 50	
906.507	160	140 x 105 x 50	
906.508	260	140 x 105 x 50	
906.516	130	$\varnothing 60 \times 65$	
906.517	145	$\varnothing 60 \times 65$	
906.518	130	$\varnothing 60 \times 65$	
906.519	145	$\varnothing 60 \times 65$	
Option:			
999.679	Clamp $\varnothing 28$ mm		



999.679

Measuring stands

Universal measuring stands with a granite measuring table.

- Clamping shaft: $\varnothing 8$ mm (optional available clamp with clamping shaft $\varnothing 28$ mm).
- Fine adjustment: 5 mm (999.680).
- Total height: 240 mm (999.680/681), 355 mm (999.682/683), 370 mm (999.684/685).
- Max. measuring height: 260 mm (999.682/683/684/685).
- Effective arm length: max. 165 mm (999.682/683/684/685), (999.681: max. 105 mm, 999.680: 68 mm).
- Measuring table: granite.
- DIN 876/0.
- Dimensions transverse arm: $\varnothing 20 \times 150$ mm (999.681), $\varnothing 20 \times 210$ mm (999.682/683/684/685).
- Column: $\varnothing 30 \times 200$ mm (999.680/681), $\varnothing 30 \times 300$ mm (999.682/684), $\varnothing 30 \times 300$ mm (999.683/685: helical threaded with anti drop facility).
- Measuring table delivered with a manufacturer measuring report (only 999.684/685).

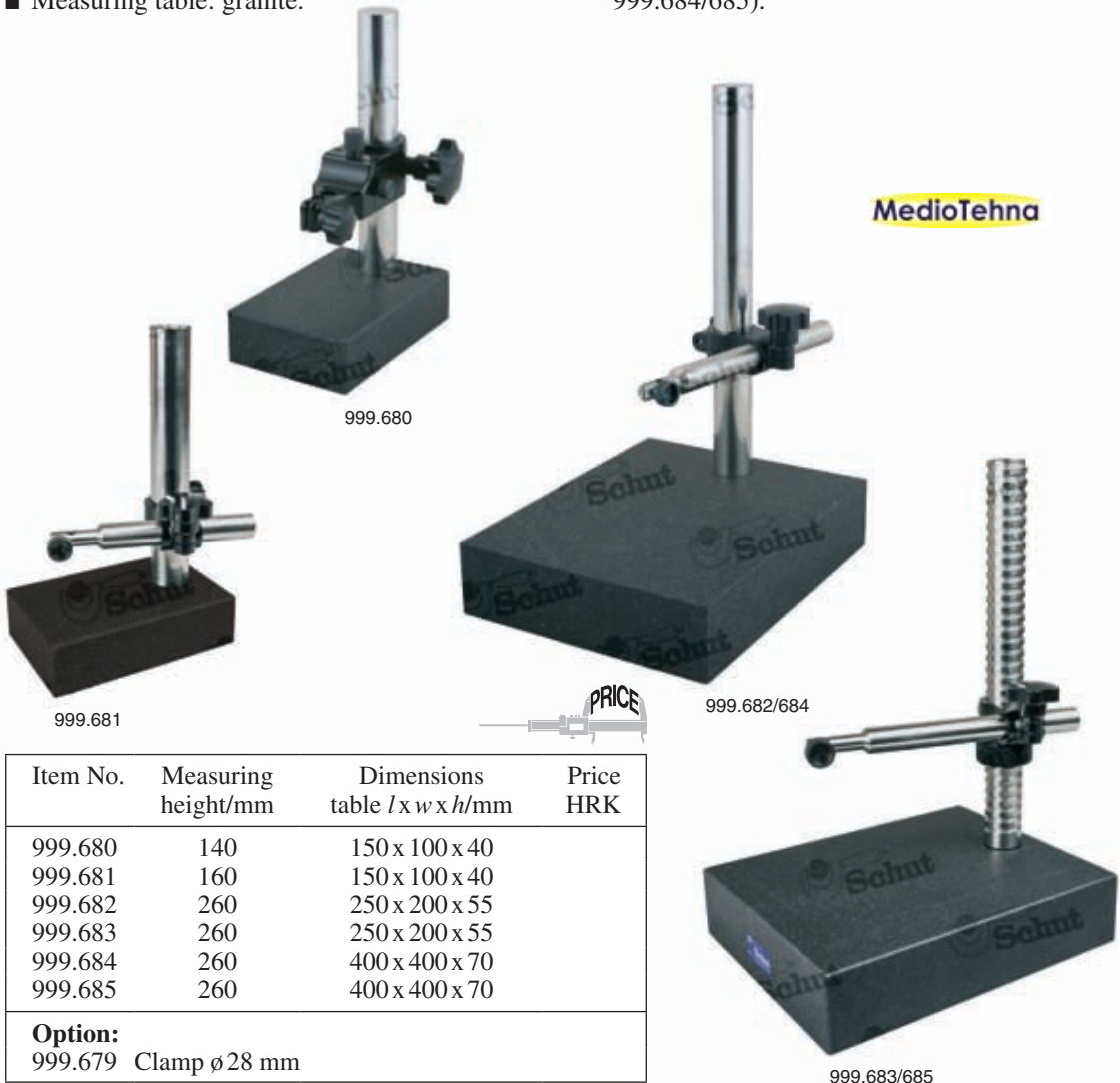

Item No.	Measuring height/mm	Dimensions table l x w x h/mm	Price HRK
999.680	140	150 x 100 x 40	
999.681	160	150 x 100 x 40	
999.682	260	250 x 200 x 55	
999.683	260	250 x 200 x 55	
999.684	260	400 x 400 x 70	
999.685	260	400 x 400 x 70	

Option:
999.679 Clamp $\varnothing 28$ mm

Measuring stands

Measuring stands with a granite base in two models with a competitive price-performance ratio.

- Clamping shaft: \varnothing 8 mm.
- Max. measuring height: 250 mm.
- Anti drop facility.
- Granite table.
- DIN 876/0.
- Own product.

MedioTehna



402.165

Item No.	Measuring height/mm	Flatness table/ μ m	Dimensions table l x w x h/mm	Column \varnothing /mm	Effective arm length/mm	Price HRK
402.165	150	10	150 x 100 x 40	25	62	
402.168	250	10	250 x 200 x 55	35	100	

Measuring stand

Heavy-duty precision stand with alumina ceramic grooved table and plain column.

- Clamping shaft: \varnothing 8 mm.
- Max. measuring height: 135 mm.
- Effective arm length: 62 mm.
- Measuring table: 80 x 80 x 22 mm.
- Flatness table: $\pm 2 \mu$ m.
- Column: \varnothing 25 mm.
- Base: 150 x 89 x 37 mm.
- Anti drop facility.
- Own product.



Measuring table

Grooved measuring table made of alumina ceramics as applied to measuring stand 334.690, with the typical advantages of ceramics: high degree of hardness and wear resistance.

- Flatness: $\pm 2 \mu$ m.
- Dimensions: 80 x 80 x 22 mm.
- Bottom-side: 3 tapped holes M6.

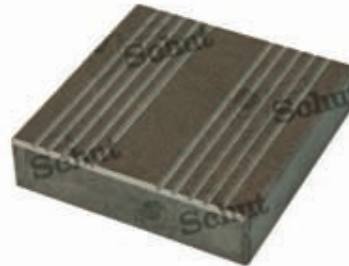

Item No.	Description	Price HRK
334.690	Precision stand	

Item No.	Description	Price HRK
841.078	Measuring table	

Measuring stands

- Clamping shaft: $\varnothing 8$ mm.
- Total height: 310 mm.
- Max. measuring height: 180 mm.
- Hard-chrome plated and ground column: $\varnothing 35$ mm.
- 857.126 and 857.128 with adjustable transverse arm ($\varnothing 22$ mm), length 220 mm.
- Granite measuring table: 260 x 150 x 48 mm (*l x w x h*), measuring face: 200 x 150 mm, flatness according DIN 876/00.

MedioTehna



Item No.	Column	Effective arm length/mm	Price HRK
857.125	plain	104	
857.126	plain	175	
857.127	helical threaded	104	
857.128	helical threaded	175	

Measuring stands

- Clamping shaft: $\varnothing 20$ mm, $\varnothing 25$ mm or $\varnothing 32$ mm.
- Max. measuring height: 290 mm.
- Effective arm length: 167 mm.
- Column: $\varnothing 50$ mm.
- 996.190/315/820 with anti drop facility.
- Granite measuring table: 400 x 400 x 70 mm, flatness: $\leq 5 \mu\text{m}$.
- DIN 876/0.
- Measuring table delivered with a manufacturer measuring report.
- Own product.

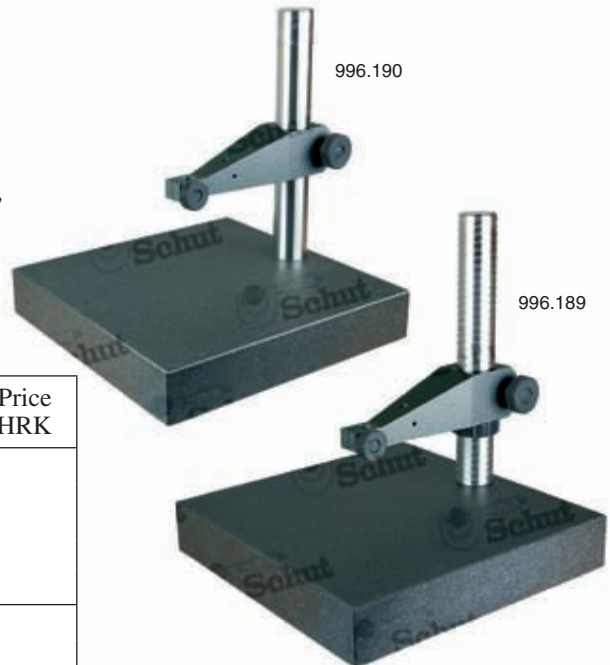

Item No.	Column	Clamping shaft/mm	Price HRK
996.190	plain	$\varnothing 20$	
996.189	helical threaded	$\varnothing 20$	
996.820	plain	$\varnothing 25$	
996.821	helical threaded	$\varnothing 25$	
996.315	plain	$\varnothing 32$	
Option:			
344.470	Reducing bush $\varnothing 20/8$ mm		

Bench center

Cast iron base with the measuring face's accuracy according DIN 876/1. Supplied with two tailstocks, one with a fixed center point and one with an adjustable center point by means of a lever.

- Center height: 100 mm.
- Max. center distance: 450 mm.
- Center points: 60°.
- Stroke moveable center point: 8 mm.
- Delivery incl. measuring stand 857.141 (column $\varnothing 22 \times 230$ mm, clamping shaft 8H7, with fine adjustment), excl. dial indicator or measuring probe.
- Dimensions measuring face: 700 x 180 mm (incl. face for stand).
- Total height: 320 mm. (Height without stand: 200 mm.)
- Width T-slot: 12H7.
- Weight: 35 kg.

- Larger models with granite base are available on request.

Item No.	Type	Price HRK
857.131	RP 100-450	

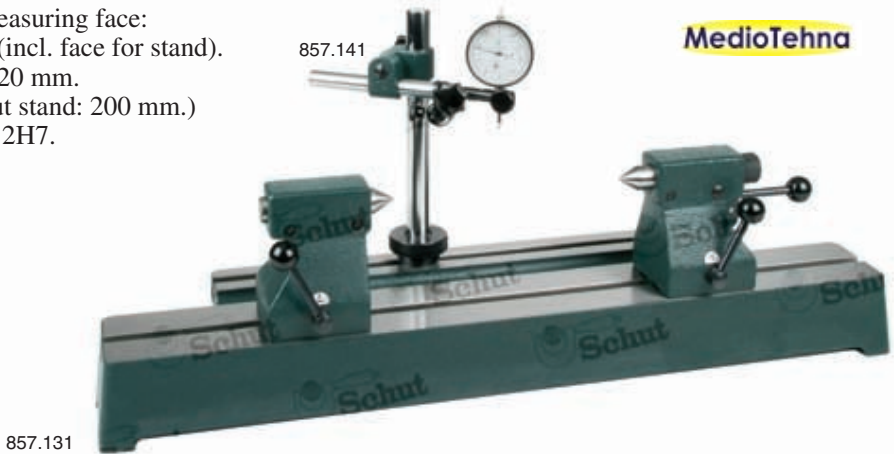

Item No.	Description	Price HRK
857.179	Pair of center points with tungsten carbide point 60°	
857.178	Pair of center points with bore	
857.175	Pair of prism inserts	
857.136	Pair of V-blocks	
857.137	Pair of roller blocks	
857.176	Stop	
857.177	Dial indicator holder	
857.141	Extra measuring stand	

Center points ($\varnothing 22$ mm)

- With tungsten carbide point 60°, or with bore according DIN 332-A 1.6 x 3.8.



Prism inserts 90°

- Capacity: $\varnothing 8$ -45 mm.
- Center height at $\varnothing 10$ mm: 130 mm.



V-blocks 90° and roller blocks

- Capacity V-blocks: $\varnothing 8$ -50 mm.
- Capacity roller blocks: $\varnothing 2$ -60 mm.
- Center height at $\varnothing 10$ mm: 100 mm.
- Stop (857.176): $\varnothing 8$ mm.
- Dial indicator holder (857.177): shaft 8H7.

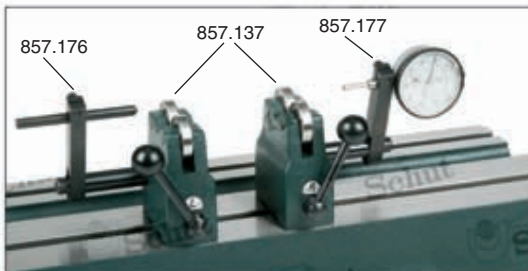

Bench centers

Cast iron base with the measuring face's accuracy according DIN 876/1. Supplied with two tailstocks, one with a fixed center point and one with an adjustable center point by means of a lever.

- Center height: 50 mm (without V-shaped supports) or 75 mm (P models; with V-shaped supports on the tailstocks).
- Max. center distance: 200 or 350 mm.
- Center points: 60°.
- Capacity V-shaped supports: ϕ 5 - 20 mm.
- Stroke moveable center point: 8 mm.
- Delivery incl. measuring stand 857.140 (column ϕ 16 x 220 mm, clamping shaft 8H7, with fine adjustment), excl. dial indicator or measuring probe.
- Dimensions measuring face: 350 x 110 or 500 x 110 mm (including face for measuring stand).
- Total height (incl. measuring stand): 260 mm.
- Width T-slot: 10H7.
- Vertical models are also available.

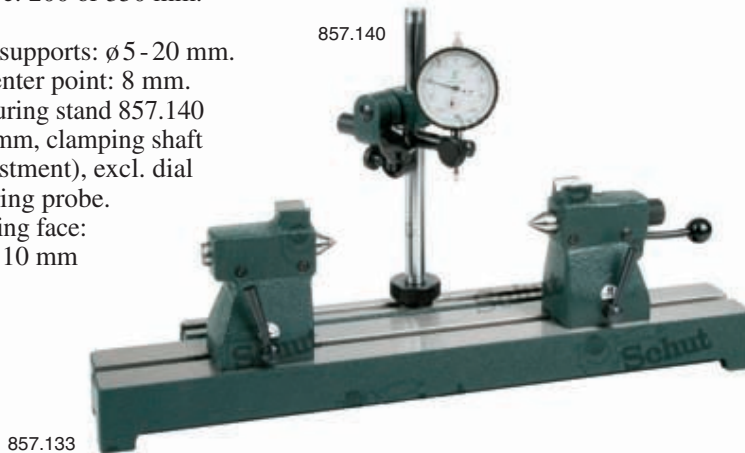

Item No.	Type	Center height mm	Max. center distance/mm	Measuring face/mm	Weight kg	Price HRK
857.132	RP 50-200	50	200	350x110	8	
857.133	RP 75-200P	75	200	350x110	9	
857.134	RP 50-350	50	350	500x110	11	
857.135	RP 75-350P	75	350	500x110	12	

Item No.	Description	Price HRK
857.174	Pair of center points with tungsten carbide point 60°	
857.155	Pair of center points with bore	
857.180	Pair of prism inserts	
857.138	Pair of V-blocks	
857.139	Pair of roller blocks	
857.172	Stop	
857.173	Dial indicator holder	
857.140	Extra measuring stand	



857.138

MedioTehna

Center points (ϕ 16 mm)

- With tungsten carbide point 60°, or with bore according DIN 332-A 1.6 x 3.8.



Prism inserts 90°

- Capacity: ϕ 3 - 15 mm.
- Center height at ϕ 10 mm: 70 mm (RP 50) or 95 mm (RP 75).



V-blocks 90° and roller blocks

- Capacity V-blocks: ϕ 5 - 25 mm.
- Capacity roller blocks: ϕ 2 - 40 mm.
- Center height at ϕ 10 mm: 65 mm.
- Stop (857.172): ϕ 8 mm.
- Dial indicator holder (857.173): shaft 8H7.

Bench center

Bench center with rotatable collet chuck. Cast iron base with the measuring face's accuracy according DIN 876/1.

- Center height: 75 mm.
- Measuring range: 0- 100 mm (up to center).
- Capacity: \varnothing 0.5-9.5 mm.
- Concentricity of the tailstock quill: $\pm 5 \mu\text{m}$.
- Delivery incl. measuring stand 857.140 (column \varnothing 16 x 220 mm, clamping shaft 8H7, with fine adjustment), excl. dial indicator or measuring probe and collet chuck.
- Dimensions measuring face: 200 x 110 mm (DIN 876/1) (incl. face for stand).
- Weight: 5.6 kg (857.184).
- Total height (incl. measuring stand): 270 mm.
- Width T-slot: 10H7.
- Concentricity accuracy collet chucks: 0.03 mm.

MedioTehna



857.274

Item No.	Center height/mm	Price HRK
857.184	75	
Option:		
857.182	Separate tailstock	

Collet chucks

Item No.	Clamping range	Price HRK
857.272	0.5-1	
857.273	1 -1.5	
857.274	1.5-2	
857.275	2 -2.5	
857.276	2.5-3	
857.277	3 -3.5	
857.278	3.5-4	
857.279	4 -4.5	
857.280	4.5-5	
857.281	5 -5.5	
857.282	5.5-6	
857.283	6 -6.5	
857.284	6.5-7	
857.285	7 -7.5	
857.286	7.5-8	
857.287	8 -8.5	
857.288	8.5-9	
857.289	9 -9.5	

Bench center

Bench center with rotatable collet chuck.

- Measuring range: 0- 50 mm (up to center).
- Capacity: \varnothing 0.5-7 mm.
- Clamping shaft: 8H7.
- Excl. dial indicator or measuring probe and collet chuck.
- Weight: 1.8 kg.
- Concentricity accuracy collet chucks: 0.03 mm.



857.190

Item No.	Description	Price HRK
857.185	Bench center	

Collet chucks

Item No.	Clamping range	Price HRK
857.188	0.5-1	
857.189	1 -1.5	
857.190	1.5-2	
857.191	2 -2.5	
857.192	2.5-3	
857.193	3 -3.5	
857.194	3.5-4	
857.195	4 -4.5	
857.196	4.5-5	
857.197	5 -5.5	
857.198	5.5-6	
857.199	6 -6.5	
857.200	6.5-7	

Granite surface plates

Black granite surface plates according to DIN 876 specifications. Sizes vary from 250 x 250 mm to 2000 x 1000 mm.

- Delivery with an inspection report.
- Straight beveled edges.
- Cover (synthetic leather) optionally available.
- Surface plate stand optionally available (see “surface plate accessories” elsewhere in this catalog).
- Weight including wooden transport packaging.



131.101 +
131.113 +
131.108 +
402.028



402.252



MedioTehna

131.100 +
402.028



Delivery ex Groningen, Netherlands

Dimensions <i>l x w x h</i> mm	Weight ¹ kg	Accuracy according DIN 876/1		Accuracy according DIN 876/0		Accuracy according DIN 876/00		Cover ²	
		Item No.	Price HRK	Item No.	Price HRK	Item No.	Price HRK	Item No.	Price HRK
250 x 250 x 50	13	402.000		402.020		402.040		402.250	
400 x 250 x 50	20	402.001		402.021		402.041		402.251	
400 x 400 x 70	41	402.002		402.022		402.042		402.252	
630 x 400 x 70	65	402.003		402.023		402.043		402.253	
630 x 630 x 80	108	402.004		402.024		402.044		402.254	
800 x 500 x 100	136	402.005		402.025		402.045		402.255	
900 x 600 x 100	188	402.006		402.026		402.046		402.256	
1000 x 630 x 100	223	402.007		402.027		402.047		402.257	
1000 x 630 x 150	317	402.008		402.028		402.048		402.257	
1000 x 1000 x 100	342	402.009		402.029		402.049		402.258	
1000 x 1000 x 150	504	402.010		402.030		402.050		402.258	
1200 x 800 x 120	394	402.011		402.031		402.051		402.259	
1200 x 800 x 150	467	402.012		402.032		402.052		402.259	
1500 x 1000 x 150	750	402.013		402.033		402.053		402.260	
1500 x 1000 x 200	971	402.014		402.034		402.054		402.260	
2000 x 1000 x 200	1295	402.015		402.035		402.055		402.261	
2000 x 1000 x 250	1600	402.016		402.036		402.056		402.261	

¹Weight including wooden packing.

²Dimensions of the covers are equal to the length and the width of the surface plate, all covers have a depth of 50 mm.

Cast iron surface plates

Extra heavy, cast iron surface plates.

- Three models:
 - milled (smoothened), accuracy according DIN 876/3,
 - hand scraped, accuracy according DIN 876/1,
 - fine scraped, accuracy according DIN 876/0.
- The side faces of all plates are milled and varnished.
- Surface plate stand optionally available (see “surface plate accessories” elsewhere in this catalog).

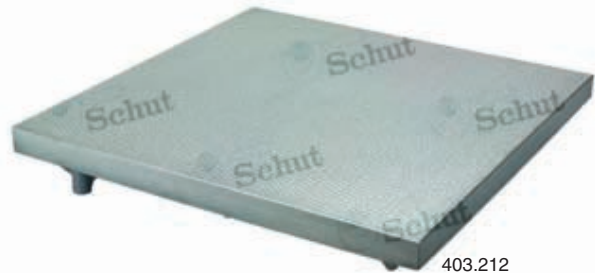

403.212

MedioTehna

Delivery ex Groningen, Netherlands

Dimensions <i>l x w</i> mm	Weight kg (approx.)	Accuracy according DIN 876/3		Accuracy according DIN 876/1		Accuracy according DIN 876/0	
		Item No.	Price HRK	Item No.	Price HRK	Item No.	Price HRK
200 x 200	7	403.236		403.208		403.185	
250 x 250	12	403.237		403.209		403.186	
300 x 300	15	403.238		403.210		403.187	
400 x 250	25	403.239		403.211		403.188	
400 x 400	35	403.240		403.212		403.189	
500 x 500	50	403.241		403.213		403.190	
600 x 400	45	403.242		403.214		403.191	
630 x 630	90	403.243		403.215		403.192	
800 x 500	95	403.249		403.221		403.193	
1000 x 600	140	403.245		403.217		403.194	
1000 x 1000	270	403.246		403.218		403.195	
1200 x 800	300	403.250		403.222		403.196	
2000 x 1000	1000	403.248		403.220			

Fine scraped plate (DIN 876/1) with lapp and inspection surface

Cast iron duplex plate with one flat inspection surface and one squared lapp surface, both finely scraped according to DIN 876/1. With the optional wooden box the surface plate can be used on both sides, because the top and bottom side of the case can be separated.

- Flatness: 14 μm .
- Dimensions *l x w x h*:
360 x 260 x 65 mm.
- Weight: approx. 24 kg.

Item No.	Description	Price HRK
403.150	Duplex plate	
403.151	Wooden case (double sided use)	



Surface plate supports

- For use with large granite or cast iron surface plates with a minimum size of 1000 x 630 mm.
- Support adjustable in height, with adjusting bolt and lock nut.
- For granite and cast iron surface plates it is advisable to use 5 surface plate supports, 3 for the Bessel points and 2 for tilt protection or a set of 5 supports, consisting of 3 surface plate supports and 2 sleeping points.

- Delivery incl. adjusting bolt and lock nut, excl. required supporting cup.

MedioTehna

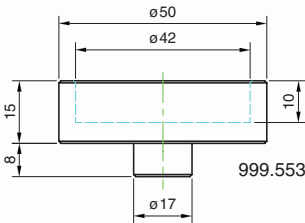

Delivery ex Groningen, Netherlands

403.298 + 999.553 (5 pieces) + 997.343

Item No.	Description	Height/mm		Price HRK
		min. ¹	max. ¹	
403.253	Surface plate support	550	580	
403.254	Surface plate support	650	680	
403.298 ²	Set of 5 supports	550	580	
403.299 ²	Set of 5 supports	650	680	
999.553 ³	Supporting cup (per piece)			
997.343 ⁴	Support set			

¹ Height without supporting cup and supporting set (incl. adjusting bolt and lock nut).

² Set consists of 3 supports and 2 tilt protectors.

³ Required for granite and cast iron surface plates.

⁴ Required for granite surface plates (in combination with supporting cups).



Support with supporting cup and supporting set.



Sleeping point with supporting cup and supporting set.

Support set for surface plates

Support set for placing a small surface plate on a working table.

- Set consists of support based on 3 Bessel points and two tilt protectors.

- Stainless steel construction.
- Diameter: 40 mm.

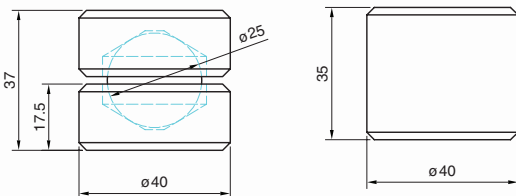

Item No.	Description	Price HRK
997.343	Support set	



Surface plate stands

Extremely solid surface plate stands with excellent price-quality ratio. Support of the surface plate is determined on the basis of the bessel points and has an optional slide protection and chest of drawers. Working height depends on the surface plate thickness. The models for surface plates equal to or larger than 1000 x 1000 mm directly bear the load at the bessel points to the floor.

- Delivered incl. support (bessel) and sleeping points.
- Difference min. and max. height incl. surface plate: 25 mm.
- Delivered in color RAL 7035.



131.101 +
131.113 +
131.108 +
402.028

Delivery ex Groningen, Netherlands

MedioTehna



131.100 +
402.028

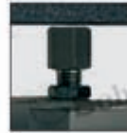

Sleeping point.

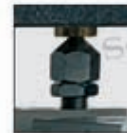

Bessel point.



131.117

Options

Item No.	For granite surface plates dimensions <i>l x w x t</i> /mm	Height incl. surface plate		Price HRK
		min./mm	max./mm	
Surface plate stand (standard model):				
131.100 ¹	630 x 630 x 80	880	905	
131.100 ¹	800 x 500 x 100	900	925	
131.100 ¹	900 x 600 x 100	900	925	
131.100 ¹	1000 x 630 x 100	900	925	
131.100 ¹	1000 x 630 x 150	950	975	
131.104	2000 x 1000 x 200	850	875	
131.104	2000 x 1000 x 250	900	925	
Surface plate stand (prepared for chest of drawers):				
131.101 ¹	630 x 630 x 80	880	905	
131.101 ¹	800 x 500 x 100	900	925	
131.101 ¹	900 x 600 x 100	900	925	
131.101 ¹	1000 x 630 x 100	900	925	
131.101 ¹	1000 x 630 x 150	950	975	
131.102	1000 x 1000 x 100	850	875	
131.102	1000 x 1000 x 150	900	925	
131.102	1200 x 800 x 120	870	895	
131.102	1200 x 800 x 150	900	925	

Item No.	For granite surface plates dimensions <i>l x w x t</i> /mm	Price HRK
131.105	630 x 630 x 80	
131.106	800 x 500 x 100	
131.107	900 x 600 x 100	
131.108	1000 x 630 x 100/150	
131.109	1000 x 1000 x 100/150	
131.110	1200 x 800 x 120/150	
131.111	1500 x 1000 x 150/200	
131.112	2000 x 1000 x 200/250	
Bessel and sleeping points:		
131.115 ^{3,5}	Sleeping point (tilt protection) (height: 30 mm higher than standard)	
131.116 ^{3,4,5}	Bessel point (height: 30 mm higher than standard)	
Surface plate support for extra working height:		
131.117 ⁶	Height: 125 mm higher than standard.	
Chest of drawers:		
131.113 ²	Chest of drawers (RAL 5015), incl. fasteners, 610 x 480 x 470 mm (<i>w x d x h</i>); 3 drawers. Inside dimensions drawers (<i>w x d x h</i>): upper drawer: 515 x 395 x 90 mm, middle drawer: 515 x 395 x 105 mm, lower drawer: 515 x 395 x 135 mm.	

¹ Does not directly bear the load to the floor at the bessel points.

² Incl. fasteners.

³ Sleeping 2 and bessel points 3 needed.

⁴ Excl. brass supporting cup.

⁵ Excl. lock nut.

⁶ For 131.100, 131.101, 131.102: 4 needed.

For 131.103, 131.104: 5 needed.

Granite plate cleaner

Special granite plate cleaner to keep the surface of your granite surface plate clean and useable for a long period. Dust, dirt, grease stains, finger and hand prints can easily be removed. A clean and smooth surface provides low friction, less wear and the most accurate measurements. The non-corrosive property of the cleaner prevents corrosion damage to metal products.



MedioTehna

Item No.	Description	Price HRK
407.304	Cleaner, 500 ml	

Surface plate stands

Extremely solid surface plate stand. Construction is determined on the basis of the Bessel points and has a slide protection. Working height is standard 900 mm.



Delivery ex Groningen,
Netherlands

Item No.	For granite surface plates dimensions l x w x t/mm	Price HRK
131.020	630 x 630 x 80	

Item No.	For cast iron surface plates dimensions l x w/mm	Price HRK
131.030	1000 x 600	
131.029	1000 x 1000	
131.041	1200 x 800	
131.022	1500 x 1000	
131.031	2000 x 1000	

V-blocks / Vises / Angle plates / Cylindrical squares Squares / Parallels / Straight edges

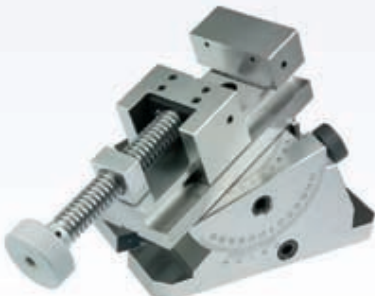

Flatness tolerances according DIN 874	
Class	Flatness t_1 (μm)
00	$1+L/150$
0	$2+L/100$
1	$4+L/60$
2	$8+L/40$

Squareness tolerances according DIN 875	
Class	Squareness (μm)
00	$2+L/100$
0	$5+L/50$
1	$10+L/20$
2	$20+L/10$

Flatness tolerances according DIN 876	
Class	Flatness t_1 (μm)
00	$2+L/500$
0	$4+L/250$
1	$10+L/100$
2	$20+L/50$
3	$40+L/25$

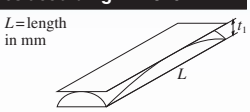

V-blocks in pairs

V-blocks for clamping, processing, aligning and inspecting cylindrical objects, available in three classes.

- **Class 3:** Parallelism: 60 µm.
Base and prism face smooth planed, short and long side processed.
- **Class 1:** Parallelism: 16 µm.
Base and prism face hand scraped, short and long side processed.
- **Class 0:** Parallelism: 8 µm.
Base and prism face and short side fine scraped, long side processed.
- Ground in matched pairs.
- V-groove: 90°.



Dimensions $l \times w \times h$ mm	Capa- city ϕ /mm	Weight p. pair kg	Class 3		Class 1		Class 0	
			Item No.	Price HRK p. pair	Item No.	Price HRK p. pair	Item No.	Price HRK p. pair
Steel:								
100 x 40 x 30	6- 50	1.4	403.396		403.390		403.380	
150 x 50 x 40	8- 60	3.6	403.397		403.391		403.381	
High-quality gray cast iron:								
200 x 70 x 50	8- 75	6.1	403.398		403.392		403.382	
250 x 85 x 60	10-100	10	403.399		403.395		403.383	
300 x 100 x 70	15-120	15	403.400		403.393		403.384	

X-blocks in pairs

The X-blocks have four V-grooves of 90°, all varying in size.

- **Class 1:** Parallelism: 16 µm.
Flatness of the measuring faces according to DIN 876/1.
All surfaces hand scraped.
- **Class 0:** Parallelism: 8 µm.
Flatness of the measuring faces according to DIN 876/0.
All surfaces fine scraped.
- All four V-grooves are ground in matched pairs.
- Material: high-quality gray cast iron.
- V-groove: 90°.
- Holds workpieces on all faces.



Dimensions $l \times w \times h$ mm	Capa- city ϕ /mm	Weight p. pair kg	Class 1		Class 0	
			Item No.	Price HRK p. pair	Item No.	Price HRK p. pair
120 x 100 x 60	8- 90	6	403.370		403.360	
150 x 130 x 75	8-110	10.4	403.371		403.361	
200 x 170 x 90	8-150	25	403.372		403.362	

MedioTehna

Magnetic V-blocks

- Accuracy: ± 0.02 mm / 100 mm.
- On/off switch.
- V-groove: 90° .

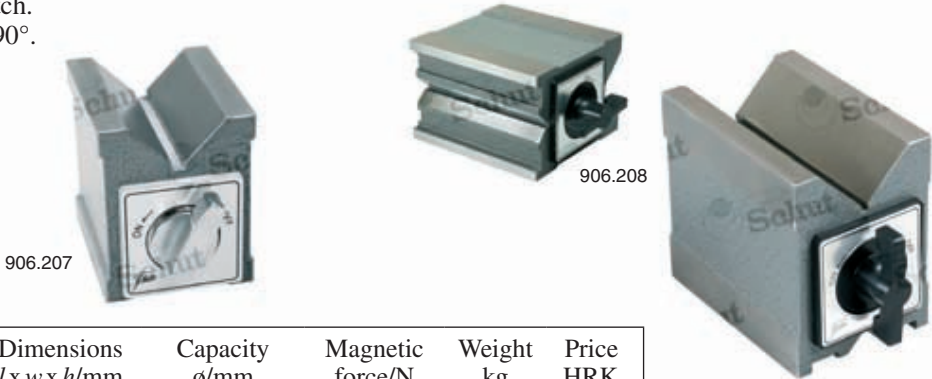

Item No.	Dimensions <i>l x w x h</i> /mm	Capacity ϕ /mm	Magnetic force/N	Weight kg	Price HRK
906.207	70 x 60 x 72	8 - 50	686	1.8	
906.208	100 x 70 x 95	6 - 55	1178	3.7	



Magnetic V-blocks

- Magnetic force: 200 N.
- Ground in matched pairs.
- V-groove: 90° .
- Weight: 2.2 kg (per piece).



Item No.	Dimensions <i>l x w x h</i> /mm	Capacity ϕ /mm	Price HRK
906.210	100 x 50 x 80	6 - 70	

Magnetic V-block

- V-groove: 90° .
- Magnetic force of round spindle axis in V-groove: 450 N, magnetic force of base plate: 450 N.

MedioTehna



Item No.	Dimensions <i>l x w x h</i> /mm	Capacity ϕ /mm	Price HRK
855.200	125 x 60 x 73	6 - 50	

Adjustable V-blocks

V-blocks adjustable from 0 to +60 degrees and 0 to -15 degrees. Suitable for metal cutting machines and for various measuring purposes.

- Vernier: 10'.
- Accuracy: 15'.
- Capacity: \varnothing 6-28 mm (906.600),
 \varnothing 6-40 mm (906.601/602).
- Dial: 0 to +60°/0 to -15°.
- Flatness measuring faces: 0.01 mm.
- Hardness: 50-55 HRC (base),
58-62 HRC (V-block).
- V-groove: 90°.
- Adjustable angle by locking Allen.
- Delivery in a plastic case or a wooden case incl. Allen key.



Item No.	Dimensions l x w x h/mm	Price HRK
906.600	75 x 25 x 32.5	
906.601	102 x 30 x 48	
906.602	102 x 46 x 48	

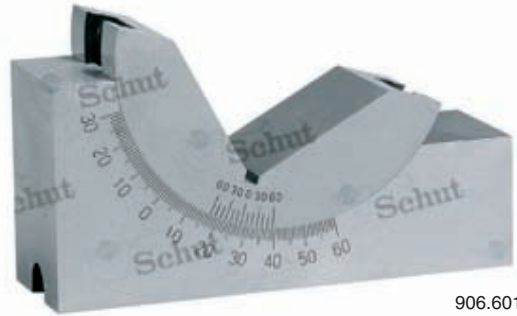

906.601

V-blocks in pairs

- Parallelism measuring faces: $\pm 4 \mu\text{m}$.
- Squareness of front face with bottom face according DIN 2274.
- Hardened ($650 \pm 100 \text{ HV5}$).
- Ground in matched pairs.
- V-groove: 90°.
- Delivery incl. clamp.



666.550

Item No.	Dimensions l x w x h/mm	Capacity \varnothing /mm	Price HRK
666.550	50 x 40 x 40	5-30	
666.551	75 x 55 x 55	5-50	
666.552	100 x 75 x 75	7-70	

V-blocks in pairs

- Parallelism measuring faces: $\pm 4 \mu\text{m}$.
- Squareness of all side faces with each other according DIN 2274.
- Hardened ($650 \pm 100 \text{ HV5}$).
- Ground in matched pairs.
- V-groove: 90°.
- Delivery incl. clamp.

MedioTehna



666.540

Item No.	Dimensions l x w x h/mm	Capacity \varnothing /mm	Price HRK
666.540	60 x 58 x 40	5-30	
666.541	75 x 70 x 54	5-50	
666.542	100 x 96 x 75	7-70	

Granite V-blocks in pairs

- V-groove: 90°.
- Material: granite.
- Processed in matched pairs.
- Delivery in an aluminum carrying case with a manufacturer measuring report.

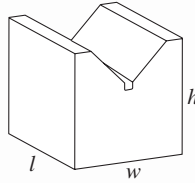

Dimensions <i>l x w x h</i> /mm	Capacity ϕ /mm	Weight kg ¹	Item No.	Accuracy μm^2	Price HRK	Item No.	Accuracy μm^2	Price HRK
			Class 1:			Class 0:		
63 x 63 x 63	10- 50	1.4	402.155	± 6		402.159	± 3	
100 x 100 x 100	15- 75	5.6	402.156	± 8		402.160	± 4	
100 x 160 x 160	25- 125	14.2	402.157	± 8		402.161	± 4	
160 x 250 x 250	60- 200	55.2	402.158	± 10		402.162	± 5	

¹ Weight per pair.

² Parallelism between measuring faces and base.

Magnetic induction blocks in pairs

These magnetic induction blocks are not magnetized themselves. They are placed on a magnetic chuck to induce, to hold objects as for example round bars.

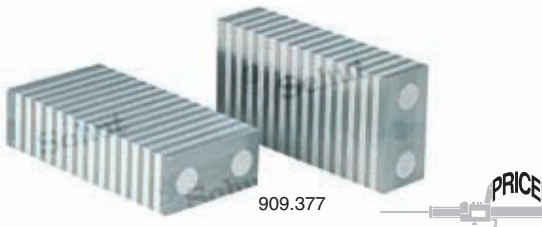

- Material: steel and aluminum alloy.
- Ground in matched pairs.

V-blocks (909.378)

- Capacity: $\phi 7 - 50$ mm.
- V-groove: 90°.

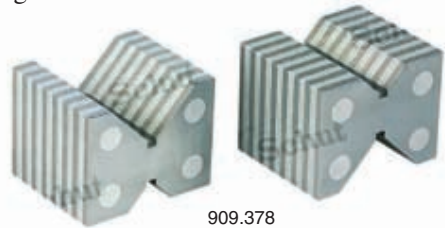

Item No.	Dimensions <i>l x w x h</i> /mm	Weight kg	Price HRK
909.377	100 x 50 x 25	1.18	
909.378	50 x 60 x 48	1.13	

Magnetic holders

- Angles 45°, 90° and 135°.



MedioTehna



909.342

Item No.	Dimensions <i>h x w</i> /mm	Thickness mm	Holding power/kg	Price HRK
909.342	80 x 120	14	2.5	
909.332	100 x 155	17	8	



909.332



Mini precision clamping tools

Miniature clamping tools for clamping of small products. Very well suited for measuring for example with roughness testers, microscopes or measuring machines.

Mini precision vises

- Accuracy (parallelism, flatness and squareness): 0.02 mm.
- 856.081: brass, matt chrome-plated; 856.082 and 856.083: aluminum, matt anodized.
- Standard supplied with 2 pairs of jaws (hardened stainless steel and plastic): 1 side with a ground horizontal and vertical prism and 1 flat side.
- 856.081 and 856.082: on the bottom-side provided with 2 x M4 threaded bores with center distances 42 and 62.5 mm; 856.083: on the bottom-side provided with 2 x M6 threaded bores with center distance approx. 83 mm.

Clamp jaw sets

Sets consisting of 1 pair plastic jaws, 1 pair with stepped jaws and 1 jaw with a stopper in the horizontal prism.



856.081

MedioTehna

Item No.	Jaw opening mm	Jaw width mm	Jaw depth mm	Length mm	Weight kg	Price HRK
856.081	14	15	8	50	0.075	
856.082	23	25	15	75	0.16	
856.083	32	35	21	100	0.4	



Options

Item No.	Description	Price HRK
Clamp jaw sets:		
856.084	For 856.081	
856.085	For 856.082	
856.086	For 856.083	

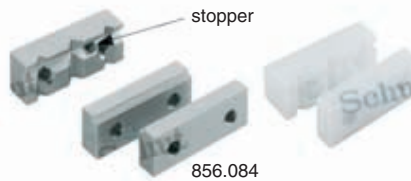

856.084



Mini precision vises in a set

Mini precision vises in a set, consists of 856.081, 856.082 and 856.083 with matching clamp jaws.

- Delivery in a plastic carrying case.

NEW

Item No.	Description	Price HRK
856.175	Mini precision vises in a set	



Mini indexable collets

- Clamping range: 0.4 - 6 mm.
- Per approx. 45 degrees indexable.
- Aluminum, blasted.

MedioTehna



- Mounting by means of two M6 threaded bores on the bottom-side.

Item No.	Clamping range mm	Dimensions l x w x h/mm	Price HRK
856.090	0.4-3.5	26 x 21 x 34	
856.091	1.2-6	26 x 26 x 39	

Stand for mini precision vices

Stand for use with mini precision vices in combination with base plates. The base plates can also be used with other stands. For these stands see dial indicator stands elsewhere in the catalog.

Item No.	Description	Price HRK
670.057	Stand for 856.081 and 856.082	
Base plates:		
856.087	For 856.081	
856.088	For 856.082	
856.089	For 856.083	



XY table for mini precision vices

XY table for accurate positioning underneath a microscope, for example.

- Dimensions: 50 x 50 x 27 mm.
- Range: 10 x 10 mm.
- Graduation micrometers: 0.01 mm.

Item No.	Description	Price HRK
856.176	XY table	
856.177	Adapter for mini precision vise 856.081	
856.178	Adapter for mini precision vise 856.082	

NEW

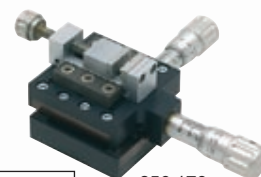
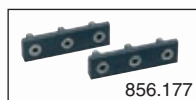

856.176 +
856.177 +
856.081

Mini V-block

- Dimensions: 25 x 20 x 20 mm.
- Hardened stainless steel construction.
- Delivery incl. aluminum clamp.

NEW



Item No.	Description	Price HRK
856.179	Mini V-block for shafts \varnothing 2.5 - 18 mm	

Mini magnetic V-blocks

- V-groove: 120°.
- Hardened and ground steel.



NEW

Item No.	Description	Price HRK
856.173	Mini V-block 20 x 20 x 17.5 mm for shafts \varnothing 2.0 - 25 mm	
856.174	Mini V-block 30 x 30 x 25 mm for shafts \varnothing 4.0 - 35 mm	

Precision vises

Hardened precision vises for accurate measurements and machine operations.

- Accuracy (parallelism, flatness and squareness):
 ≤100 mm jaw opening = 0.005 mm,
 >100 mm jaw opening = 0.005 mm per 100 mm.
- With horizontally and vertically ground prism in the moveable jaw.



Precision and universal sine vises

- Stable and accurate to fix in each angle position (0 to 45°).

Universal precision vise

- With 360° rotatable base.
- Accurate degree scale.
- Stable and accurate to fix in each angle position (0 to 45°).



Item No.	Jaw opening mm	Jaw width mm	Jaw depth mm	Length mm	Price HRK
Precision vises:					
909.733	60	50	25	150	
909.734	80	75	35	200	
909.735	120	100	45	250	
909.736	155	125	50	300	
Precision sine vises with swivelling front axis:					
909.737	25	25	10	65	
909.738	65	50	25	140	
909.739	100	75	35	190	
909.740	120	100	45	240	
909.741	155	125	50	280	
Precision sine vises with swivelling rear axis:					
909.742	60	50	25	140	
909.743	100	75	35	190	
909.744	120	100	45	250	
Universal sine vises:					
909.748	60	50	25	140	
909.749	90	75	35	200	
909.750	120	100	45	250	
909.751	155	125	50	300	
Universal precision vise:					
909.752	80	70	30	-	



MedioTehna

Modular precision vises

Hardened precision vises for fixation for various machine operations.

- With or without 90° rotatable base.
- Accuracy (parallelism, flatness and squareness):
 - ≤ 100 mm jaw opening = 0.005 mm,
 - > 100 mm jaw opening = 0.005 mm per 100 mm.
- Also available:
 - intermediate sizes with other jaw depths and jaw openings,
 - larger models with jaw width 200 or 300 mm and jaw opening up to 600 mm.

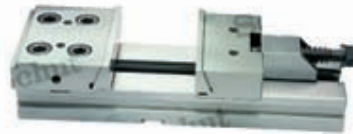

909.702



909.706

MedioTehna

Jaw opening mm	Jaw width mm	Jaw depth mm	Length mm	Without rotatable base		With rotatable base	
				Item No.	Price HRK	Item No.	Price HRK
100	100	30	270	909.702		909.706	
150	125	40	345	909.703		909.707	
200	150	50	420	909.704		909.708	
400	175	60	655	909.705		909.709	



Long modular vises

Long hardened vises for fixation for various machine operations.

- Single or two-sided model.
- Also available:
 - intermediate sizes with other jaw depths and jaw openings,
 - larger models with jaw width 200 mm and jaw opening up to 700 mm (single) or 250 mm (two-sided).



909.710



909.714



Jaw width mm	Jaw depth mm	Length mm	Single			Two-sided		
			Item No.	Jaw opening/mm	Price HRK	Item No.	Jaw opening/mm	Price HRK
100	30	460	909.710	290		909.714	90	
125	40	520	909.711	320		909.715	100	
150	50	580	909.712	360		–	–	
150	50	680	–	–		909.716	160	
175	60	866	909.713	600		909.717	220	

Short modular vises

Short hardened vises for fixation for various machine operations.

- With fixed jaw, fixed double jaw or moveable jaw.



909.723



909.728



909.718



Jaw width mm	Jaw depth mm	Length mm	Height mm	Fixed jaw		Fixed double jaw		Moveable jaw	
				Item No.	Price HRK	Item No.	Price HRK	Item No.	Price HRK
100	30	140	65	909.723		909.728		909.718	
125	40	160	80	909.724		909.729		909.719	
150	50	230	100	909.725		909.730		909.720	
175	60	240	118	909.726		909.731		909.721	
200	65	300	135	909.727		909.732		909.722	

Precision sine plates

- Stable and accurate to fix in each angle position (0 to 45°).

Precision sine plates

- Accuracy (parallelism and squareness):
 ≤ 100 mm dimension l or $w = 0.005$ mm,
 > 100 mm dimension l or $w = 0.005$ mm per 100 mm.
- Mounting hole pattern 909.690: 13x 1/4 inch,
 909.691: 23x 1/4 inch.

MedioTehna

Magnetic precision sine plates

Permanently magnetic sine plates for positioning and holding small or odd-shaped workpieces.

- Center distance of the support cylinders:
 909.690/692: 76 mm,
 909.691/693: 125 mm.



909.690



909.692



Item No.	Dimensions/mm	Price HRK
Precision sine plates:		
909.690	100 x 100 x 50	
909.691	152 x 152 x 57	
Magnetic precision sine plates:		
909.692	100 x 100 x 117	
909.693	152 x 152 x 117	

Granite square blocks with V-nut and tapped holes

Multifunctional granite blocks for e.g. flatness and squareness measurements, with V-nut and several tapped holes. Hold workpieces on several faces.

- Accuracy measuring faces:
 - flatness conforms to DIN 876/0,
 - squareness conforms to DIN 875/1.
- Screw thread of tapping holes:
 - 402.170: M6, 402.171/172: M8.
- Equilateral cubic.
- Delivery with a manufacturer's certificate.



402.170

Item No.	Dimensions mm	Flatness µm	Squareness µm	Weight kg	Price HRK
402.170	160 x 160 x 160	4	8	9.6	
402.171	200 x 200 x 200	5	9	17	
402.172 ¹	250 x 250 x 250	5	10	34	

¹ Delivery ex Groningen, Netherlands.

Four-sided cast iron parallel blocks in pairs

Hollow but yet stable cast iron parallel blocks because of the internal bridge construction.

- **Class 3:** Parallelism: 64 µm. Smooth planed.
- **Class 1:** Parallelism: 16 µm. Hand scraped.
- **Class 0:** Parallelism: 8 µm. Fine scraped.
- Flatness conforms to DIN 876.
- Squareness conforms to DIN 875.
- Plan parallel and square matched in pairs.



403.622

Dimensions l x w x h/mm	Weight p. pair/kg	Class 3		Class 1		Class 0	
		Item No.	Price HRK	Item No.	Price HRK	Item No.	Price HRK
150 x 150 x 100	18	403.628		403.624		403.620	
200 x 150 x 100	28	403.629 ¹		403.625 ¹		403.621 ¹	
300 x 225 x 150	60	403.630 ¹		403.626 ¹		403.622 ¹	
400 x 300 x 200	140	403.631 ¹		403.627 ¹		403.623 ¹	

¹ Delivery ex Groningen, Netherlands.

Cast iron angle blocks with several clamping possibilities

Cast iron angle block, with four clamping faces with several slots and taps, for aligning and clamping of tools and products. The four faces are planparallel and square matched.

- Slot width: 18 mm (403.607: 20 mm).

Item No.	Dimensions l x w x h/mm	Parallelism µm	Squareness µm	Weight kg	Price HRK
403.605	250 x 150 x 100	50	35	13	
403.606	300 x 200 x 150	52	40	23	
403.607 ¹	400 x 250 x 200	56	46	55	



403.606

¹ Delivery ex Groningen, Netherlands.

Cast iron clamping tables with several clamping possibilities

These cast iron clamping tables offer many possibilities for aligning and clamping products for mechanical processing. The six faces are parallel and square milled. Four of these faces are equipped with several clamping slots and the top face with T-slots.

- Flatness according DIN 876/3.
- T-slots according DIN 650.



403.613

Delivery ex Groningen, Netherlands

MedioTehna

Item No.	Dimensions <i>l x w x h</i> /mm	Weight kg	Nom. value T-slots/mm	Slot width mm	Price HRK
403.610	250 x 180 x 150	25	14	16	
403.611	300 x 220 x 200	37	14	18	
403.612	350 x 280 x 250	70	22	22	
403.613	400 x 350 x 300	115	22	22	
403.614	500 x 450 x 400	180	22	22	
403.615	800 x 700 x 600	670	28	30	

Cast iron angle plates with several clamping slots

These cast iron angle plates have several clamping slots both in the base and the clamping face, which make them suitable for all kind of fixtures.

- Flatness according DIN 876.
- Squareness according DIN 875.
- Strengthened outsides.
- Slots in base and clamping face.



403.283

Item No.	Dimensions <i>l x w x h</i> /mm	Weight kg	Flatness and square- ness/ μ m	Slot width mm	Price HRK
Class 3, DIN 876/3, DIN 875/2:					
403.292	150 x 75 x 100	4	30	12	
403.293	200 x 100 x 150	8	30	14	
403.294	275 x 150 x 200	20	40	17	
403.295	300 x 150 x 250	24	45	19	
403.296 ¹	400 x 225 x 300	45	50	23	
403.297 ¹	500 x 300 x 400	85	60	23	
Class 1, DIN 876/2, DIN 875/1:					
403.286	150 x 75 x 100	4	15	12	
403.287	200 x 100 x 150	8	15	14	
403.288	275 x 150 x 200	20	20	17	
403.289	300 x 150 x 250	24	22	19	
403.290 ¹	400 x 225 x 300	45	25	23	
403.291 ¹	500 x 300 x 400	85	30	23	
Class 0, DIN 876/1, DIN 875/0:					
403.280	150 x 75 x 100	4	7	12	
403.281	200 x 100 x 150	8	7	14	
403.282	275 x 150 x 200	20	9	17	
403.283	300 x 150 x 250	24	11	19	
403.284 ¹	400 x 225 x 300	45	12	23	
403.285 ¹	500 x 300 x 400	85	15	23	

¹ Delivery ex Groningen, Netherlands.

Cast iron angle plates

- Ground faces.
- With T-slots.
- Accuracy: flatness according DIN 876, squareness according DIN 875.

MedioTehna



Dimensions <i>l x w x h</i> /mm	Weight kg	DIN 876/3 and 875/2 Item No. Price HRK	DIN 876/2 and 875/1 Item No. Price HRK	DIN 876/1 and 875/0 Item No. Price HRK
150 x 75 x 100	6	403.264	403.261	403.267
200 x 100 x 150	11	403.276	403.273	403.270
275 x 150 x 200	24	403.265	403.262	403.268
300 x 150 x 250	33	403.277 ¹	403.274 ¹	403.271 ¹
400 x 225 x 300	54	403.266 ¹	403.263 ¹	403.269 ¹
500 x 300 x 400	105	403.278 ¹	403.275 ¹	403.272 ¹

¹ Delivery ex Groningen, Netherlands.

LMW steel cylindrical squares

Ground and lapped steel cylinder for checking squareness e.g. during the acceptance process of machines and instruments. Out of roundness and straightness: $\leq 1.5 \mu\text{m}$.

Item No.	Dimensions mm	Squareness p-p/ μm	Price HRK
852.190	$\phi 90 \times 200$	2	
852.191	$\phi 90 \times 250$	2.2	
852.192	$\phi 90 \times 300$	2.5	
852.193	$\phi 90 \times 350$	2.8	
852.194	$\phi 90 \times 400$	3	



Steel cylindrical squares

Ground and lapped steel cylinder for checking squareness.

- Out of roundness and straightness: $\leq 5 \mu\text{m}$.
- Delivery in a wooden case with a manufacturer measuring report.

Item No.	Dimensions mm	Squareness p-p/ μm	Price HRK
906.436	$\phi 80 \times 200$	3	
906.437	$\phi 80 \times 315$	4	
906.438	$\phi 100 \times 500$	5	
906.439	$\phi 140 \times 800$	7	



Granite squares

- Triangular model.
- Material: granite.
- Straight beveled edges.
- With weight-saving holes (except 402.120 and 910.437).

- Delivery in an aluminum carrying case (only height ≤ 400 mm) with a declaration of conformity.

MedioTehna



Item No.	Dimensions <i>h x w x t</i> /mm	Squareness ¹ μm	Flatness ² μm	Weight kg	Price HRK
DIN 875/0:					
402.120	100 x 63 x 16	± 4	2	0.3	
402.121	160 x 100 x 20	± 4	2	0.8	
402.124 ³	630 x 400 x 63	± 9	3	25.5	
DIN 875/00:					
910.437	100 x 63 x 16	± 2	1	0.3	
910.438	160 x 100 x 20	± 2	1	0.8	
910.439	250 x 160 x 25	± 2.5	1	2.4	
910.440	400 x 250 x 40	± 3.5	1.2	7.5	
910.441 ³	630 x 400 x 63	± 4.5	1.5	25.5	
910.442 ^{3,4}	1000 x 630 x 80	± 6	2.5	102	

¹ Squareness between measuring face and base.

² Flatness of measuring face and base.

³ Delivery ex Groningen, Netherlands.

⁴ Weight included package.

Granite squares

- Square model.
- Material: granite.
- Straight beveled edges.
- With weight-saving holes.

- Delivery in an aluminum carrying case (only height ≤ 400 mm) with a declaration of conformity.

Item No.	Dimensions <i>h x w x t</i> /mm	Squareness μm ¹	Weight kg	Price HRK
Class 0:				
402.145	200 x 200 x 25	± 4	2.6	
402.146	250 x 250 x 30	± 4.5	4.9	
402.148	400 x 400 x 40	± 6	14.5	
402.149 ²	500 x 500 x 50	± 7	33	
Class 00:				
910.443	200 x 200 x 25	± 2	2.6	
910.444	250 x 250 x 30	± 2.2	4.9	
910.445	315 x 315 x 30	± 2.6	7.7	
910.446	400 x 400 x 40	± 3	14.5	
910.447 ²	500 x 500 x 50	± 3.5	33	

¹ Squareness between adjacent measuring faces.

² Delivery ex Groningen, Netherlands.



402.148

Ceramic squares

- Made of alumina ceramics.
- Delivery in a wooden case.

MedioTehna



908.721



908.745

PRICE

Item No.	Dimensions <i>l x w x t</i> /mm	Flatness long measuring face/mm	Flatness short measuring face/mm	Squareness mm	Price HRK
Triangular, class A:					
908.719	160 x 100 x 20	0.002	0.001	0.004	
908.720	250 x 160 x 25	0.002	0.002	0.005	
908.721	400 x 250 x 40	0.0025	0.002	0.007	
908.722	630 x 400 x 63	0.003	0.0025	0.009	
Triangular, class AAA:					
908.726	250 x 160 x 25	0.0005	0.0005	0.0025	
908.727	400 x 250 x 40	0.0005	0.0005	0.0035	
908.728	630 x 400 x 63	0.0008	0.0005	0.0045	

Item No.	Dimensions <i>l x w x t</i> mm	Flatness measuring faces/mm	Squareness measuring faces/mm	side faces/mm	Parallelism measuring faces/mm	side faces/mm	Price HRK
Rectangular, class A:							
908.742	200 x 200 x 25	0.0018	0.004	0.04	0.004	0.096	
908.745	400 x 400 x 40	0.0026	0.006	0.06	0.006	0.144	
Rectangular, class AAA:							
908.782	300 x 300 x 30	0.0006	0.0013	0.013	0.0013	0.031	

Ceramic parallels in pairs

Parallels to position and layout workpieces in for example clamping jaws for drilling, grinding, milling and measuring.

- Made of alumina ceramics.
- Delivery in a wooden case.



PRICE

Item No.	Dimensions <i>l x w x h</i> /mm	Flatness measuring faces/mm	Parallelism measur- ing faces/mm	Squareness mm	Height difference/mm	Price HRK
Class A:						
908.733	400 x 63 x 40	0.008	0.008	0.030	0.008	

Ceramic straight edge

- Made of alumina ceramics.
- Delivery in a wooden case.



PRICE

Item No.	Dimensions <i>l x w x h</i> /mm	Flatness measuring faces/mm	Parallelism measur- ing faces/mm	Squareness mm	Price HRK
Class AAA:					
908.789	400 x 60 x 25	0.0016	0.0024	0.008	

Flat steel squares

- Lapped measuring faces.
- Accuracy according DIN 875.

MedioTehna



670.003

Item No.	Dimensions mm	Cross- section/mm	Price HRK
Class III:			
670.061	100 x 70	20 x 5	
670.065	300 x 175	35 x 7	
670.067	500 x 250	40 x 8	
DIN 875/2:			
670.041	75 x 50	15 x 5	
670.042	100 x 70	20 x 5	
670.043	150 x 100	25 x 5	
670.044	200 x 130	30 x 6	
670.045	250 x 165	35 x 7	
670.046	300 x 175	35 x 7	
670.047	400 x 200	35 x 7	
670.048	500 x 250	40 x 8	
670.049	600 x 300	40 x 8	
670.051 ¹	1000 x 500	50 x 10	

Item No.	Dimensions mm	Cross- section/mm	Price HRK
DIN 875/1:			
670.022	75 x 50	15 x 5	
670.023	100 x 70	20 x 5	
670.024	150 x 100	25 x 5	
670.025	200 x 130	30 x 6	
670.026	250 x 165	35 x 7	
670.027	300 x 200	40 x 8	
670.028	400 x 265	45 x 10	
670.029	500 x 330	50 x 10	
670.030	600 x 400	50 x 10	
DIN 875/0 (with inspection report):			
670.002	75 x 50	15 x 5	
670.003	100 x 70	20 x 5	
670.004	150 x 100	25 x 5	
670.005	200 x 130	30 x 6	
670.006	250 x 165	35 x 7	
670.007	300 x 200	40 x 8	
670.008	400 x 265	45 x 10	
670.009	500 x 330	50 x 10	

¹ Delivery ex Groningen, Netherlands.

Flat stainless steel squares

Item No.	Dimensions mm	Cross- section/mm	Price HRK
DIN 875/2:			
670.145	200 x 130	30 x 6	
DIN 875/1:			
670.122	75 x 50	15 x 5	
670.123	100 x 70	20 x 5	
670.124	150 x 100	25 x 5	
670.125	200 x 130	30 x 6	
670.126	250 x 165	35 x 7	
670.127	300 x 200	40 x 8	
670.128	400 x 265	45 x 10	
670.129	500 x 330	50 x 10	
670.130	600 x 400	50 x 10	
DIN 875/0, hardened (with inspection report):			
670.751	50 x 40	12 x 5	
670.752	75 x 50	15 x 5	
670.753	100 x 70	20 x 5	
670.754	150 x 100	25 x 5	
670.755	200 x 130	30 x 6	
670.758	250 x 165	35 x 7	
670.759	300 x 200	40 x 8	
670.760	400 x 265	45 x 10	
670.761	500 x 330	50 x 10	

- Stainless steel.
- Lapped measuring faces.
- Accuracy according DIN 875.



All squares can be delivered with an inspection report or a certificate of an acknowledged measuring laboratory.

For the larger squares it is important to realize that external factors affect the stability of squares, which may influence the accuracy unfavourably.

Wooden cases for squares

Wooden cases for flat squares.



MedioTehna

Item No.	Dimensions square/mm	Price HRK
670.465	50 x 40/75 x 50/100 x 70	
670.466	150 x 100	
670.885	150 x 100/200 x 130	
670.467	200 x 130	
670.468	250 x 165/300 x 200	
670.887	250 x 165/300 x 200	
670.470	500 x 330	

Flat stainless steel squares

- Hardened stainless steel.
- Lapped measuring faces.
- Accuracy according DIN 875.

Item No.	Dimensions mm	Cross- section/mm	Price HRK
DIN 875/1:			
907.301	75 x 50	15 x 5	
907.302	100 x 70	20 x 5	
907.303	150 x 100	25 x 5	
907.304	200 x 130	30 x 6	
907.305	250 x 160	35 x 7	
907.306	300 x 200	40 x 8	
DIN 875/0:			
907.282	50 x 40	12 x 3.5	
907.283	75 x 50	15 x 5	
907.284	100 x 70	20 x 5	
907.285	150 x 100	25 x 7	
907.286	200 x 130	30 x 7	



907.284



Flat steel squares



907.362



907.409



Item No.	Dimensions mm	Cross- section/mm	Price HRK
Acute angle squares 45°, DIN 875/2:			
907.359	100 x 70	20 x 5	
907.360	120 x 80	20 x 5	
907.361	150 x 100	20 x 5	
907.362	200 x 130	25 x 5	
Acute angle squares 60°, DIN 875/2:			
907.383	100 x 70	20 x 5	
907.384	120 x 80	20 x 5	
907.385	150 x 100	20 x 5	
907.386	200 x 130	25 x 5	
Hexagon squares 120°, DIN 875/2:			
907.407	50 x 50	15 x 5	
907.408	75 x 75	18 x 5	
907.409	100 x 100	20 x 5	
907.410	150 x 150	25 x 5	
907.411	200 x 200	30 x 6	
Octagon squares 135°, DIN 875/2:			
907.417	50 x 50	15 x 5	
907.418	75 x 75	18 x 5	
907.419	100 x 100	20 x 5	
907.420	150 x 150	25 x 5	
907.421	200 x 200	30 x 6	

Steel squares with base

- Lapped measuring faces.
- Accuracy according DIN 875.

MedioTehna



670.203

Item No.	Dimensions mm	Cross- section/mm	Price HRK
Class III:			
670.265	300 x 175	35 x 7	
DIN 875/2:			
670.241	75 x 50	15 x 5	
670.242	100 x 70	20 x 5	
670.243	150 x 100	25 x 5	
670.244	200 x 130	30 x 6	
670.245	250 x 165	35 x 7	
670.246	300 x 175	35 x 7	
670.247	400 x 200	35 x 7	
670.248	500 x 250	40 x 8	
670.249	600 x 300	40 x 8	
670.250	750 x 375	45 x 10	
670.251 ¹	1000 x 500	50 x 10	

Item No.	Dimensions mm	Cross- section/mm	Price HRK
DIN 875/1:			
670.222	75 x 50	15 x 5	
670.223	100 x 70	20 x 5	
670.224	150 x 100	25 x 5	
670.225	200 x 130	30 x 6	
670.226	250 x 165	35 x 7	
670.227	300 x 200	40 x 8	
670.228	400 x 265	45 x 10	
670.229	500 x 330	50 x 10	
670.230	600 x 400	50 x 10	
DIN 875/0 (with inspection report):			
670.202	75 x 50	15 x 5	
670.203	100 x 70	20 x 5	
670.204	150 x 100	25 x 5	
670.205	200 x 130	30 x 6	
670.206	250 x 165	35 x 7	
670.207	300 x 200	40 x 8	
670.208	400 x 265	45 x 10	
670.209	500 x 330	50 x 10	

¹ Delivery ex Groningen, Netherlands.

Stainless steel squares with base

Item No.	Dimensions mm	Cross-section/mm	Price HRK
DIN 875/2:			
670.347	300 x 200	40 x 8	
DIN 875/1:			
670.322	75 x 50	15 x 5	
670.323	100 x 70	20 x 5	
670.324	150 x 100	25 x 5	
670.325	200 x 130	30 x 6	
670.326	250 x 165	35 x 7	
670.327	300 x 200	40 x 8	
670.328	400 x 265	45 x 10	
670.329	500 x 330	50 x 10	
670.330	600 x 400	50 x 10	
DIN 875/0, hardened (with inspection report):			
670.851	50 x 40	12 x 5	
670.852	75 x 50	15 x 5	
670.853	100 x 70	20 x 5	
670.854	150 x 100	25 x 5	
670.855	200 x 130	30 x 6	
670.762	250 x 165	35 x 7	
670.763	300 x 200	40 x 8	
670.764	400 x 265	45 x 10	
670.765	500 x 330	50 x 10	

- Stainless steel.
- Lapped measuring faces.
- Accuracy according DIN 875.



670.853

All squares can be delivered with an inspection report or a certificate of an acknowledged measuring laboratory.

For the larger squares it is important to realize that external factors affect the stability of squares, which may influence the accuracy unfavourably.

Wooden cases for squares

Wooden cases for squares with base.



670.885

MedioTehna

Item No.	Dimensions square/mm	Price HRK
670.465	50 x 40 / 75 x 50 / 100 x 70	
670.884	150 x 100	
670.885	150 x 100 / 200 x 130	
670.887	250 x 165 / 300 x 200	
670.888	400 x 265	
670.889	500 x 330	

Stainless steel squares with base

- Hardened stainless steel.
- Lapped measuring faces.
- Accuracy according DIN 875.

Item No.	Dimensions mm	Cross-section/mm	Price HRK
DIN 875/1:			
907.287	75 x 50	15 x 5	
907.288	100 x 70	20 x 5	
907.289	150 x 100	25 x 5	
907.290	200 x 130	30 x 6	
907.291	250 x 160	35 x 7	
907.292	300 x 200	40 x 8	
DIN 875/0:			
907.272	50 x 40	12 x 5	
907.273	75 x 50	15 x 5	
907.274	100 x 70	20 x 5	
907.275	150 x 100	25 x 5	
907.276	200 x 130	30 x 6	



907.274



Steel squares with base



907.368



907.429

MedioTehna



Item No.	Dimensions mm	Cross-section/mm	Price HRK
Acute angle squares 45°, DIN 875/2:			
907.365	100 x 70	20 x 5	
907.366	120 x 80	20 x 5	
907.367	150 x 100	20 x 5	
907.368	200 x 130	25 x 5	
Acute angle squares 60°, DIN 875/2:			
907.389	100 x 70	20 x 5	
907.390	120 x 80	20 x 5	
907.391	150 x 100	20 x 5	
907.392	200 x 130	25 x 5	
Mitre squares 135°, DIN 875/2:			
907.427	100 x 70	20 x 5	
907.428	120 x 80	20 x 5	
907.429	150 x 100	20 x 5	
907.430	200 x 130	25 x 5	

Hardened stainless steel squares with heavy beam

- Hardened stainless steel.
- Lapped measuring faces.
- Accuracy according DIN 875/00.

MedioTehna

Item No.	Dimensions mm	Cross- section/mm	Price HRK
With knife-edges (DIN 875/00):			
670.601	50 x 40	14 x 10/16 x 2	
670.602	75 x 50	14 x 10/18 x 2	
670.603	100 x 70	16 x 10/18 x 2	
670.604	150 x 100	20 x 12/22 x 2	
670.605	200 x 130	24 x 14/26 x 3	



Flange squares

Special fitter's square. For instance for accurate alignment of flanges.

- Material: steel, galvanised.
- Cross-section: 30 x 5 mm.

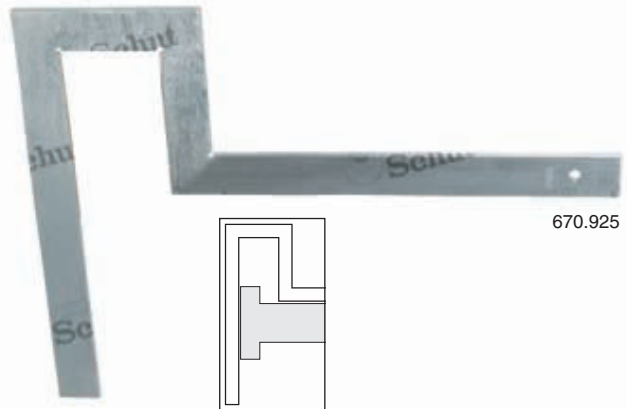
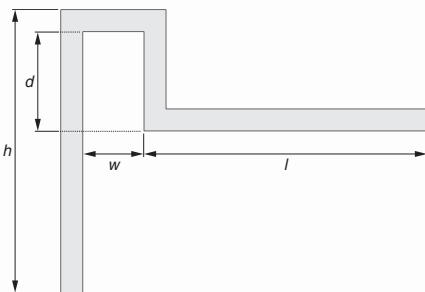

Item No.	Dimensions/mm				Max. deviation from squareness of test surfaces/mm	Max. deviation from flatness of test surfaces/mm	Price HRK
	<i>l</i>	<i>h</i>	<i>w</i>	<i>d</i>			
670.925	300	300	65	105	0.3	0.12	
670.926	400	400	65	115	0.3	0.12	
670.927	500	500	70	125	0.4	0.16	

Adjustable squares

Precise base with sliding straight edge. The straight edge can be moved continuously along the base and can be firmly clamped by the spindle. All measuring faces are ground and the complete square is hardened. The adjustable straight edge enables working with for instance short edges and grooves.



Item No.	Dimensions straight edge/mm	Dimensions base/mm	Price HRK
907.874	60 x 4 x 4	23 x 40 x 10	
909.407	125 x 8 x 8	30 x 75 x 12	



907.874

Squares with heavy beam

- Hardened stainless steel.
- Lapped measuring faces.
- Accuracy according DIN 875/0.



Item No.	Dimensions mm	Cross-section/mm	Price HRK
907.262	50 x 40	14 x 10/16 x 2	
907.263	75 x 50	14 x 10/16 x 2	
907.264	100 x 70	18 x 12/20 x 3	
907.265	150 x 100	24 x 14/25 x 3	
907.266	200 x 130	28 x 16/30 x 4	



907.264

Squares with heavy beam and knife-edges

- Hardened stainless steel.
- Lapped measuring faces.
- Accuracy according DIN 875/00.



Item No.	Dimensions mm	Cross-section/mm	Price HRK
907.245	50 x 40	14 x 10/16 x 2	
907.246	75 x 50	14 x 10/16 x 2	
907.247	100 x 70	18 x 12/20 x 3	
907.248	150 x 100	24 x 14/25 x 3	
907.249	200 x 130	28 x 16/30 x 4	



907.247

Beveled edge squares

- Hardened stainless steel.
- Lapped measuring faces.
- Accuracy according DIN 875/00.



Item No.	Dimensions mm	Cross-section/mm	Price HRK
907.250	50 x 40	12 x 4	
907.251	75 x 50	16 x 4	
907.252	100 x 70	20 x 5	
907.253	150 x 100	25 x 6	
907.254	200 x 130	30 x 7	

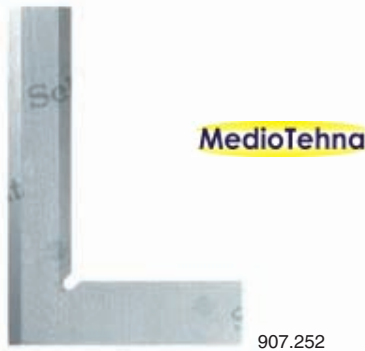

907.252

Beveled edge squares

- Hardened steel.
- Ground and lapped measuring faces.
- Accuracy according DIN 875/00.



670.435

Item No.	Dimensions/mm	Price HRK
Bright steel:		
670.403	50 x 40	
670.404	75 x 50	
670.405	100 x 70	
670.406	150 x 100	
670.407	200 x 130	
Stainless steel:		
670.433	50 x 40	
670.434	75 x 50	
670.435	100 x 70	
670.436	150 x 100	
670.437	200 x 130	

Toolmakers' set

Consisting of:

- 1 beveled straight edge: 100 mm,
- 1 flat beveled edge square: 75 x 50 mm,
- 1 flat beveled edge square: 40 x 28 mm,
- 1 flat beveled edge square: 25 x 20 mm,
- 1 scriber: 8 x 8 x 60 mm.



Item No.	Description	Price HRK
852.201	Toolmakers' set	

Toolmakers' squares

- Hardened stainless steel.
- Lapped measuring faces.
- Accuracy according DIN 875/00.



Item No.	Dimensions mm	Cross-section/mm	Price HRK
907.255	25 x 20	6 x 3.5/5 x 3.5	
907.256	40 x 28	8 x 3.5/5 x 3.5	



Toolmakers' squares

Flat beveled edge squares, with the knife-edge on the inside.

Item No.	Dimensions mm	Angle	Price HRK
852.220	25 x 20	90°	
852.222	40 x 28	90°	
852.223	40 x 28	89°30'	
852.224	40 x 28	90°30'	



Aluminum square with graduation

- Measuring range: 0-300 mm.
- Graduation: 1 mm.
- Anodized aluminum.
- With base for scribing lines in 90° and 45°.
- Cross-section base: 40 x 14 mm, Cross-section ruler: 50 x 5 mm.

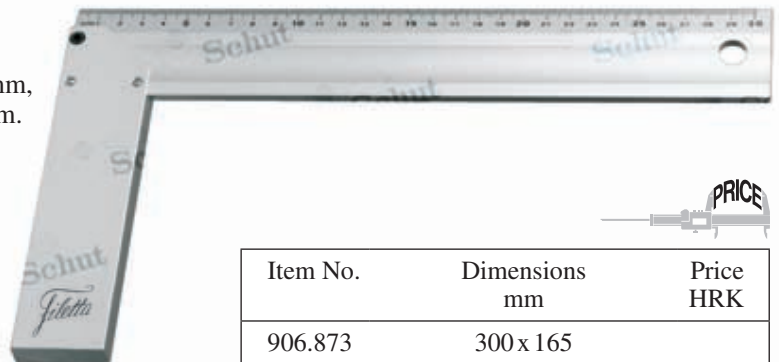

Item No.	Dimensions mm	Price HRK
906.873	300 x 165	

Sine bars

By means of a sine bar and with gauge blocks, a reference plane can be created at an angle of 0° to 60° with respect to the base. The base of the sine bar consists of two rollers with a center to center distance of 100 mm or 200 mm. In order to make a curve the gauge blocks are placed under one of the rollers.

- Straightness and parallelism: 5 µm.
- Surface roughness: Ra0.8 µm.
- Delivery in a plastic case.



NEW

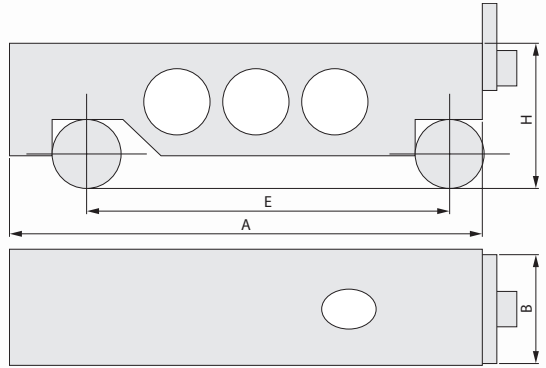

Item No.	A	B	H	E	Price HRK
910.374	130	30	40	100	
910.375	230	30	40	200	

Sine bar

By means of a sine bar and with gauge blocks, a reference plane can be created ($l=150\text{ mm}$, $w=25\text{ mm}$) at an angle of 0° to 60° with respect to the base. The base of the sine bar consists of two rollers with a center to center distance of $127 \pm 0.004\text{ mm}$. In order to make a curve the gauge blocks are placed under one of the rollers.

- Straightness and parallelism: 5 µm.

MedioTehna

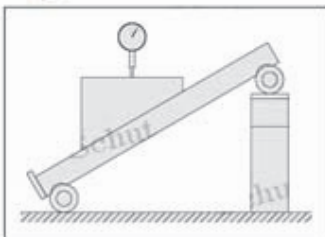

Item No.	Description	Price HRK
909.417	Sine bar	

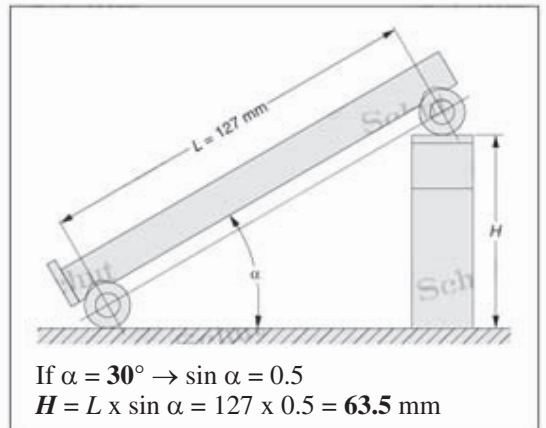

Steel parallel blocks

Parallels to position and layout workpieces in e.g. clamping jaws for drilling, grinding, milling and measuring. The workpieces and assemblies can easily be set up to the desired working height.

- Parallelism of the two measuring faces: ± 0.005 mm.
- Size deviation (height): ± 0.01 mm.
- Hardness: 55 HRC.
- Ground in matched pairs.
- Produced of a high-grade steel alloy.
- Delivery in a wooden case with a declaration of conformity.

MedioTehna



906.996



(Only available in sets.)

Item No.	Length mm	Price HRK	Width mm	Height mm
Set of 12 pairs:				
909.800	100		10	14 - 16 - 18 - 20 - 22 - 24 - 26 - 28 - 30 - 32 - 35 - 40
909.804	125			
906.995	150			
Set of 14 pairs:				
909.802	100		10	14 - 16 - 18 - 20 - 22 - 24 - 26 - 28 - 30 - 32 - 35 - 40 - 45 - 50
909.805	125			
906.996	150			
Set of 24 pairs:				
909.803	100		8	11 - 16 - 21 - 26 - 31 - 36
909.806	125		10	
909.806	125		12	
906.997	150		14	

Adjustable parallel set

Set of 6 adjustable parallels. The parallels consist of 2 precisely ground tapered parts dovetailed together to ensure easy setting. These allow you to quickly clamp a workpiece in the correct position on a workbench, set a measuring instrument or check the internal dimensions of two parallel surfaces.



Parallel	Measuring range/mm	Measuring face length/mm
A	9.5 - 12.7	45
B	12.7 - 17.5	54
C	17.5 - 23.8	69
D	23.8 - 33.3	90
E	33.3 - 44.5	107
F	44.5 - 57.1	117

NEW

Item No.	Size/mm	Price HRK
910.400	9.5 - 57.1 mm	

Granite parallels in pairs

Flatness, parallelism and straightness of measuring surfaces according DIN 874.

- Material: granite.
- Straight beveled edges.
- Delivery in an aluminum case with a declaration of conformity.



Item No.	Flatness/ Parallelism μm^1	Price HRK	Item No.	Flatness/ Parallelism μm^1	Price HRK	Dimensions mm	Weight per pair kg
Class 0, 2-sided:			Class 00, 2-sided:				
402.104	± 3		402.113	± 2		160 x 25 x 16	0.5
402.106	± 8		402.114	± 4		250 x 40 x 25	1.6
			402.115	± 6		400 x 63 x 40	6.5
						630 x 100 x 63	24.7
Class 0, 4-sided:			Class 00, 4-sided:				
402.100	± 3		910.448	± 1.5		160 x 25 x 16	0.5
402.101	± 4		910.449	± 2		250 x 40 x 25	1.6
402.102	± 8		910.450	± 4		400 x 63 x 40	6.5
402.103	± 12		910.451	± 6		630 x 100 x 63	24.7

¹ Flatness and parallelism between opposite surfaces.

Granite straight edges

Flatness, parallelism and straightness of measuring surfaces according DIN 874.

- From length 630 mm with weight-saving holes.
- Material: granite.
- Straight beveled edges.
- Delivery in an aluminum case with a declaration of conformity.



Item No.	Dimensions mm	Weight kg	Straightness/ Flatness/ μm	Parallelism μm	Price HRK
Class 0:					
402.135	400 x 60 x 25	2	± 2.6	± 13	
402.138 ^{1,2}	1600 x 250 x 80	138	± 7.4	± 37	
402.139 ^{1,2}	2000 x 300 x 100	210	± 9	± 45	
Class 00:					
910.452	400 x 60 x 25	2	± 1.6	± 8	
910.453	630 x 100 x 35	6	± 2.1	± 10.5	
910.454 ¹	1000 x 160 x 50	27	± 3	± 15	
910.455 ^{1,2}	1600 x 250 x 80	138	± 4.4	± 22	
910.456 ^{1,2}	2000 x 300 x 100	210	± 5.4	± 27	

MedioTehna

¹ Delivery ex Groningen, Netherlands.

² Weight included package.

Bright steel and stainless steel straight edges DIN 874

High quality wooden cases for straight edges are optionally available. Please see the wooden cases for straight edges section for these wooden cases.

- Length: 500 - 3000 mm.
- Class 0 and 1: rectangular cross-section up to length 1500 mm, from length 2000 mm I-shaped with two grip slots.
Class 2: rectangular cross-section.
- Flatness of the measuring faces according DIN 874.
- Delivery with a manufacturer measuring report (the rectangular version has the manufacturer measuring report engraved on the straight edge).



Class	Dimensions/mm	Weight/kg	Item No.	Price HRK	Item No.	Price HRK
			Bright steel		Stainless steel	
DIN 874/0	500 x 50 x 10	2.0	776.569		776.590	
	750 x 50 x 10	3.0	776.570		776.591	
	1000 x 60 x 12	5.7	776.571		776.592	
	1500 x 70 x 15	12.4	776.572		776.593	
	2000 x 80 x 15	13.0	776.573 ^{1,2}		776.594 ^{1,2}	
	2500 x 100 x 16	22.0	776.574 ^{1,2}		776.595 ^{1,2}	
	3000 x 120 x 18	36.0	776.575 ^{1,2}		776.596 ^{1,2}	
DIN 874/1	500 x 40 x 8	1.3	776.576		776.597	
	750 x 50 x 10	3.0	776.577		776.598	
	1000 x 50 x 10	4.0	776.578		776.599	
	1500 x 60 x 12	8.4	776.579		776.600	
	2000 x 70 x 15	12.0	776.580 ^{1,2}		776.601 ^{1,2}	
	2500 x 80 x 15	17.0	776.581 ^{1,2}		776.602 ^{1,2}	
	3000 x 100 x 16	26.0	776.582 ^{1,2}		776.603 ^{1,2}	
DIN 874/2	500 x 30 x 6	0.7	776.583		776.604	
	750 x 40 x 8	2.0	776.584		776.605	
	1000 x 40 x 8	2.5	776.585		776.606	
	1500 x 50 x 10	5.8	776.586		776.607	
	2000 x 60 x 12	11.2	776.587 ²		776.608 ²	
	2500 x 70 x 15	20.6	776.588 ²		776.609 ²	
	3000 x 80 x 15	28.2	776.589 ²		776.610 ²	

¹ I-shaped with two grip slots.

² Delivery ex Groningen, Netherlands.

Bright steel and stainless steel straight edges DIN 874

High quality wooden cases for straight edges are optionally available. Please see the wooden cases for straight edges section for these wooden cases.

- Length: 500 - 3000 mm.
- Flatness of the measuring faces according DIN 874.
- Straight edges of length 1000 mm and longer are marked on the side face at the Bessel points.

MedioTehna



776.380



776.124*



776.143

Class	Dimensions/mm	Item No.	Price HRK	Item No.	Price HRK
		Bright steel		Stainless steel	
DIN 874/0	1500 x 70 x 15 2500 x 100 x 16 3000 x 120 x 20	776.123 776.125 ^{1,2} 776.126 ^{1,2}		776.223	
DIN 874/1	2500 x 80 x 15			776.235 ^{1,2}	
DIN 874/2	1000 x 40 x 8 2500 x 70 x 15 3000 x 80 x 15	776.143 776.147 ²		776.383 ²	
DIN 874/3	750 x 30 x 6 2000 x 40 x 8 2500 x 40 x 8	776.155 ² 776.156 ²		776.162 776.166 ²	

¹ I-shaped with two grip slots.

² Delivery ex Groningen, Netherlands.

Aluminum straight edges

Light and therefore easy-to-use straight edges. Especially when using longer straight edges this is undoubtedly of great significance. High quality wooden cases for straight edges are optionally available. Please see the wooden cases for straight edges section for these wooden cases.

- Length: 500-3000 mm.
- I-shaped, from length 2000 mm with two grip slots.
- With protective coating, thickness: 50 $\mu\text{m} \pm 5$.
- Surface hardness: 500-550 HV.
- Highly wear resistant.
- Highly corrosion resistant.
- Highly insulating.
- Accuracy according DIN 874.
- Delivery with an inspection report.

MedioTehna



776.618

Item No.	Dimensions mm	Weight kg	Price HRK
DIN 874/0:			
776.611	500 x 60 x 12	0.7	
776.612	1000 x 60 x 12	1.4	
776.613	1500 x 100 x 15	4.3	
776.614 ^{1,2}	2000 x 100 x 15	5.9	
776.615 ^{1,2}	2500 x 100 x 15	7.5	
776.616 ^{1,2}	3000 x 150 x 20	15.9	

Item No.	Dimensions mm	Weight kg	Price HRK
DIN 874/1:			
776.617	500 x 60 x 12	0.7	
776.618	1000 x 60 x 12	1.4	
776.619	1500 x 100 x 15	4.3	
776.620 ^{1,2}	2000 x 100 x 15	5.9	
776.621 ^{1,2}	2500 x 100 x 15	7.5	
776.622 ^{1,2}	3000 x 150 x 20	15.9	
DIN 874/2:			
776.623	500 x 60 x 12	0.7	
776.624	1000 x 60 x 12	1.4	
776.625	1500 x 60 x 12	2.1	
776.626 ^{1,2}	2000 x 60 x 12	2.8	
776.627 ^{1,2}	2500 x 100 x 15	7.5	
776.628 ^{1,2}	3000 x 100 x 15	8.7	

¹ With two grip slots.

² Delivery ex Groningen, Netherlands.

Aluminum straight edges

Light and therefore easy-to-use straight edges. Especially when using longer straight edges this is undoubtedly of great significance. High quality wooden cases for straight edges are optionally available. Please see the wooden cases for straight edges section for these wooden cases.

- Highly wear resistant.
- Highly corrosion resistant.
- Surface hardness: 500-550 HV.
- Highly insulating.
- With protective coating, thickness: 50 µm.
- With grip slots:
class 2: from length 2500 mm,
class 1 and 0: from length 1500 mm.
- Accuracy according DIN 874.



MedioTehna

Item No.	Dimensions mm	Weight kg	Price HRK
DIN 874/2:			
776.194 ^{1,2}	2000 x 60 x 12	2.8	
776.196 ²	3000 x 100 x 16	8.7	

¹ Without grip slots.

² Delivery ex Groningen, Netherlands.

Item No.	Dimensions mm	Weight kg	Price HRK
DIN 874/1:			
776.188 ²	5000 x 150 x 20	26.7	
DIN 874/0:			
776.171 ¹	500 x 60 x 12	0.7	
776.175 ²	2500 x 100 x 16	7.2	

Wooden cases for straight edges

Wooden cases of high quality with foam inlay for straight edges and rulers up to 2 meters.

Item No.	Inside dimensions l x w x h/mm	Price HRK
776.568	525 x 70 x 35	
776.263	765 x 70 x 30	
776.468	1025 x 80 x 35	
776.561 ¹	1525 x 90 x 35	
776.562 ¹	2025 x 95 x 30	

¹ Delivery ex Groningen, Netherlands.



776.568

Steel straight edges for mounting

I-shaped construction with wide and extra wide measuring faces for application of spirit levels.

- Length: 500 - 3000 mm.
- Flatness of the measuring faces according to DIN 874.
- Delivery with an inspection report.

NEW

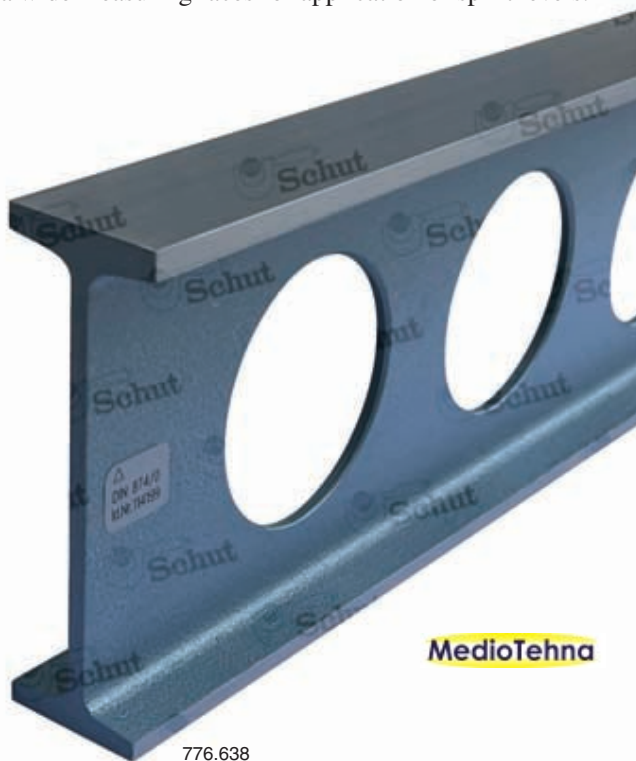

776.638

With wide measuring faces

Dimensions/mm	Weight/kg	Item No.	Price HRK	Item No.	Price HRK
		DIN 874/0		DIN 874/1	
1000 x 100 x 30	5.0	776.631		776.645	
1500 x 100 x 30	7.5	776.632		776.646	
2000 x 120 x 40	15.0	776.633 ¹		776.647 ¹	
2500 x 120 x 40	19.0	776.634 ¹		776.648 ¹	
3000 x 140 x 40	26.0	776.635 ¹		776.649 ¹	

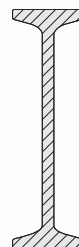

¹ Delivery ex Groningen, Netherlands.

With extra wide measuring faces

Dimensions/mm	Weight/kg	Item No.	Price HRK	Item No.	Price HRK
		DIN 874/0		DIN 874/1	
500 x 80 x 40	2.0	776.636		776.650	
750 x 80 x 40	3.5	776.637		776.651	
1000 x 160 x 50	12.0	776.638		776.652	
1500 x 160 x 50	18.0	776.639		776.653	
2000 x 160 x 50	24.0	776.640 ¹		776.654 ¹	
2500 x 160 x 50	30.0	776.641 ¹		776.655 ¹	
3000 x 180 x 60	45.5	776.642 ¹		776.656 ¹	

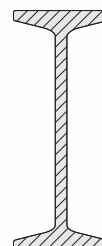

¹ Delivery ex Groningen, Netherlands.

Steel straight edges for mounting

I-shaped construction with wide and extra wide measuring faces for application of spirit levels.

- Length: 500 - 3000 mm.
- Flatness of the measuring faces according DIN 874.



DIN 874/1

Item No.	Dimensions/mm	Price HRK
406.630 ¹	3000 x 140 x 40	
With extra wide measuring faces:		
406.636	500 x 80 x 40	
406.637	750 x 80 x 40	
406.644 ¹	2500 x 160 x 50	
406.631 ¹	3000 x 180 x 60	
Aluminum straight edge		
406.651 ²	1000 x 100 x 40	

DIN 874/0

Item No.	Dimensions/mm	Price HRK
406.613	1000 x 100 x 30	
With extra wide measuring faces:		
406.616	1500 x 160 x 50	

MedioTehna

¹ Delivery ex Groningen, Netherlands.

² Highly corrosion resistant and high insulation.

Cast iron straight edges with handles

Especially suitable for measuring small surfaces.

- Tension free.
- Flatness and parallelism according DIN 876.
- DIN 876/1: hand scraped,
DIN 876/0: fine scraped.
- Both measuring faces are flat and parallel matched in pairs.



Dimensions l x w/mm	Weight approx./kg	DIN 876/1		DIN 876/0	
		Item No.	Price HRK	Item No.	Price HRK
500 x 35	12			403.700	
750 x 50	17	403.706		403.701	
1000 x 56	25	403.707 ¹		403.702 ¹	
1500 x 70	65	403.708 ¹			
2000 x 80	90			403.704 ¹	

¹ Delivery ex Groningen, Netherlands.

Bridge-type straight edges

Made of special close-grained cast iron.

- Tension free.
- Flatness according DIN 876:
class 1: hand scraped,
class 0: fine scraped.



Item No.	l x w mm	Weight kg	Flatness µm	Price HRK
DIN 876/1:				
403.658	500 x 40	6	15	
403.659	750 x 45	9	18	
403.680	1000 x 50	17	20	
403.690 ¹	1500 x 60	45	25	
403.692 ¹	2000 x 70	65	30	
403.698 ¹	3000 x 90	210	40	
DIN 876/0:				
403.657	500 x 40	6	6	
403.660	750 x 45	9	7	
403.679	1000 x 50	17	8	
403.691 ¹	1500 x 60	45	10	
403.696 ¹	2000 x 70	65	12	
403.697 ¹	3000 x 90	210	16	

¹ Delivery ex Groningen, Netherlands.

Triangular straight edges

On two sides scraped, triangular straight edge with screwed-in handles. The edge between the scraped sides (45° or 60°) has been accurately processed. The third side has been ground, and recessed for weight reduction at the larger types (from 500 mm).

- Tension free.
- Flatness of both scraped sides according DIN 876:
class 1: hand scraped,
class 0: fine scraped.



MedioTehna

Item No.	l x w/mm	Weight/kg	Price HRK
Triangular straight edge 45°, DIN 876/1:			
403.525	250 x 50	2	
403.550	500 x 75	7	
403.575	750 x 90	15	
403.600 ¹	1000 x 120	27	
Triangular straight edge 45°, DIN 876/0:			
403.524	250 x 50	2	
403.549	500 x 75	7	
403.574	750 x 90	15	
403.599 ¹	1000 x 120	27	
Triangular straight edge 60°, DIN 876/1:			
403.425	250 x 45	3	
403.450	500 x 60	6	
403.475	750 x 90	16	
403.500 ¹	1000 x 100	28	
Triangular straight edge 60°, DIN 876/0:			
403.424	250 x 45	3	
403.449	500 x 60	6	
403.474	750 x 80	16	
403.499 ¹	1000 x 100	28	

¹ Delivery ex Groningen, Netherlands.

Beveled straight edges

High quality wooden cases for straight edges are optionally available. Please see the wooden cases for straight edges section for these wooden cases.

- Straightness tolerance according DIN 874/00.
- Hardened and ground.
- Lapped measuring faces.
- With insulated grip over the entire length.
- Delivery in a soft case.

MedioTehna



Item No.	Length/mm	Price HRK
Bright steel:		
772.075	75	
772.100	100	
772.125	125	
772.150	150	
772.200	200	
772.300	300	
772.400	400	
772.500	500	

Item No.	Length/mm	Price HRK
Stainless steel:		
772.076	75	
772.101	100	
772.126	125	
772.151	150	
772.201	200	
772.301	300	
772.401	400	
772.501	500	

Beveled straight edges

High quality wooden cases for straight edges are optionally available. Please see the wooden cases for straight edges section for these wooden cases.

- Straightness tolerance according DIN 874/00.
- Hardened and ground.
- Lapped measuring faces.
- With insulated grip over the entire length.
- Delivery in a soft case.



Item No.	Length/mm	Price HRK
Chrome finished steel:		
907.750	75	
907.751	100	
907.752	125	
907.753	150	
907.754	200	
907.755	300	
907.756	400	
907.765	500	
909.237	600	

Item No.	Length/mm	Price HRK
Stainless steel:		
907.757	75	
907.758	100	
907.759	125	
907.760	150	
907.761	200	
907.762	300	
907.763	400	
907.764	500	
909.240	600	

Protractors / Clinometers / Spirit levels



Accuracy of clinometers/spirit levels according DIN 877

Graduation $\mu\text{m}/\text{m}$	"	Flatness (μm) (L =length in mm)
≤ 50	≤ 10	$4 + L/250$
$> 50 - 200$	$> 10 - 40$	$8 + L/125$
> 200	> 40	$16 + L/60$

Universal digital bevel protractor

This digital bevel protractor displays both decimal degrees and degrees-minutes-seconds at the same time.

- Measuring range (switchable): 1x 360°,
2x 180°,
4x 90°.
- Resolution: 0.008° and 30".
- Accuracy: $\pm 0.08^\circ$ or $\pm 5'$.
- On/off switch.
- Reset/preset.
- Reversible measuring direction.
- Fine adjustment.
- Delivery in a wooden case with three blades (150, 200 and 300 mm), a square and an acute angle attachment.
- Power supply: 1 battery type CR2032.



MedioTehna



Single blades

Item No.	Description	Price HRK
907.885	Bevel protractor	
Option:		
495.157	Spare battery type CR2032	

Item No.	Blade length/mm	Price HRK
909.380	150	
909.381	200	
909.382	300	
909.383	500	

Universal digital bevel protractors

Digital bevel protractors made of stainless steel, with blades of 150, 200 or 300 mm. The blades and all the measuring faces are hardened.

- Measuring range (switchable): 1x 360°,
2x 180°,
4x 90°.
- Resolution: 1', or decimal 0.01°.
- Accuracy: $\pm 2'$.
- Clamping spring system for blade.
- Indication switchable from degrees and minutes to decimal degrees.
- Automatic switch-off after 10 minutes of idle time with storage of the displayed measuring value.
- Proximity data output.
- Reset/preset/hold functions.
- Fine adjustment.
- Power supply: 1 battery type CR2032.

MedioTehna



856.688

Complete bevel protractors

Item No.	Blade length/mm	Price HRK
856.688	150	
856.689	200	
856.690	300	

Options:

- 495.157 Spare battery type CR2032
- 856.694 Prism base
- 856.695 Ledge
- 840.666 Proximity USB cable (2 m)

Single blades

Item No.	Blade length/mm	Price HRK
856.685	150	
856.693	200	
856.687	300	



856.694



856.695

Universal digital bevel protractor

This stainless steel, digital bevel protractor is available with blades from 150 to 1000 mm. The blades and all the measuring faces are hardened.

- Measuring range: $\pm 360^\circ$.
- Resolution: 1', or decimal 0.01°.
- Accuracy: $\pm 2'$.
- Repeatability: 1'.
- Indication switchable from degrees and minutes to decimal degrees.
- + and - direction reversible.
- Per 90° adjustable.
- Data output, Mitutoyo Digimatic compatible.
- On/off switch.
- Reset/preset/hold functions.
- Control with 5 keys for several functions.
- Fine adjustment.
- Delivery in a wooden case without blade.
- Power supply: 1 battery type CR2032.



Single blades

Item No.	Description	Price HRK
855.820	Bevel protractor	
Options:		
495.157	Spare battery type CR2032	
905.409	Data cable 2 m	

Item No.	Blade length/mm	Price HRK
909.380	150	
909.381	200	
909.382	300	
909.383	500	
855.827	1000	

Dial bevel protractor

- Measuring range: 4 x 90°.
- Graduation: 5'.
- Fine adjustment.
- Hardened stainless steel construction.
- Delivery in a plastic case with 300 mm blade and an acute angle attachment.

MedioTehna



Item No.	Description	Price HRK
906.504	Bevel protractor	

Single blades

Item No.	Blade length/mm	Price HRK
909.380	150	
909.381	200	
909.382	300	
909.383	500	

Bevel protractor with magnifier

- Measuring range: 4 x 90°.
- Vernier: 5', parallax-free.
- Hardened stainless steel construction.

- Matt chrome-plated scale.
- Delivery in a plastic case with 300 mm blade and an acute angle attachment.



Item No.	Description	Price HRK
906.502	Bevel protractor with magnifier	
Option:		
906.505	Spare magnifier	

Single blades

Item No.	Blade length/mm	Price HRK
909.380	150	
909.381	200	
909.382	300	
909.383	500	

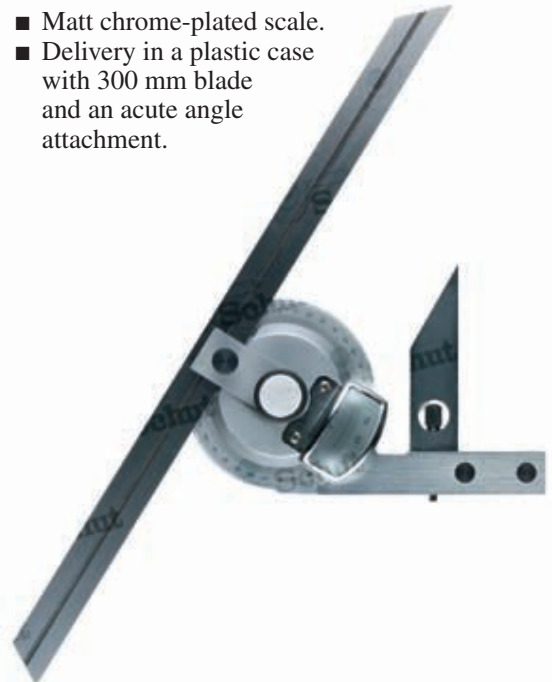

Bevel protractor with magnifier

- Measuring range: $4 \times 90^\circ$.
- Vernier: $5'$, parallax-free.
- Fine adjustment.
- Hardened stainless steel construction.
- Matt chrome-plated scale.

- Delivery in a wooden case with two blades (150 and 300 mm) and an acute angle attachment.

Item No.	Description	Price HRK
855.801	Bevel protractor with magnifier	
Option:		
859.179	Spare magnifier	

Single blades

Item No.	Blade length/mm	Price HRK
909.380	150	
909.381	200	
909.382	300	
909.383	500	



Universal bevel protractor

Universal bevel protractor with micrometer screw adjustment. One rotation of the screw corresponds to an angular change of 1° . Retraction of the micrometer screw enables fast adjustment of the blade and the scale.

- Measuring range: $4 \times 90^\circ$.
- Graduation: $1'$.
- Stainless steel construction, main parts are hardened.
- Delivery in a wooden case with two blades (150 and 300 mm) and a reference square for checking the bevel protractor.



Item No.	Description	Price HRK
855.811	Universal protractor with magnifier	
Option:		
859.019	Spare magnifier	

Single blades

Item No.	Blade length/mm	Price HRK
909.380	150	
909.381	200	
909.382	300	
909.383	500	

Combination bevel protractor

Can be used as bevel protractor, ruler, depth gauge, try square, center square and spirit level.

- Measuring range: 0 - 180° (90 - 0 - 90°).
- Graduation: 1°.
- Double graduation.
- Rotatable.
- Scriber (included in square head).
- Protractor head and square head provided with a spirit level.
- Ruler length: 300 mm.
- Delivery with protractor head, square head, center head, and ruler with mm/mm graduation.



MedioTehna



Item No.	Description	Price HRK
906.503	Combination bevel protractor	

Combination bevel protractor

Stainless steel combination bevel protractor with blade and flat square.

- Measuring range: 0 - 320°.
- Measuring inside and outside angles.
- Accurate adjustment by rack railway.
- Vernier: 2'.
- Delivery in a plastic case.



Item No.	Description	Price HRK
910.215	Combination bevel protractor	

Bevel protractors

Simple and easy to use protractors with a semicircular or rectangular head and swivelling blade.

- Measuring range: 0 - 180°.
- Graduation: 1°.
- Scale diameter: 85 mm.
- Locking screw.
- Blade length: 150 mm.
- Hardened steel, matt chrome-plated.



Item No.	Shape	Price HRK
907.863	semicircular	
909.399	rectangular	



Digital bevel protractors

- Measuring range: 0-180° (with swivelling blade) or 10-170° (with sliding blade).
- Graduation: 0.05°.
- Accuracy: 0.3°.
- On/off switch.
- Reset/hold function.
- Rotatable display value.
- Locking screw.
- Delivery in a plastic case.
- Power supply: 1 battery (CR2032).



Item No.	Scale ø/mm	Blade length/mm	Price HRK
With swivelling blade:			
906.457	120	150	
906.458	150	200	
906.459	200	300	
With sliding blade:			
906.767	100	150	
906.768	150	300	
906.769	200	400	
Option:			
495.157	Spare battery type CR2032		



906.457

MedioTehna



906.767

Bevel protractors

- Measuring range: 0-180° (with swivelling blade) or 10-170° (with sliding blade).
- Graduation: 1°.
- Locking screw.
- Hardened steel, matt chrome-plated.
- Graduation placed by laser.



907.865



907.870

Item No.	Scale ø/mm	Blade length/mm	Price HRK
With swivelling blade:			
907.864	80	120	
907.865	120	150	
907.866	150	200	
907.867	200	300	
907.868	300	500	
With sliding blade:			
907.869	100	150	
907.870	150	300	
907.871	200	400	
907.872	250	500	
907.873	300	600	

Setting bevel

- Special steel.
- Moveable blade locked with a wing nut.



910.088



Item No.	Blade length/mm	Price HRK
910.088	200	
910.089	300	
910.090	500	

Universal digital bevel protractor with spirit level

Digital bevel protractor for measuring both inside and outside angles. The measuring value is displayed upright at any time. Equipped with four holes and a locking knob for measuring a specific angle.

- Measuring range: 360°.
- Resolution: 0.05°.
- Accuracy: ±0.2°.
- ABS/INC switchable.
- With digital-analog display of the measured value.
- Reversal of display value.
- On/off switch.
- Hold function.
- Reversible measuring direction.
- Aluminum casing.
- Rotatable blade of metal.
- Dimensions: 254 x 50 x 36 mm.
- Power supply: 1 battery type CR2032.



MedioTehna



Item No.	Description	Price HRK
909.503	Bevel protractor	
Option:		
495.157	Spare battery type CR2032	

Universal digital bevel protractors

Digital bevel protractors for measuring both inside and outside angles. Equipped with a locking knob for measuring a specific angle.

- Measuring range: $\pm 360^\circ$.
- Resolution: 0.1° .
- Accuracy: $\pm 0.3^\circ$.
- On/off switch.
- Automatic switch-off.
- Zero setting at any position.
- Graduation rulers: 1 mm and 1/32 inch.
- Cross-section rulers: 35 x 2.5 mm.
- With fixing holes.
- Locking screw.
- Power supply: 1 battery type CR2032.



Item No.	Ruler length/mm	Price HRK
909.505	200	
909.506	300	
Option:		
495.157	Spare battery type CR2032	

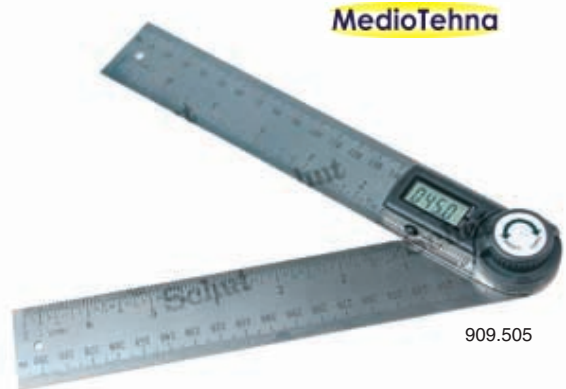

Magnetic clinometer with center point finder

Accurate clinometer with an extremely sensitive, balanced needle. The magnetic base with 90° V-groove is precision milled. The center point finder can be used as a center punch.

Very suitable for angular measurements, surface alignment, and the determination of center points and highest/lowest points of cylindrical and spherical surfaces. Therefore ideal as a universal aid to the installation of larger constructions.

- Measuring range: 360° .
- Graduation: 1° .
- Scale numbering: 0 - 360.
- Aperture V-groove (horizontal): 82 mm (for shafts up to $\varnothing 115$ mm).
- Dimensions $h \times w \times d$: 130 x 130 x 27 mm.

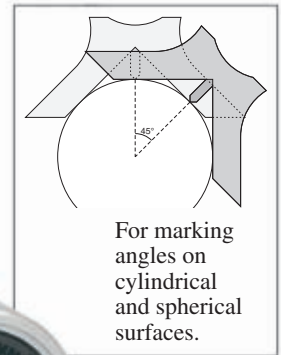

Item No.	Scale numbering	Price HRK
856.702	0 - 360	
Option:		
856.712	Center pin $\varnothing 12 \times 125$ mm	



Digital clinometer

- Measuring range: 0-±180°.
- Resolution: 0.1°.
- Accuracy: ±0.2°.
- Rotatable display.
- Automatic switch-off.
- Hold function.
- Reference measurement function.

- With digital-analog read-out of the vial.
- With magnetic base with V-groove.
- Dimensions: 60 x 56 x 33 mm.
- Power supply: 2 batteries type AAA.

Item No.	Description	Price HRK
906.427	Digital clinometer	
Option:		
497.914	Spare battery type AAA (2 needed)	



Digital clinometers

- Measuring range: ±180° (with external sensor: ±360°).
- Resolution: 0.1°.
- Accuracy 0- 10°: ±0.1°, 10-170°: ±0.2°, 170-180°: ±0.1°.
- Repeatability: 0.1°.

- ABS/INC switchable (except 906.476).
- Automatic switch-off.
- Hold function (only 906.479).
- With magnetic base (906.476/479) or magnetic upper part (909.501/502).
- Dimensions: 51 x 51 x 33 mm (906.476 and 909.501/502).
- Power supply: 1 battery type CR2032.

Models with external sensor

- Accuracy 0- 10°: ±0.1°, 10-350°: ±0.2°, 350-360°: ±0.1°.
- Sensor with mounting holes.
- Cable length: 1 m.
- Max. rotation speed: 600 rpm.



906.476



909.501



909.502

MedioTehna



906.479

Item No.	Description	Price HRK
906.476	Standard model	
906.479	With vial	
909.501	With external sensor	
909.502	With external sensor with axis ø6 mm	
Option:		
495.157	Spare battery type CR2032	

Digital clinometer

Instrument for easy measurement of angles, flatness and squareness. All four sides are measuring faces. The measuring value is displayed upright at any time.

- Measuring range: $4 \times 90^\circ$.
- Resolution: 0.05° .
- Accuracy $0-10^\circ: \pm 0.1^\circ$,
 $10-80^\circ: \pm 0.2^\circ$,
 $80-90^\circ: \pm 0.1^\circ$.
- Repeatability: 0.1° .
- ABS/INC switchable.
- Large, easy-to-read LCD display.
- Automatic switch-off.
- Hold function.
- Blue backlight.
- Sound signal at stable value.
- $^\circ$, mm/m, %, inch/ft conversion.
- Reference plane function.
- Measuring faces bottom- and upper-side with V-groove.
- With magnetic base (2 magnets).
- Protection: IP65.
- Dimensions $l \times w \times h$: 151 x 32 x 60 mm.
- Delivery in a soft case.
- Power supply: 2 batteries type AAA.



MedioTehna



Item No.	Description	Price HRK
909.504	With V-grooves and magnetic base	
Option:		
497.914	Spare battery type AAA (2 needed)	

Digital clinometer

Instrument for easy measurement of inclination. Equipped with a horizontal and vertical vial. The measuring value is displayed upright at any time.

- Measuring range: 4 x 90°.
- Resolution: 0.1°.
- Accuracy 0-10°: ±0.1°,
10-80°: ±0.2°,
80-90°: ±0.1°.
- ° and % conversion.
- Large, easy-to-read LCD display.
- On/off switch.
- Hold function.
- Sound signal at: 0°, 45°, 90°.
- Measuring face on the bottom- and upper-side.
- Length: 600 mm.
- Delivery in a carrying bag.
- Power supply: 2 batteries type AAA.



906.477

MedioTehna

Item No.	Description	Price HRK
906.477	Clinometer	
Option:		
497.914	Spare battery type AAA (2 needed)	

Laser alignment tool

With this alignment tool you can precisely, quickly and easily project vertical, horizontal and crossed laserlines. Within a range of ±4° minor inclination errors are automatically compensated by means of the integrated spirit level, to level the projected horizontal line.

- Range: up to 30 m (dependent on the lighting conditions).
- Self-levelling range: 4°.
- Horizontal and vertical accuracy: ±4.5 mm/15 m.
- Laser: 510-530 nm, class 2 conform to IEC 60825-1/2007.
- Lock function for projecting at an angle and transport protection.
- On/off switch.
- Dimensions: 74 x 64 x 75 mm.
- Weight: 270 g.
- Protection: IP54.
- Intake internal thread on the bottom-side: UNC 1/4"-20, thread depth: 8 mm.
- Delivery in a soft case including a plastic mounting bracket with 2 strong magnets.
- Power supply: 2 batteries type AA.

NEW

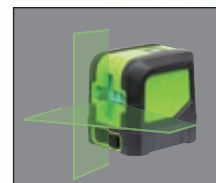
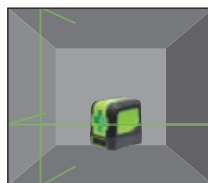

Item No.	Description	Price HRK
910.369	Alignment tool	
Option:		
495.111	Spare battery type AA (2 needed)	

Clinometers

- Measuring range: 4 x 90°.
- Graduation: 1°.
- Dimensions: 100 x 15 x 100 mm.



857.302

Item No.	Description	Price HRK
857.302	Clinometer with removable base 100 mm	
857.303	Clinometer with magnetic base 100 mm	

Vernier clinometers

Clinometers with two ground bases with V-groove, or two flat magnetic bases. Vial holder with vernier and fine adjustment.

- Measuring range: 0 - 90°.
- Vernier: 10'.
- Graduation vial: 0.3 mm/m \cong 1'.
- Dimensions: 150 x 39 x 150 mm.

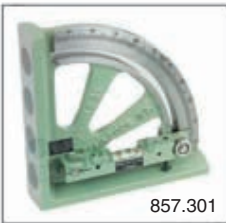

857.301



857.300

Item No.	Description	Price HRK
857.300	Bases with V-groove	
857.301	Flat magnetic bases	

Clinometer

- Measuring range: 4 x 90°.
- Graduation: 1°.
- Graduation vial: 2 - 5 mm/m.
- Flat base: 300 x 25 mm.
- With mounting holes.



Item No.	Description	Price HRK
853.669	Clinometer	

Clinometer

To determine inclinations accurately. Fine-tuning by means of a screw thread spindle, which, to ensure a quick tuning, can be disconnected by pressing the button on the micrometer.

- Measuring range: $\pm 180^\circ$.
- Read-out in degrees and minutes.
- Scale numbering black clockwise, red counterclockwise.
- Graduation vial: 0.3 mm/m \cong 1'.
- Hardened and ground base, with V-groove.
- Base dimensions: 150 x 30 mm.
- Height: 124 mm.



Item No.	Description	Price HRK
857.310	Clinometer	

Digital inspection spirit level and digital frame spirit level

Accurate digital spirit levels in a high grade cast iron housing with fine ground measuring surfaces. The measuring value can be displayed in an App on an Android or Apple phone via Bluetooth.

- Measuring range: $\pm 15^\circ$.
- Graduation: 0.02 mm/m.
- Accuracy according to DIN 2276-2: 0.0015° or $0.04\%H$ (H= Measured value).
- Measuring units: 13; e.g. mm/m, mm/200 or mm/150, inch/ft, $^\circ$, %.
- ABS/INC switchable.
- Hold function.
- Color display with backlight.
- Temperature compensation.
- Semi-automatic calibration.
- Remote display by Bluetooth.
- Measuring surfaces fine ground: inspection spirit level: base with V-groove, frame spirit level: 3 faces with V-groove and 1 flat face.
- Dimensions:
inspection spirit level: 200 x 47 x 42 mm,
frame spirit level: 150 x 150 x 42 mm.
- Weight:
inspection spirit level: 3.4 kg,
frame spirit level: 4.4 kg.
- DIN 877 and DIN 2276-2.
- Delivery in a plastic case with an AC adapter.



853.600



853.651

MedioTehna

Item No.	Description	Price HRK
853.600	Digital inspection spirit level	
853.651	Digital frame spirit level	



Inspection spirit levels

- Graduation main vial: 0.01 - 0.3 mm/m.
- With cross test vial.
- Base with V-groove.
- Base width: 42 mm
(spirit levels with length 500 mm: 44 mm).
- DIN 877.
- Delivery in a plastic case or wooden case.

Item No.	Length mm	Graduation mm/m	Price HRK
853.601	160	0.3	
853.606	160	0.1	
853.611	160	0.04	
853.616	160	0.02	
853.602	200	0.3	
853.607	200	0.1	
853.612	200	0.04	
853.617	200	0.02	
853.621	200	0.01	
853.603	250	0.3	
853.608	250	0.1	
853.613	250	0.04	
853.618	250	0.02	
853.622	250	0.01	
853.604	300	0.3	
853.609	300	0.1	
853.614	300	0.04	
853.619	300	0.02	
853.623	300	0.01	
853.605	500	0.3	
853.610	500	0.1	
853.615	500	0.04	
853.620	500	0.02	
853.624	500	0.01	

Inspection spirit levels

- Graduation main vial: 0.02 - 0.5 mm/m.
- Adjustable main vial.
- With cross test vial.
- Base with V-groove, interrupted at the center over 1/3 of the length.
- Base width: 40 mm.
- DIN 877.
- Delivery in a plastic case or wooden case.



Item No.	Length mm	Graduation mm/m	Price HRK
853.343	150	0.5	
853.341	150	0.1	
853.315	150	0.05	
853.348	150	0.02	
853.345	200	0.5	
853.344	200	0.1	
853.323	200	0.05	
853.322	200	0.02	
853.347	300	0.5	
853.346	300	0.1	
853.324	300	0.05	
853.325	300	0.02	



MedioTehna

Inspection spirit levels

- Graduation main vial: 0.05 or 0.02 mm/m.
- Adjustable main vial.
- With cross test vial.
- Base with V-groove.
- Base width: 46 mm.
- Robust cast iron construction.
- With insulating grip.
- DIN 877.
- Delivery in a wooden case.



908.685

Item No.	Length mm	Graduation mm/m	Price HRK
908.688	150	0.05	
908.684	150	0.02	
908.689	200	0.05	
908.685	200	0.02	
908.690	250	0.05	
908.686	250	0.02	
908.691	300	0.05	
908.687	300	0.02	

MedioTehna

Frame spirit levels

- Graduation main vial: 0.05 or 0.02 mm/m.
- Adjustable main vial.
- With cross test vial.
- Two faces with V-groove, two flat faces.
- Robust cast iron construction.
- With insulating grip.
- DIN 877.
- Delivery in a plastic case or wooden case.



908.693

Item No.	Dimensions mm	Graduation mm/m	Price HRK
908.696	150 x 150 x 40	0.05	
908.692	150 x 150 x 40	0.02	
908.697	200 x 200 x 40	0.05	
908.693	200 x 200 x 40	0.02	
908.698	250 x 250 x 40	0.05	
908.694	250 x 250 x 40	0.02	
908.699	300 x 300 x 40	0.05	
908.695	300 x 300 x 40	0.02	

Frame spirit levels

- Graduation main vial: 0.01 - 0.3 mm/m.
- With cross test vial.
- Three faces with V-groove, one flat face.
- DIN 877.
- Delivery in a plastic case or wooden case.



853.638

Item No.	Dimensions mm	Graduation mm/m	Price HRK
853.625	100 x 100 x 34	0.3	
853.629	100 x 100 x 34	0.1	
853.633	100 x 100 x 34	0.04	
853.626	150 x 150 x 42	0.3	
853.630	150 x 150 x 42	0.1	
853.634	150 x 150 x 42	0.04	
853.637	150 x 150 x 42	0.02	
853.627	200 x 200 x 42	0.3	
853.631	200 x 200 x 42	0.1	
853.635	200 x 200 x 42	0.04	
853.638	200 x 200 x 42	0.02	
853.640	200 x 200 x 42	0.01	
853.628	300 x 300 x 44	0.3	
853.632	300 x 300 x 44	0.1	
853.636	300 x 300 x 44	0.04	
853.639	300 x 300 x 44	0.02	
853.641	300 x 300 x 44	0.01	

Frame spirit levels

- Graduation main vial: 0.02 - 0.5 mm/m.
- Adjustable main vial.
- With cross test vial.
- Three faces with V-groove, interrupted at the center over $\frac{1}{3}$ of the length. One flat face.
- DIN 877.
- Delivery in a plastic case or wooden case.

Item No.	Dimensions mm	Graduation mm/m	Price HRK
853.372	150 x 150 x 40	0.5	
853.371	150 x 150 x 40	0.1	
853.375	150 x 150 x 40	0.05	
853.376	150 x 150 x 40	0.02	
853.374	200 x 200 x 40	0.5	
853.373	200 x 200 x 40	0.1	
853.385	200 x 200 x 40	0.05	
853.382	200 x 200 x 40	0.02	
853.395	250 x 250 x 40	0.05	
853.392	250 x 250 x 40	0.02	



MedioTehna

853.376

Crankshaft spirit levels

- Graduation main vial: 0.04 - 0.6 mm/m.
- With cross test vial.
- Base with a longitudinal and a lateral V-groove.



- Base width: 42 mm.
- DIN 877.

Item No.	Length mm	Graduation mm/m	Price HRK
853.684	60	0.6	
853.687	60	0.2	
853.682	90	0.3	
853.685	90	0.1	
853.688	90	0.04	
853.683	120	0.3	
853.686	120	0.1	
853.689	120	0.04	

Aluminum spirit levels

- Graduation vial: 0.6 mm/m.
- Base with V-groove.
- Base width: 22 mm.
- DIN 877.

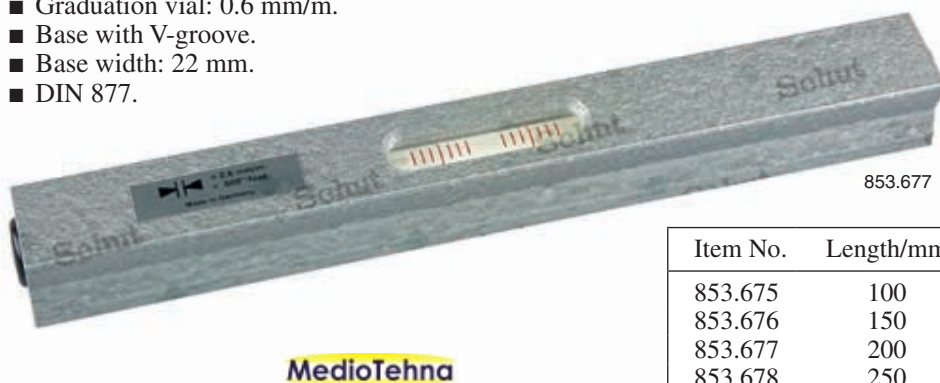

Item No.	Length/mm	Price HRK
853.675	100	
853.676	150	
853.677	200	
853.678	250	
853.679	300	

Small spirit levels

Intended for simple tasks.

- Graduation vial: 0.1 or 0.3 mm/m.
- With longitudinal spirit level.
- Width: 24 mm.

- Equipped with mounting holes $\varnothing 5$ mm.
- Flat base.
- DIN 877.

Item No.	Length mm	Graduation mm/m	Price HRK
853.665	100	0.3	
853.666	100	0.1	
853.667	150	0.3	
853.668	150	0.1	



Cross spirit levels

Cross spirit levels with two vials, in cast iron casing
80 x 80 mm, cross-section 20 x 20 mm, with two
screw holes ϕ 4 mm.

MedioTehna

Item No.	Graduation mm/m	Price HRK
857.338	0.4	
857.339	0.1	
857.340	0.05	



857.338



857.342

Cross spirit levels with two vials, in circular chrome casing
with three screw holes ϕ 4 mm.

Item No.	Graduation mm/m	Dimensions mm	Screw holes ϕ /mm	Price HRK
857.342	0.4	ϕ 80 x 23	4	
857.343	0.1	ϕ 80 x 23	4	

Spirit levels with flat base

Spirit levels with a stainless steel strip base, no
screw mounting, with an adjustable plexiglass vial
mounted onto it, graduation approx. 5 mm/m.

Item No.	Dimensions base <i>l x w x t</i> /mm	Price HRK
857.344	100 x 20 x 5	
857.345	150 x 20 x 5	
857.346	200 x 20 x 5	



857.344

Spirit levels with a stainless steel strip base, no screw
mounting, with two ground contact planes. Mounted
onto this an adjustable spirit level with cast iron housing,
graduation 1 mm/m.

Item No.	Dimensions base <i>l x w x t</i> /mm	Price HRK
857.347	100 x 20 x 5	
857.348	150 x 20 x 5	
857.349	200 x 20 x 5	



857.347

Circular spirit levels

Item No.	Diameter mm	Height mm	Sensitivity* mm/m	Price HRK
Plexiglass model with yellow and green base:				
857.315	12	7	approx. 22	
857.316	15	8	approx. 22	
857.317	18	9	approx. 22	
857.318	30	10	approx. 22	
Black synthetic model with frame and screw holes $\varnothing 2.5$ mm and yellow and green base:				
857.320	26/17	7 +3	approx. 19	
857.321	30/20	7.5+3.5	approx. 19	
Chrome casing and white base:				
857.323	15	10	approx. 8	
857.324	18	10	approx. 8	
Chrome casing with frame and screw holes $\varnothing 2.5$ mm (857.325: $\varnothing 1.5$ mm; 857.330/331: $\varnothing 3.5$ mm) and white base:				
857.325	20/13.5	7 +2	approx. 8	
857.326	25/17	7.5+2.5	approx. 8	
857.327	30/17	6.5+3.5	approx. 8	
857.328	35/20	7.5+3.5	approx. 6	
857.329	40/25	8 +4	approx. 6	
857.330	50/34	9.5+5.5	approx. 3	
857.331	60/39	10 +7	approx. 3	
857.332	25/17	7.5+2.5	approx. 2	
White, synthetic casing with frame and screw holes $\varnothing 3$ mm, additional scale circles and white base:				
857.336	60/45	4+6	Reading $0^{\circ} - 2^{\circ} - 5^{\circ}$	
Black, synthetic casing with frame and screw holes $\varnothing 5$ mm, additional scale circles and white base:				
857.337	100/75	5+10	Reading $0^{\circ} - 3^{\circ} - 6^{\circ}$	

* Sensitivity means: the angle at which the air bubble is moved to the next scale mark or edge of the vial.



Hose water level

- Measuring range: 15 cm.
- Graduation: 1 mm.
- Scale numbering: 0.5 - 15.5 cm.
- Hose length: 20 m (reducible).
- Hose cross-section: 9.5 mm.

Item No.	Description	Price HRK
906.819	Hose water level	



Roughness specimens



Roughness specimens

Series of roughness specimens, type Microsurf, covering the nine most frequently occurring manufacturing operations; per set eight specimens will be delivered. In addition to the roughness value R_a in μm , the roughness value CLA in μin and the N values are specified.



MedioTehna

Item No.	Machining-method	Number of specimens per set	Roughness R_a μm	Roughness CLA μin	Roughness class N	Price HRK
850.315	Surface grinding	8	0.025- 3.2	1- 125	1- 8	
850.316	Cylindr. grinding	8	0.025- 3.2	1- 125	1- 8	
850.319	Face turning	8	0.4 - 50	16-2000	5-12	
850.320	Turning	8	0.4 - 50	16-2000	5-12	
850.321	End milling	8	0.4 - 50	16-2000	5-12	
850.322	Reaming & drilling	8	0.4 - 12.5	16- 500	5-10	
850.323	Horizontal milling	8	0.4 - 50	16-2000	5-12	
850.325	Planing	8	0.8 -100	32-4000	6-13	
850.331	Spark erosion	8	0.4 - 50	16-2000	5-12	

Available with declaration of conformity on request.

Wall chart

Eight Microsurf roughness specimens, mounted on a general reference chart, can be obtained for the following manufacturing operations:

- Surface grinding, cylindrical grinding, face turning, turning, end milling, reaming & drilling, horizontal milling and planing.
- Dimensions $w \times h$: 740 x 310 mm.

Item No.	Description	Price HRK
850.314	Microsurf	



Roughness specimens in a set



850.130

This set consists of 30 specimens, mounted in a practical case with instruction card. In addition to the R_a values, the standardized N values and the R_z values are specified.

MedioTehna

Set composition

Item No.	Language	Price HRK
850.130	English	
850.131	French	
850.132	German	

Available with declaration of conformity on request.

Number of specimens	Machining method	Roughness $R_a/\mu\text{m}$	Roughness class N
3	Flat lapping	0.05 - 0.2	2, 3, 4
3	Reaming	0.4 - 1.6	5, 6, 7
6	Grinding	0.05 - 1.6	2, 3, 4, 5, 6, 7
6	Horizontal milling	0.4 - 12.5	5, 6, 7, 8, 9, 10
6	Vertical milling	0.4 - 12.5	5, 6, 7, 8, 9, 10
6	Turning	0.4 - 12.5	5, 6, 7, 8, 9, 10

Roughness specimens for blasted surfaces

- Each plate consists of four roughness specimens for grit and shot blasting, in 4 segments.
- Delivered in a soft case.
- Standardized to ISO specifications.



Item No.	Description	Price HRK
850.017	Shot blasting	
850.018	Grit blasting	

Gauge blocks / Measuring balls / Optical flats and parallel optical flats / Feeler gauges



Gauge blocks general

Which gauge block is the most suitable for you?

MedioTehna

MATERIALS

Steel

Steel is the oldest material and remains the most commonly accepted for gauge blocks. If well taken care of, steel gauges guarantee many years of useful life. They must be cleaned carefully before and after use and stored in a protective case in a dry environment.

Tungsten carbide

When a higher degree of hardness is needed, tungsten carbide is the material to choose. It is less sensitive to wear and damage compared to hardened steel. Especially when used frequently, tungsten carbide has an increased life span compared to steel gauge blocks.

Ceramics

Ceramics is relatively wear resistant and has a high degree of strength and stability. It will not rust and is unaffected by chemicals.

Class 2

Class 2 gauge blocks are intended for general workshop use by skilled workers to set up, for example, measuring instruments.

Class 1

Class 1 gauge blocks are used as working standards in inspection rooms within the production to set and calibrate measuring instruments and equipment as well as to inspect tools, fixtures and machines.

Class 0

Class 0 gauge blocks, with their high accuracy, are intended for use by measuring technicians in environmentally controlled inspection rooms, for example to calibrate measuring equipments.

Class K

Class K gauge blocks have the highest class of accuracy. They are *the* length standards in a calibration laboratory and other calibration values are derived from these gauges. Only with a UKAS certificate – or with another certificate, accepted by UKAS as equivalent (e.g. DAkkS, RvA and COFRAC) – will these gauge blocks be at their best. The most accurate gauges can meet a tolerance of $\pm 0.05 \mu\text{m}$.

ACCURACY CLASSES

Gauge blocks are classified in upgrading order of accuracy according to EN ISO 3650: 1998 in the classes: 2, 1, 0, K. The ISO 3650 is an international standard, which is adopted by national standards such as RvA, DAkkS, UKAS, BKO, SCS and COFRAC.

Accuracy according ISO 3650

Nominal size mm	Class K		Class 0		Class 1		Class 2	
	Tolerance on nominal size μm	Deviation* μm	Tolerance on nominal size μm	Deviation* μm	Tolerance on nominal size μm	Deviation* μm	Tolerance on nominal size μm	Deviation* μm
0.5 - 10	± 0.20	0.05	± 0.12	0.10	± 0.20	0.16	± 0.45	0.30
10 - 25	± 0.30	0.05	± 0.14	0.10	± 0.30	0.16	± 0.60	0.30
25 - 50	± 0.40	0.06	± 0.20	0.10	± 0.40	0.18	± 0.80	0.30
50 - 75	± 0.50	0.06	± 0.25	0.12	± 0.50	0.18	± 1.00	0.35
75 - 100	± 0.60	0.07	± 0.30	0.12	± 0.60	0.20	± 1.20	0.35
100 - 150	± 0.80	0.08	± 0.40	0.14	± 0.80	0.20	± 1.60	0.40
150 - 200	± 1.00	0.09	± 0.50	0.16	± 1.00	0.25	± 2.00	0.40
200 - 250	± 1.20	0.10	± 0.60	0.16	± 1.20	0.25	± 2.40	0.45
250 - 300	± 1.40	0.10	± 0.70	0.18	± 1.40	0.25	± 2.80	0.50
300 - 400	± 1.80	0.12	± 0.90	0.20	± 1.80	0.30	± 3.60	0.50
400 - 500	± 2.20	0.14	± 1.10	0.25	± 2.20	0.35	± 4.40	0.60
500 - 600	± 2.60	0.16	± 1.30	0.25	± 2.60	0.40	± 5.00	0.70
600 - 700	± 3.00	0.18	± 1.50	0.30	± 3.00	0.45	± 6.00	0.70
700 - 800	± 3.40	0.20	± 1.70	0.30	± 3.40	0.50	± 6.50	0.80
800 - 900	± 3.80	0.20	± 1.90	0.35	± 3.80	0.50	± 7.50	0.90
900 - 1000	± 4.20	0.25	± 2.00	0.40	± 4.20	0.60	± 8.00	1.00

* Deviation of the measuring face.

Steel gauge blocks

Steel gauge blocks with an excellent price-performance ratio.

- Hardness: 63 - 65 HRC.
- Expansion coefficient: $(11.5 \pm 1) \cdot 10^{-6} / ^\circ\text{C}$.
- Cross-section: 0.5 - 10 mm: 30 x 9 mm,
> 10 mm: 35 x 9 mm.
- ISO 3650.
- Sets delivered with a manufacturer measuring report.
- Delivery in plastic case and sets in wooden case.
- Empty wooden cases with cutouts and size indications for gauge block sets are optionally available. For these cases see wooden cases for gauge block sets elsewhere in the catalog.

MedioTehna



Steel gauge blocks in sets

Item No.	Class	Price HRK	Size mm	Increment mm	Pieces
M32:			1.005	–	1
906.622	2		1.01 - 1.09	0.01	9
906.621	1		1.1 - 1.9	0.1	9
906.620	0		1 - 9	1	9
			10 - 30	10	3
			50	–	1
M47:			1.005	–	1
906.625	2		1.01 - 1.09	0.01	9
906.624	1		1.1 - 1.9	0.1	9
906.623	0		1 - 24	1	24
			25 - 100	25	4
M87:			1.001 - 1.009	0.001	9
906.613	2		1.01 - 1.49	0.01	49
906.612	1		0.5 - 9.5	0.5	19
906.611	0		10 - 100	10	10
M88:			1.0005	–	1
906.628	2		1.001 - 1.009	0.001	9
906.627	1		1.01 - 1.49	0.01	49
906.626	0		0.5 - 9.5	0.5	19
			10 - 100	10	10
M112:			1.0005	–	1
906.631	2		1.001 - 1.009	0.001	9
906.630	1		1.01 - 1.49	0.01	49
906.629	0		0.5 - 24.5	0.5	49
			25 - 100	25	4

Steel gauge blocks, per piece

Size mm	Increment mm	ISO 3650/1 Price HRK	ISO 3650/0 Price HRK
0.5	–		
1	–		
1.0005	–		
1.001 - 1.009	0.001		
1.01 - 1.50	0.01		
1.6 - 2.0	0.1		
2.5 - 7.5	0.5		
8.0 - 10.0	0.5		
10.5 - 25.0	0.5		
30	–		
40	–		
50	–		
60	–		
70	–		
75	–		
80	–		
90	–		
100	–		

Select steel gauge blocks

High quality steel gauge blocks, can be very well wringed to make a combination size. The steel gauge blocks are available in all accuracy classes of ISO 3650 (2, 1, 0, K). Only the most commonly used sizes can be found in this catalog. Special sizes and sets are available on request, as well as special sets for calibration of micrometers and calipers.

- Hardness: approx. 800 HV.
- Expansion coefficient: $\alpha = 11.5 \cdot 10^{-6} \text{ K}^{-1}$.
- Cross-section: 0.5 - 10 mm: 30 x 9 mm,
> 10 mm: 35 x 9 mm.
- ISO 3650.

- Delivery with a traceable manufacturer measuring report.
- Delivery on request with a DAkkS certificate, UKAS acknowledged.
- Sets delivered in luxurious wooden case.
- Plastic cases for separate gauge blocks are optionally available. For these cases see plastic cases for gauge blocks elsewhere in the catalog.



Steel gauge blocks, per piece

Size mm	Increment mm	ISO 3650/1 Price HRK	ISO 3650/0 Price HRK
0.5	–		
1	–		
1.0005	–		
1.001 - 1.009	0.001		
1.01 - 1.5	0.01		
1.6 - 1.9	0.1		
2.0 - 5.5	0.5		
6.0 - 10.0	0.5		
10.5 - 15.0	0.5		
15.5 - 20.0	0.5		
20.5 - 25.0	0.5		
30	–		
40	–		
50	–		
60	–		
70	–		
75	–		
80	–		
90	–		
100	–		

Steel gauge blocks in sets

Item No.	Class	Price HRK	Size mm	Increment mm	Pieces
M32:					
831.915	1		1.005	–	1
			1.01 - 1.09	0.01	9
831.914	0		1.1 - 1.9	0.1	9
			1 - 9	1	9
			10 - 30	10	3
			50	–	1
M47:					
831.911	1		1.005	–	1
			1.00 - 1.09	0.01	10
831.910	0		1.1 - 1.9	0.1	9
			2 - 25	1	24
			50 - 100	25	3
M87:					
831.909	1		0.5	–	1
			1.001 - 1.009	0.001	9
831.908	0		1.00 - 1.50	0.01	51
			2.0 - 10.0	0.5	17
			20 - 100	10	9
M103:					
831.907	1		0.5	–	1
			1.005	–	1
831.906	0		1.00 - 1.50	0.01	51
			2.0 - 25.0	0.5	47
			50 - 100	25	3
M112:					
831.905	1		0.5	–	1
			1.0005	–	1
831.904	0		1.001 - 1.009	0.001	9
			1.00 - 1.50	0.01	51
			2.0 - 25.0	0.5	47
			50 - 100	25	3
M122:					
831.903	1		0.5	–	1
			1.0005	–	1
831.902	0		1.001 - 1.009	0.001	9
			1.00 - 1.50	0.01	51
			1.6 - 1.9	0.1	4
			2.0 - 25.0	0.5	47
			30 - 70	10	5
			75	–	1
			80 - 100	10	3

Tungsten carbide gauge blocks

Tungsten carbide gauge blocks with an excellent price-performance ratio and a low expansion coefficient. High resistance against corrosion.

- Hardness: 70-72 HRC.
- Expansion coefficient: $(8.5 \pm 1) \cdot 10^{-6}/^{\circ}\text{C}$.
- Cross-section: 0.5-10 mm: 30 x 9 mm,
>10 mm: 35 x 9 mm.
- ISO 3650.
- Sets delivered with a manufacturer measuring report.
- Delivery in plastic case and sets in wooden case.
- Empty wooden cases with cutouts and size indications for gauge block sets are optionally available. For these cases see wooden cases for gauge block sets elsewhere in the catalog.

MedioTehna

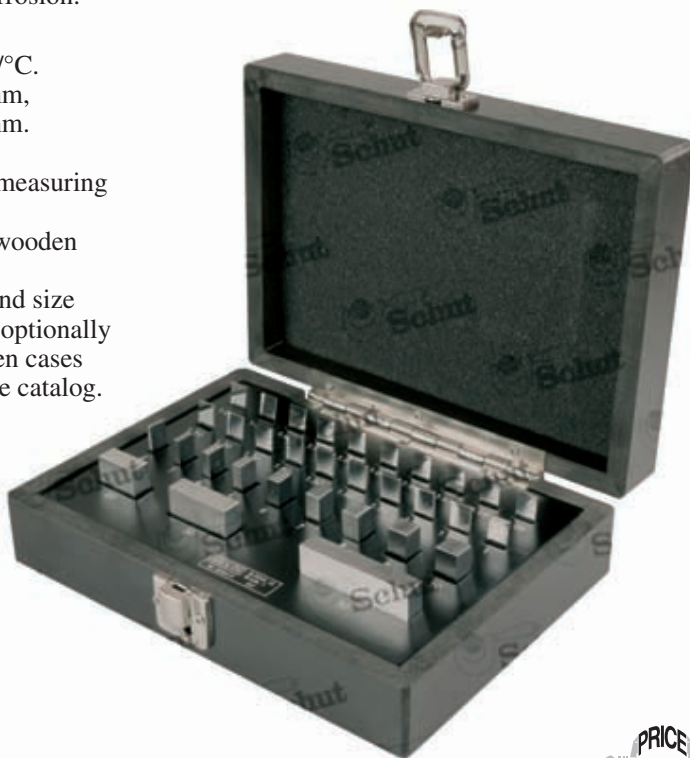

Tungsten carbide gauge blocks, per piece

Size mm	Increment mm	ISO 3650/1 Price HRK	ISO 3650/0 Price HRK
0.5	–		
1	–		
1.0005	–		
1.001 - 1.009	0.001		
1.01 - 1.50	0.01		
1.6 - 1.9	0.1		
2.0 - 10.0	0.5		
10.5 - 15.0	0.5		
15.5 - 25.0	0.5		
30	–		
40	–		
50	–		
60	–		
70	–		
75	–		
80	–		
90	–		
100	–		

Tungsten carbide gauge blocks in sets

Item No.	Class	Price HRK	Size mm	Increment mm	Pieces
M32:			1.005	–	1
906.634	2		1.01 - 1.09	0.01	9
906.633	1		1.1 - 1.9	0.1	9
906.632	0		1 - 9	1	9
			10 - 30	10	3
			50	–	1
M47:			1.005	–	1
906.637	2		1.01 - 1.09	0.01	9
906.636	1		1.1 - 1.9	0.1	9
906.635	0		1 - 24	1	24
			25 - 100	25	4
M87:			1.001 - 1.009	0.001	9
906.662	2		1.01 - 1.49	0.01	49
906.661	1		0.5 - 9.5	0.5	19
906.660	0		10 - 100	10	10
M112:			1.0005	–	1
906.643	2		1.001 - 1.009	0.001	9
906.642	1		1.01 - 1.49	0.01	49
906.641	0		0.5 - 24.5	0.5	49
			25 - 100	25	4

PRICE

Select tungsten carbide gauge blocks

High quality tungsten carbide gauge blocks, can be very well wringed to make a combination size. The tungsten carbide gauge blocks are available in all accuracy classes of ISO 3650 (2, 1, 0, K). Only the most commonly used sizes can be found in this catalog. Special sizes and sets are available on request.

- Hardness: approx. 1500 HV.
- Expansion coefficient: $\alpha = 4.5 \cdot 10^{-6} \text{ K}^{-1}$.
- Cross-section: 0.5 - 10 mm: 30 x 9 mm,
> 10 mm: 35 x 9 mm.
- ISO 3650.
- Delivery with a traceable manufacturer measuring report.
- Delivery on request with a DAkkS certificate, UKAS acknowledged.

- Sets delivered in luxurious wooden case.
- Plastic cases for separate gauge blocks are optionally available. For these cases see plastic cases for gauge blocks elsewhere in the catalog.



MedioTehna

SELECT

Tungsten carbide gauge blocks, per piece

Size mm	Increment mm	ISO 3650/1 Price HRK	ISO 3650/0 Price HRK
0.5	–		
1	–		
1.0005	–		
1.001 - 1.009	0.001		
1.01 - 1.50	0.01		
1.6 - 1.9	0.1		
2.0 - 5.5	0.5		
6.0 - 10.0	0.5		
10.5 - 15.0	0.5		
15.5 - 20.0	0.5		
20.5 - 25.0	0.5		
30	–		
40	–		
50	–		
60	–		
70	–		
75	–		
80	–		
90	–		
100	–		

Tungsten carbide gauge blocks in sets

Item No.	Class	Price HRK	Size mm	Increment mm	Pieces
M32:					
828.592	1		1.005	–	1
828.606	0		1.01 - 1.09	0.01	9
			1.1 - 1.9	0.1	9
			1 - 9	1	9
			10 - 30	10	3
			50	–	1
M46:					
828.590	1		1.001 - 1.009	0.001	9
828.604	0		1.00 - 1.09	0.01	10
			1.1 - 1.9	0.1	9
			2 - 10	1	9
			20 - 100	10	9
M47:					
828.589	1		1.005	–	1
828.603	0		1.00 - 1.09	0.01	10
			1.1 - 1.9	0.1	9
			2 - 25	1	24
			50 - 100	25	3
M87:					
828.587	1		0.5	–	1
828.601	0		1.001 - 1.009	0.001	9
			1.00 - 1.50	0.01	51
			2.0 - 10.0	0.5	17
			20 - 100	10	9
M103:					
828.585	1		0.5	–	1
828.599	0		1.005	–	1
			1.00 - 1.50	0.01	51
			2.0 - 25.0	0.5	47
			50 - 100	25	3
M112:					
828.584	1		0.5	–	1
828.598	0		1.0005	–	1
			1.001 - 1.009	0.001	9
			1.00 - 1.50	0.01	51
			2.0 - 25.0	0.5	47
			50 - 100	25	3
M122:					
828.583	1		0.5	–	1
828.597	0		1.0005	–	1
			1.001 - 1.009	0.001	9
			1.00 - 1.50	0.01	51
			1.6 - 1.9	0.1	4
			2.0 - 25.0	0.5	47
			30 - 70	10	5
			75	–	1
			80 - 100	10	3

Ceramic gauge blocks

Ceramic gauge blocks with an excellent price-performance ratio, made of Zirconia ceramics. Because of this, these gauge blocks are highly durable, corrosion proof and completely stable for long-term use.

- Highly wear-resistant. Can be used 5 to 10 times longer than steel gauge blocks.
- Rustproof.



- Hardness: 88-90 HRC.
- Expansion coefficient: $(9.2 \pm 1) \cdot 10^{-6} / ^\circ\text{C}$.
- Cross-section: 0.5-10 mm: 30 x 9 mm, >10 mm: 35 x 9 mm.
- ISO 3650.
- Sets delivered with a manufacturer measuring report.
- Delivery in plastic case and sets in wooden case.
- Empty wooden cases with cutouts and size indications for gauge block sets are optionally available. For these cases see wooden cases for gauge block sets elsewhere in the catalog.

MedioTehna

Ceramic gauge blocks, per piece

Size mm	Increment mm	ISO 3650/1 Price HRK	ISO 3650/0 Price HRK
0.5	–		
1	–		
1.0005	–		
1.001 - 1.009	0.001		
1.01 - 1.49	0.01		
1.5 - 1.9	0.1		
2.0 - 5.5	0.5		
6.0 - 9.5	0.5		
10.0 - 20.0	0.5		
20.5 - 25.0	0.5		
30	–		
40	–		
50	–		
60	–		
70	–		
75	–		
80	–		
90	–		
100	–		

Ceramic gauge blocks in sets

Item No.	Class	Price HRK	Size mm	Increment mm	Pieces
M32:			1.005	–	1
906.646	1		1.01 - 1.09	0.01	9
906.645	0		1.1 - 1.9	0.1	9
			1 - 9	1	9
			10 - 30	10	3
			50	–	1
M47:			1.005	–	1
906.649	1		1.01 - 1.09	0.01	9
906.648	0		1.1 - 1.9	0.1	9
			1 - 24	1	24
			25 - 100	25	4
M87:			1.001 - 1.009	0.001	9
906.652	1		1.01 - 1.49	0.01	49
906.651	0		0.5 - 9.5	0.5	19
			10 - 100	10	10
M103:			1.005	–	1
906.655	1		1.01 - 1.49	0.01	49
906.654	0		0.5 - 24.5	0.5	49
			25 - 100	25	4
M112:			1.0005	–	1
906.658	1		1.001 - 1.009	0.001	9
906.657	0		1.01 - 1.49	0.01	49
			0.5 - 24.5	0.5	49
			25 - 100	25	4

PRICE

Select ceramic gauge blocks

High quality ceramic gauge blocks, can be very well wringed to make a combination size. The ceramic gauge blocks are available in all accuracy classes of ISO 3650 (2, 1, 0, K). Only the most commonly used sizes can be found in this catalog. Special sizes and sets are available on request, as well as special sets for calibration of micrometers and calipers.

- Hardness: approx. 1350 HV.
- Expansion coefficient: $\alpha = 9.3 \cdot 10^{-6} \text{ K}^{-1}$.
- Cross-section: 0.5 - 10 mm: 30 x 9 mm,
> 10 mm: 35 x 9 mm.
- ISO 3650.
- Delivery with a traceable manufacturer measuring report.
- Delivery on request with a DAkkS certificate, UKAS acknowledged.
- Sets delivered in luxurious wooden case.
- Plastic cases for separate gauge blocks are optionally available. For these cases see plastic cases for gauge blocks elsewhere in the catalog.



MedioTehna

SELECT/

Ceramic gauge blocks, per piece

Size mm	Increment mm	ISO 3650/1 Price HRK	ISO 3650/0 Price HRK
0.5	–		
1	–		
1.0005	–		
1.001 - 1.009	0.001		
1.01 - 1.50	0.01		
1.6 - 1.9	0.1		
2.0 - 5.5	0.5		
6.0 - 10.0	0.5		
10.5 - 15.0	0.5		
15.5 - 20.0	0.5		
20.5 - 25.0	0.5		
30	–		
40	–		
50	–		
60	–		
70	–		
75	–		
80	–		
90	–		
100	–		

Ceramic gauge blocks in sets

Item No.	Class	Price HRK	Size mm	Increment mm	Pieces
M32:					
831.085	1		1.005	–	1
			1.01 - 1.09	0.01	9
831.084	0		1.1 - 1.9	0.1	9
			1 - 9	1	9
			10 - 30	10	3
			50	–	1
M47:					
831.081	1		1.005	–	1
			1.00 - 1.09	0.01	10
831.080	0		1.1 - 1.9	0.1	9
			2 - 25	1	24
			50 - 100	25	3
M87:					
831.079	1		0.5	–	1
			1.001 - 1.009	0.001	9
831.078	0		1.00 - 1.50	0.01	51
			2.0 - 10.0	0.5	17
			20 - 100	10	9
M103:					
831.077	1		0.5	–	1
			1.005	–	1
831.076	0		1.00 - 1.50	0.01	51
			2.0 - 25.0	0.5	47
			50 - 100	25	3
M112:					
831.075	1		0.5	–	1
			1.0005	–	1
831.074	0		1.001 - 1.009	0.001	9
			1.00 - 1.50	0.01	51
			2.0 - 25.0	0.5	47
			50 - 100	25	3
M122:					
831.073	1		0.5	–	1
			1.0005	–	1
831.072	0		1.001 - 1.009	0.001	9
			1.00 - 1.50	0.01	51
			1.6 - 1.9	0.1	4
			2.0 - 25.0	0.5	47
			30 - 70	10	5
			75	–	1
			80 - 100	10	3

Long gauge blocks from 125 mm

Long steel gauge blocks with an excellent price-performance ratio. These steel gauge blocks are available in the accuracy classes 0, 1 and 2 of ISO 3650. All gauge blocks have two coupling holes on both ends so that they can be coupled by means of a toggle clamp.

- Hardness: 63 - 65 HRC.
- Expansion coefficient: $(11.5 \pm 1) \cdot 10^{-6}/^{\circ}\text{C}$.
- Cross-section: 35 x 9 mm.
- ISO 3650.
- Delivery in wooden case with a manufacturer measuring report.



907.741



907.707

MedioTehna



Size/mm	Item No.	Price HRK	Item No.	Price HRK	Item No.	Price HRK
	ISO 3650/2:		ISO 3650/1:		ISO 3650/0:	
125	907.728		907.715		907.702	
150	907.729		907.716		907.703	
175	907.730		907.717		907.704	
200	907.731		907.718		907.705	
250	907.732		907.719		907.706	
300	907.733		907.720		907.707	
400	907.734		907.721		907.708	
500	907.735		907.722		907.709	
600	907.736		907.723		907.710	
700	907.737		907.724		907.711	
800	907.738		907.725		907.712	
900	907.739		907.726		907.713	
1000	907.740		907.727		907.714	
Gauge block set consisting of 125, 150, 175, 200, 250, 300, 400 and 500 mm:						
	907.743		907.742		907.741	
Gauge block set consisting of 600, 700, 800, 900 and 1000 mm:						
	907.746		907.745		907.744	

Select long gauge blocks from 125 mm

High quality long steel gauge blocks. These steel gauge blocks are available in the accuracy classes 0, 1 and 2 of ISO 3650. All gauge blocks have two coupling holes on both ends so that they can be coupled by means of a toggle clamp.

- Hardness: approx. 800 HV.
- Expansion coefficient: $\alpha = 11.5 \cdot 10^{-6} \text{ K}^{-1}$.
- Cross-section: 35 x 9 mm.
- ISO 3650.
- Delivery in a luxurious wooden case with a traceable manufacturer measuring report.
- Delivery on request with a DAkkS certificate, UKAS acknowledged.
- Gauge blocks of 1000 - 1500 mm incl. a DAkkS certificate, UKAS acknowledged available on request.



MedioTehna

SELECT

Size/mm	Item No.	Price HRK	Item No.	Price HRK	Item No.	Price HRK
	ISO 3650/2:		ISO 3650/1:		ISO 3650/0:	
125	831.019		831.008		831.000	
150	831.020		831.009		831.001	
175	831.021		831.010		831.002	
200	831.022		831.011		831.003	
250	831.023		831.012		831.936	
300	831.024		831.013		831.937	
400	831.025		831.981		831.946	
500	831.026		831.738		831.004	
600	831.027		831.014		831.947	
700	831.028		831.015		831.005	
800	831.029		831.016		831.948	
900	831.030		831.017		831.006	
1000	831.031		831.018		831.007	
Gauge block set consisting of 125, 150, 175, 200, 250, 300, 400 and 500 mm:						
	831.088		831.087		831.086	
Gauge block set consisting of 600, 700, 800, 900 and 1000 mm:						
	831.091		831.090		831.089	

Toggle clamp for long series gauge blocks

Toggle clamp for the coupling of gauge blocks over 100 mm which have coupling holes on both ends. Very quick assembly by means of spring clamping device (with locking screw).

Item No.	Description	Price HRK
619.031	Toggle clamp for long series gauge blocks	



Caliper inspection set

For checking the accuracy of DIN 862 calipers. The set consists of three special steel gauge blocks (30 mm, 41.3 mm and 131.4 mm, ISO 3650 class 1), two steel setting rings (ø4 mm and ø25 mm) and a pair of gloves.

- Delivery in a wooden case with a manufacturer measuring report.

MedioTehna



Item No.	Description	Price HRK
909.347	Caliper inspection set	

Micrometer inspection sets

For the inspection of micrometers according DIN 863. Suitable for micrometers with a measuring range up to 25 mm.

- Nominal sizes (mm):
2.5 - 5.1 - 7.7 - 10.3 - 12.9 - 15.0 - 17.6 - 20.2 - 22.8 - 25.0.
- Including plan parallel optical flat ø30 x 12 mm.
- Delivery in a wooden case with a manufacturer measuring report.



909.340

Item No.	Material	Grade	Price HRK
909.346	steel	1	
909.345	steel	0	
909.162	ceramic	1	
909.340	ceramic	0	

Gauge block accessories

Various accessories to extract the resulting size of one or more gauge blocks outside or to convert it into an inside gauge. This also enables the creation of setting gauges and marking tools. These accessories considerably increase the applicability of standard gauge blocks.

MedioTehna



907.202



907.204



907.210



907.209



907.207

Item No. Description	Price HRK	Set		
		M8	M10	M12
Holder for gauge blocks:				
907.203 Up to 50 mm		•	•	•
907.204 Up to 100 mm		•	•	•
907.205 Up to 200 mm		•	•	•
Pair of measuring jaws, with measuring faces:				
907.206 Cylindrical \varnothing 2 mm and flat ($l=40$ mm)		•	•	•
907.207 Cylindrical \varnothing 5 mm and flat ($l=45$ mm)		•	•	•
907.208 Cylindrical \varnothing 10 mm and flat ($l=70$ mm)			•	•
907.209 Flat ($l=100$ mm, $h=19$ mm)			•	•
907.213 V-shaped ($l=60$ mm, max. \varnothing 60 mm)			•	•
907.210 Straight edge ($l=100$ mm)				•
907.211 Scriber ($l=45$ mm)		•	•	•
907.212 Center point ($l=45$ mm)		•	•	•
907.214 Base for holder ($h=25$ mm)		•	•	•
Accessory sets, delivered in a case:				
907.200 M8		↑		
907.201 M10			↑	
907.202 M12				↑



907.213



907.211

907.212

Holder for gauge blocks

Holder for gauge blocks for fixation of gauge blocks for serial inspection. Can also be used in combination with inspection sets for micrometers and calipers.

- Suited for use with 10 gauge blocks.
- Anodized aluminum with steel base and hard plastic clamping blocks.
- Thickness gauge block: 9 mm conform ISO 3650.
- Delivery in a plastic carrying case incl. Allen key.



Item No.	Description	Price HRK
910.192	Holder for gauge blocks	

Holder for gauge blocks

- Anodized aluminum.
- Thickness gauge block: 9 mm conform ISO 3650.



Item No.	Description	Price HRK
906.434	Holder for gauge blocks	

Select microfibre cleaning cloth

Microfibre cleaning cloth for gauge blocks. Ideal for measuring rooms.

- Dimensions: 22.5 x 22.5 cm.



Item No.	Description	Price HRK
831.739	Microfibre cleaning cloth	

Plastic cases for gauge blocks

Plastic cases with removeable foam inserts to store gauge blocks safely. Available in 3 sizes.



Item No.	Gauge blocks size/mm	Price HRK
906.998	0.50- 13.00	
906.999	13.50- 50.00	
908.808	60.00-100.00	

Wooden cases for gauge block sets

Wooden cases with cutouts and size indications for gauge block sets.



NEW



MedioTehna

Item No.	Price HRK	Size mm	Increment mm	Pieces
M32: 910.361		1.005	–	1
		1.01 - 1.09	0.01	9
		1.1 - 1.9	0.1	9
		1 - 9	1	9
		10 - 30	10	3
		50	–	1
M47: 910.362		1.005	–	1
		1.01 - 1.09	0.01	9
		1.1 - 1.9	0.1	9
		1 - 24	1	24
		25 - 100	25	4
M87: 910.363		1.001 - 1.009	0.001	9
		1.01 - 1.49	0.01	49
		0.5 - 9.5	0.5	19
		10 - 100	10	10
M88: 910.364		1.0005	–	1
		1.001 - 1.009	0.001	9
		1.01 - 1.49	0.01	49
		0.5 - 9.5	0.5	19
		10 - 100	10	10
M103: 910.365		1.005	–	1
		1.01 - 1.49	0.01	49
		0.5 - 24.5	0.5	49
		25 - 100	25	4
M112: 910.366		1.0005	–	1
		1.001 - 1.009	0.001	9
		1.01 - 1.49	0.01	49
		0.5 - 24.5	0.5	49
		25 - 100	25	4

Angle gauge block set

Set of twelve hardened steel angle gauge blocks, comprising the angles $1/4^\circ$ (15'), $1/2^\circ$ (30'), 1° , 2° , 3° , 4° , 5° , 10° , 15° , 20° , 25° and 30° . A combination of angle gauge blocks is possible.

- Accuracy: $\pm 30''$.
- Thickness gauge blocks: 6 mm.
- Delivery in a wooden case with a declaration of conformity.

MedioTehna



Item No.	Description	Price HRK
909.799	Angle gauge block set	



Steel measuring balls

Steel measuring balls for measuring e.g. internal tapers.

- Material: chrome alloy steel.
- Hardness: 63 HRC.
- Nominal dimension tolerance: $< 2.5 \mu\text{m}$.
- Roundness: $< 0.6 \mu\text{m}$.
- Surface roughness: $< 0.05 \mu\text{m}$.
- Two balls of each size.
- Delivery with a declaration of conformity.
- Set 909.647: Delivery in a plastic case.

Item No.	Size mm	Number per size	Price HRK
910.224	1	2	
910.225	2	2	
910.226	3	2	
910.227	4	2	
910.228	5	2	
910.229	6	2	
910.230	7	2	
910.231	8	2	
910.232	9	2	
910.233	10	2	
910.234	11	2	
910.235	12	2	
910.237	13	2	
910.238	14	2	
910.239	15	2	
910.240	16	2	
910.241	17	2	
910.242	18	2	
910.243	19	2	
910.244	20	2	
910.245	21	2	
910.246	22	2	
910.247	23	2	
910.248	24	2	
910.249	25	2	



Set steel measuring balls

Item No.	Size mm	Incr. mm	Number per size	Total number	Price HRK
909.647	1 - 25	1	2	50	



Select optical flats

Optical flats can be used for inspection of the flatness of reflecting surfaces of for example gauge blocks, settings gauges and other lapped surfaces by optical interference.

- Flatness measuring faces: $\leq 0.10 \mu\text{m}$.
- Wedge angle error: $> 10.0'$ (optical flats, double sided).
- On request with a DAkkS certificate, UKAS acknowledged.
- Delivery in an aluminum case.

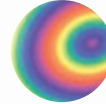
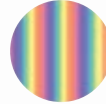
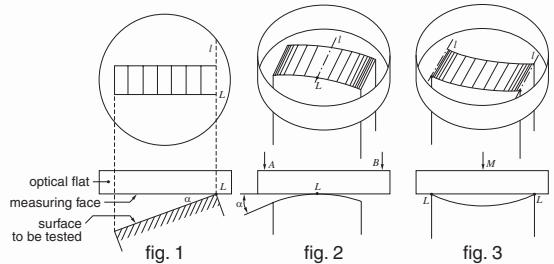

Item No.	Diameter mm	Thickness mm	Price HRK
Single optical flats, single sided:			
826.625	30	15	
826.626	45	15	
826.627	50	20	
826.628	60	20	
826.629	75	20	
Single optical flats, double sided:			
827.011	30	15	
826.631	45	15	
826.632	50	20	
826.633	60	20	
826.634	75	20	

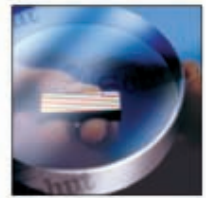

Select plan parallel optical flats

Plan parallel optical flats can be used for inspection of the parallelism and flatness of measuring surfaces of micrometers and other measuring instruments. Each set consists of 4 sizes plan parallel optical flats for inspection of micrometers on every fourth rotation of the spindle.

- For micrometers with a spindle pitch of 0.5 mm.
- Sets for micrometers with a measuring range of 0-25 mm, 25-50 mm, 50-75 mm and 75-100 mm.
- Diameter: 30 mm.
- On request with a DAkkS certificate, UKAS acknowledged.
- Delivery in an aluminum case.

826.635



Item No.	Thicknesses/mm	Flatness measuring faces:	Parallelism measuring faces:	Price HRK
826.635	12.00/12.12/12.25/12.37	$\leq 0.15 \mu\text{m}$	$\leq 0.3 \mu\text{m}$	
826.636	25.00/25.12/25.25/25.37	$\leq 0.15 \mu\text{m}$	$\leq 0.3 \mu\text{m}$	
827.873	50.00/50.12/50.25/50.37	$\leq 0.20 \mu\text{m}$	$\leq 0.5 \mu\text{m}$	
827.874	75.00/75.12/75.25/75.37	$\leq 0.20 \mu\text{m}$	$\leq 0.5 \mu\text{m}$	
Option:				
826.630	Single plan parallel optical flat, thickness 12.00 mm	$\leq 0.15 \mu\text{m}$	$\leq 0.3 \mu\text{m}$	

MedioTehna



Feeler gauges

Feeler gauge sets in a holder, for individual use or in combination to measure slits and gaps as well as checking the amount of clearance in sliding guides, bearings, pistons etc.

- Measuring range: 0.03 - 2.00 mm.
- Blade length: 100 mm.
- Nickel plated handle with locking screw.
- Blade width: 10 mm (except stainless steel models: 12 mm), tapered.
- Accuracy according DIN 2275 T2.
- Also available in brass model (anti-magnetic).

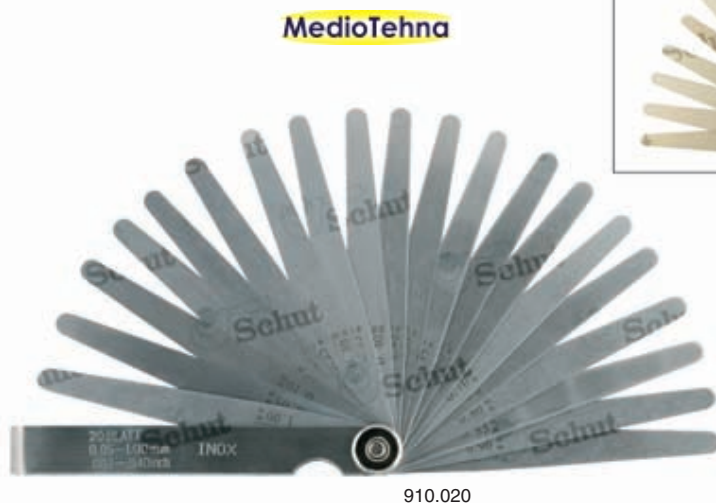

Item No.	Number of blades	Increment(s)				Material	Price HRK
		0.01 mm	0.02 mm	0.05 mm	0.10 mm		
909.904	8			0.05 → 0.30	0.40 → 0.50	hardened steel	
909.905	8			0.05 → 0.30	0.40 → 0.50	stainless steel	
909.906	8			0.05 → 0.30	0.40 → 0.50	brass	
909.907	13			0.05 → 0.30	0.40 → 1.00	hardened steel	
909.908	13			0.05 → 0.30	0.40 → 1.00	stainless steel	
909.909	13			0.05 → 0.30	0.40 → 1.00	brass	
910.019	20			0.05 → 1.00		hardened steel	
910.020	20			0.05 → 1.00		stainless steel	
910.021	20			0.05 → 1.00		brass	
910.022	8	0.03 → 0.10				hardened steel	
910.023	10	0.03 → 0.05		0.10 → 0.30	0.40 → 0.50	hardened steel	
910.024	10				0.10 → 1.00	hardened steel	
910.026	14	0.03 → 0.10		0.15 → 0.30	0.40 → 0.50	hardened steel	
910.027	18	0.05 → 0.10		0.15 → 0.40	0.50 → 1.00	hardened steel	
910.028	19	0.03 → 0.10		0.15 → 0.30	0.40 → 1.00	hardened steel	
910.029	20	0.04 → 0.10		0.15 → 0.50	0.60 → 1.00	hardened steel	
908.978	22	0.03 → 0.05		0.10 → 1.00		hardened steel	
908.979	28	0.03 → 0.10	0.12 → 0.50			hardened steel	
910.034	21			0.05 → 0.10	0.20 → 2.00	hardened steel	

Feeler gauges

- Measuring range: 0.05 - 2.00 mm;
20 blades: 0.05 / 0.10 → 1.00 (except 856.069:
20 blades: 0.10 / 0.10 → 2.00).
- Material: hardened steel.
- Blade width: 12.8 mm (except 856.069:
13.8 mm).



MedioTehna



910.031

Item No.	Blade length/mm	Price HRK
910.030	200	
910.031	300	
910.033	500	
856.069	200	

Feeler stock coils

Feeler stock coils made of steel.

- Measuring range: 0.005 - 1.00 mm.
- Length: 5 m.
- Width: 13 mm.
- Other widths or material (stainless steel or brass) available on request.



856.045



856.030



856.032

Item No.	Thickness/mm	Price HRK
856.036	0.005	
856.037	0.01	
856.038	0.02	
856.039	0.03	
856.040	0.04	
856.041	0.05	
856.042	0.06	
856.043	0.07	
856.044	0.08	
856.045	0.09	
856.046	0.10	
856.047	0.12	
856.048	0.15	
856.049	0.18	
856.050	0.20	
856.051	0.25	
856.052	0.30	
856.053	0.35	
856.054	0.40	
856.055	0.45	
856.056	0.50	
856.057	0.55	
856.058	0.60	
856.059	0.65	
856.060	0.70	
856.061	0.75	
856.062	0.80	
856.063	0.85	
856.064	0.90	
856.065	0.95	
856.066	1.00	

Options

Item No.	Description	Price HRK
856.030	Set 0.01 - 0.25 mm	
856.031	Set 0.3 - 1.00 mm	
856.032	Holder for feeler stock coils	

Gauges / Pin gauges / Thread and tolerance tables



LMW plug gauges

Manufactured according DIN 2245, 2246 and 2247. Available from 0.5 to 160 mm; up to 70 mm with Go and NoGo on one handle, over 70 mm in two parts. Prices are for H7 plug gauges with Go and NoGo ends in hardened steel.

- H7 fit size in hardened steel.
- Available from 0.5 to 160 mm; up to 70 mm with Go and NoGo on one handle, over 70 mm in two parts.
- Including wear allowance at the Go end.

Wear allowance

New gauges are supplemented with a wear allowance on the Go end: z (plus) for plug gauges. Accordingly, the size indicated on the handle is not similar to the measured value of the new Go end.

Example: plug gauge 20 H7

New Go end:

size	20.000 mm
wear allowance (+z)	<u>0.003 mm</u>
	20.003 mm
manufacturing tolerance	± 0.002 mm
largest value measured	20.005 mm
smallest value measured	20.001 mm

Also available:

- larger sizes,
- without wear allowance,
- many other fit sizes, like H6, H8, P7, G7 etc.,
- hard-chrome plated plug gauges,
- tungsten carbide plug gauges,
- extended plug gauges,
- plug gauges with vent hole,
- plug gauges with easy-entry pilot.

MedioTehna



Measuring reports

For all gauges also measuring reports can be ordered.

- ① Manufacturer measuring report (German) per gauge. Stating of product specifications, measured values after production, used traceable measuring devices, measuring inaccuracy and measuring date. A favourable choice when your quality system does not require traceable certificates.
- ② Traceable certificate (Dutch) with measuring reports of the ordered gauges. Besides stating of the measured values the extra assurance of an external inspection.

Size H7 mm	Price HRK	Size H7 mm	Price HRK	Size H7 mm	Price HRK	Size H7 mm	Price HRK	Size H7 mm	Price HRK
1		10		24		42		70	
1.5		11		25		44		72	
2		12		26		45		75	
2.5		13		27		46		78	
3		14		28		47		80	
3.5		15		30		48		82	
4		16		32		50		85	
4.5		17		33		52		88	
5		18		34		55		90	
5.5		19		35		58		92	
6		20		36		60		95	
7		21		37		62		98	
8		22		38		65		100	
9		23		40		68			

Larger sizes available on request.

Plug gauges H7

Manufactured according DIN EN ISO 1938. Available from 1 to 100 mm with Go and NoGo on one handle.

- DIN 7162 and 7164.
- H7 fit size in hardened steel.
- With serial number.
- Delivery with a manufacturer measuring report.
- Individual plug gauges delivered in a plastic tube. Set delivered in a plastic case.
- Including wear allowance at the Go end.

Wear allowance

New gauges are supplemented with a wear allowance on the Go end: z (plus) for plug gauges. Accordingly, the size indicated on the handle is not similar to the measured value of the new Go end.

MedioTehna



Item No.	Size H7 mm	Price HRK	Item No.	Size H7 mm	Price HRK	Item No.	Size H7 mm	Price HRK
911.000	1		911.023	19		911.047	47	
911.001	1.5		911.024	20		911.048	48	
911.002	2		911.025	21		911.049	50	
911.003	2.5		911.026	22		911.050	52	
911.004	3		911.027	23		911.051	55	
911.005	3.5		911.028	24		911.052	58	
911.006	4		911.029	25		911.053	60	
911.007	4.5		911.030	26		911.054	62	
911.008	5		911.031	27		911.055	65	
911.009	5.5		911.032	28		911.056	68	
911.010	6		911.033	30		911.057	70	
911.011	7		911.034	32		911.058	72	
911.012	8		911.035	33		911.059	75	
911.013	9		911.036	34		911.060	78	
911.014	10		911.037	35		911.061	80	
911.015	11		911.038	36		911.062	82	
911.016	12		911.039	37		911.063	85	
911.017	13		911.040	38		911.064	88	
911.018	14		911.041	40		911.065	90	
911.019	15		911.042	42		911.066	92	
911.020	16		911.043	44		911.067	95	
911.021	17		911.044	45		911.068	98	
911.022	18		911.045	46		911.069	100	

Set plug gauges

Item No.	Description	Price HRK
911.157	Plug gauges (Go + NoGo) H7: 3, 4, 5, 6, 8, 10, 12 mm	

Plug gauges G7

Manufactured according DIN 7162. Available from 1 to 20 mm; with Go and NoGo on one handle.

- DIN 7162.
- G7 fit size in hardened steel.
- Available from 1 to 20 mm; with Go and NoGo on one handle.
- With serial number.
- Delivery in a plastic tube with a manufacturer measuring report.
- Including wear allowance at the Go end.

Wear allowance

New gauges are supplemented with a wear allowance on the Go end: z (plus) for plug gauges. Accordingly, the size indicated on the handle is not similar to the measured value of the new Go end.



MedioTehna



Item No.	Size G7 mm	Price HRK
911.158	1	
911.159	1.5	
911.160	2	
911.161	2.5	
911.162	3	
911.163	3.5	
911.164	4	
911.165	4.5	
911.166	5	
911.167	5.5	
911.168	6	
911.169	7	
911.170	8	
911.171	9	
911.172	10	
911.173	11	
911.174	12	
911.175	13	
911.176	14	
911.177	15	
911.178	16	
911.179	17	
911.180	18	
911.181	19	
911.182	20	

NEW

Pin gauges in sets

Hardened steel pin gauges in sets with favourable price-performance ratio, very well suited for workshop use. Delivery in plastic case with a declaration of conformity and holder for Go/NoGo determination.

- Hardened steel.
- Diameter range: 0.20-20.00 mm.
- Increment: 0.01 mm or 0.1 mm.
- Accuracy: ± 0.003 mm.
- Without handle.
- Pin gauges $> \phi 1.5$ mm with size indication.
- Length: 50 mm.
- Delivery in a plastic carrying case with a declaration of conformity with pin gauges in separate plastic tubes with size indication.
- Delivery with holder with Go/NoGo indication.

NEW



Item No.	Diameter mm	Increment mm	Number per set	Price HRK
910.367	0.20-10.00	0.1	99	
910.368	10.00-20.00	0.1	101	
910.193	0.50- 1.00	0.01	51	
910.194	1.00- 2.00	0.01	101	
910.195	2.00- 3.00	0.01	101	
910.196	3.00- 4.00	0.01	101	
910.197	4.00- 5.00	0.01	101	
910.198	5.00- 6.00	0.01	101	
910.199	6.00- 7.00	0.01	101	
910.200	7.00- 8.00	0.01	101	
910.201	8.00- 9.00	0.01	101	
910.202	9.00-10.00	0.01	101	
910.203	10.00-11.00	0.01	101	
910.204	11.00-12.00	0.01	101	
910.205	12.00-13.00	0.01	101	
910.206	13.00-14.00	0.01	101	
910.207	14.00-15.00	0.01	101	
910.208	15.00-16.00	0.01	101	
910.209	16.00-17.00	0.01	101	
910.210	17.00-18.00	0.01	101	
910.211	18.00-19.00	0.01	101	
910.212	19.00-20.00	0.01	101	

910.195



910.213

Holders for Go/NoGo determination:

- 910.213 Pin gauge handle
Go-NoGo 0.5-13 mm
- 910.214 Pin gauge handle
Go-NoGo 13-20 mm

Holders for Go/NoGo determination:

- 910.378 0.30- 1.50
- 910.379 1.20- 6.50
- 910.380 5.00-14.00
- 910.381 12.00-16.50
- 910.382 14.00-19.50
- 910.383 18.00-22.00

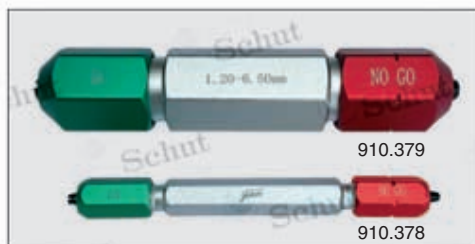

910.379

910.378

Pin gauges

Swiss made, hardened and ground steel pin gauges, conforms to DIN 2269; available separately and in sets.

- Hardened, ground, and seasoned steel (HV 760 ± 50).
- Diameter range:
 - without handle: 0.06 - 20.00 mm,
 - with handle: 0.06 - 10.00 mm.
- Increment: 0.01 mm.
- Accuracy: ±0.0015 mm.
- Pin gauges ø 5.00 - 20.00 mm without handle: indication on head.



Also available:

With an accuracy of ±0.0003 or ±0.001 mm;
 – hardened steel ø 0.06 - 20.00 mm,
 – tungsten carbide or ceramics ø 0.50 - 9.99 mm,
 with 0.01 mm increments. The length may deviate. More information available on request.

Diameter/mm	Length/mm	Price HRK
Pin gauge without handle:		
0.06 - 0.09 ¹	30	
0.10 - 0.19 ¹	40	
0.20 - 0.29 ¹	40	
0.30 - 0.49 ¹	40	
0.50 - 0.99 ¹	40	
1.00 - 2.99	70	
3.00 - 4.00	70	
4.01 - 5.00	70	
5.01 - 5.99	70	
6.00 - 9.99	70	
10.00 - 11.99	70	
12.00 - 13.99	70	
14.00 - 15.99	70	
16.00 - 18.99	70	
19.00 - 20.00	70	
Pin gauge with handle²:		
0.06 - 0.09 ¹	23	
0.10 - 0.19 ¹	33	
0.20 - 0.29 ¹	33	
0.30 - 0.49 ¹	33	
0.50 - 0.99 ¹	33	
1.00 - 2.99	62	
3.00 - 4.00	62	
4.01 - 5.00	62	
5.01 - 5.99	62	
6.00 - 10.00	62	

¹ Delivered in a plastic transport case.

² The length here indicates the measuring length and not the total length of the pin gauges.

Item No.	Description	Price HRK
Wooden case (tubes not included):		
833.211	For 50 pin gauges ø 0.10 - 10.00 mm without handle	
833.704	For 100 pin gauges ø 0.10 - 10.00 mm without handle	
833.264	For 50 pin gauges ø 0.10 - 10.00 mm with handle	
833.118	For 40 pin gauges ø 10.01 - 15.00 mm	
833.705	For 80 pin gauges ø 10.01 - 15.00 mm	
833.706	For 30 pin gauges ø 15.01 - 20.00 mm	
Plastic tubes for pin gauges¹:		
833.066	Without handle up to ø 0.99 mm	
838.224	Without handle ø 1.00 - 7.00 mm	
838.089	With handle up to ø 0.99 mm	

¹ For insert in wooden case.

MedioTehna



Pin gauges without handle in sets

- Hardened, ground, and seasoned steel (HV 760±50).
- Diameter range: 0.10- 10.00 mm.
- Increment: 0.01 mm.
- Accuracy: ±0.0015 mm.
- Pin gauges ϕ 5.00- 10.00 mm: indication on head.
- Length: ϕ 0.10- 0.99 mm: 40 mm,
 ϕ 1.00- 10.00 mm: 70 mm.
- Sets with larger diameters and/or with handle are available on request.



Item No.	Diameter mm	Increment mm	Number per set	Price* HRK
833.901	0.10- 1.00	0.01	91	
833.902	1.00- 2.00	0.01	101	
833.903	2.00- 3.00	0.01	101	
833.904	3.00- 4.00	0.01	101	
833.905	4.00- 5.00	0.01	101	
833.906	5.00- 6.00	0.01	101	
833.907	6.00- 7.00	0.01	101	
833.908	7.00- 8.00	0.01	101	
833.909	8.00- 9.00	0.01	101	
833.910	9.00-10.00	0.01	101	
834.190	1.00-10.00	0.10	91	

* Prices per set, in a wooden case.

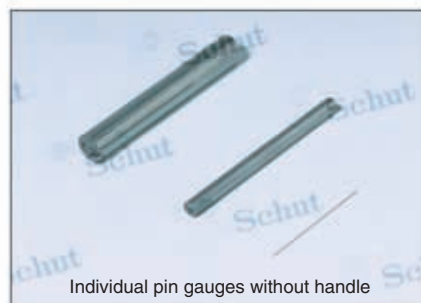

Pin gauges accessories

Interchangeable handles

- For pin gauges without handle.



Item No.	For diameter/mm	Price HRK
836.043	0.40-0.80	
834.172	0.80-1.30	
836.044	1.30-1.80	
836.045	1.80-2.30	
837.615	2.30-2.80	
837.956	2.80-3.30	
837.957	3.30-3.80	
837.958	3.80-4.30	
837.959	4.30-4.80	
837.960	4.80-5.30	

Holders for Go/NoGo determination

- For two pin gauges without handle.
- With NoGo indication.



Item No.	For diameter/mm	Price HRK
833.310	1.00- 2.00	
833.311	2.00- 4.00	
833.312	4.00- 6.00	
833.313	6.00- 8.00	
833.314	8.00-10.00	

MedioTehna

SWISS
MADE

Plug gauges

Ground and lapped, hardened tool steel plug gauges with a high accuracy. Available per piece and in sets. Swiss made.

- Diameter range: \varnothing 0.06 - 10.00 mm.
- Increment: 0.01 mm.
- Accuracy: \pm 0.0005 mm.
- Hardened tool steel (HV 760 \pm 50).
Ground and lapped.
- Measuring length (and total length):
 \varnothing 0.06 - 0.30 mm: 2 mm (34 mm),
 \varnothing 0.31 - 0.50 mm: 3.5 mm (35.5 mm),
 \varnothing 0.51 - 1.50 mm: 5 mm (37 mm),
 \varnothing 1.51 - 2.00 mm: 6 mm (38 mm),
 \varnothing 2.01 - 3.50 mm: 8 mm (43 mm),
 \varnothing 3.51 - 6.00 mm: 10 mm (55 mm),
 \varnothing 6.01 - 8.00 mm: 14 mm (59 mm),
 \varnothing 8.01 - 10.00 mm: 18 mm (63 mm).
- Size indication on the insulated handle.
- Also available in tungsten carbide and ceramic with an accuracy of \pm 0.001 mm.



Per piece

Diameter/mm	Price HRK
0.06- 0.09	
0.10- 0.19	
0.20- 0.29	
0.30- 0.49	
0.50- 0.99	
1.00- 2.99	
3.00- 5.99	
6.00-10.00	

Sets

Item No.	Diameter mm	Pieces	Price HRK
833.761	0.06- 0.50	45	
833.762	0.51- 1.00	50	
833.763	1.01- 1.50	50	
833.764	1.51- 2.00	50	
833.765	2.01- 2.50	50	
833.766	2.51- 3.00	50	
833.767	3.01- 3.50	50	
833.768	3.51- 4.00	50	
837.311	4.01- 4.50	50	
837.312	4.51- 5.00	50	
837.313	5.01- 5.50	50	
837.314	5.51- 6.00	50	
837.315	6.01- 6.50	50	
837.316	6.51- 7.00	50	
837.317	7.01- 7.50	50	
837.318	7.51- 8.00	50	
837.319	8.01- 8.50	50	
837.320	8.51- 9.00	50	
837.321	9.01- 9.50	50	
837.322	9.51- 10.00	50	



MedioTehna

Select setting rings

Setting rings, manufactured according DIN 2250 form C, 1 to 4 mm.

The size is indicated on the ring to three decimal places.

For all gauges also measuring reports can be ordered.

SELECT



Item No.	Size/mm	Price HRK
830.001	1	
830.002	1.2	
830.003	1.5	
830.004	1.8	
830.005	2	
830.006	2.2	
830.007	2.5	
830.008	2.8	
830.009	3	
830.010	4	

Setting rings

Manufactured according DIN 2250 form C. Available from 3 to 200 mm.

- DIN 2250 form C.
- Material: hardened steel.
- The size is indicated on the setting rings to three decimal places.
- With serial number.
- Delivery with a manufacturer measuring report.
- Individual setting rings from 3 - 32 mm: delivery in a plastic case, individual setting rings from 33 - 200 mm: delivery in a cardboard case.



MedioTehna

PRICE

Item No.	Size mm	Price HRK	Item No.	Size mm	Price HRK	Item No.	Size mm	Price HRK
911.070	3		911.099	33		911.131	88	
911.071	4		911.100	34		911.132	90	
911.072	5		911.101	35		911.133	92	
911.073	6		911.102	36		911.134	95	
911.074	7		911.103	37		911.135	98	
911.075	8		911.104	38		911.136	100	
911.076	9		911.105	40		911.137	105	
911.077	10		911.106	42		911.138	110	
911.079	11		911.107	44		911.139	115	
911.080	12		911.108	45		911.140	120	
911.081	13		911.109	46		911.141	125	
911.082	14		911.110	47		911.142	130	
911.083	15		911.114	48		911.143	135	
911.084	16		911.115	50		911.144	140	
911.085	17		911.116	52		911.145	145	
911.086	18		911.117	55		911.146	150	
911.087	19		911.118	58		911.147	155	
911.088	20		911.120	60		911.148	160	
911.089	21		911.121	62		911.149	165	
911.090	22		911.122	65		911.150	170	
911.091	23		911.123	68		911.151	175	
911.092	24		911.124	70		911.152	180	
911.093	25		911.125	72		911.153	185	
911.094	26		911.126	75		911.154	190	
911.095	27		911.127	78		911.155	195	
911.096	28		911.128	80		911.156	200	
911.097	30		911.129	82				
911.098	32		911.130	85				

LMW setting rings

Setting rings, manufactured according DIN 2250 form C, 1 to 315 mm.

- DIN 2250 form C.
- Material: hardened steel.
- The size is indicated on the setting rings to three decimal places to 100 mm. From 100 mm the nominal size is indicated in mm and separately the deviation in μm .
- Price on request up to 3 mm.

Also available:

- Higher accuracy,
- in tungsten carbide from 3 to 38 mm,
- form B rings for pneumatic measuring tools,
- intermediate and larger sizes,
- with coating,
- Go and NoGo limit ring gauges.



MedioTehna

Size mm	Price HRK	Size mm	Price HRK	Size mm	Price HRK	Size mm	Price HRK	Size mm	Price HRK
1		18		43		80		165	
1.2		19		44		82		170	
1.5		20		45		84		175	
1.8		21		46		85		180	
2		22		47		86		185	
2.2		23		48		88		190	
2.5		24		49		90		195	
2.8		25		50		92		200	
3		26		52		94		210	
3.5		27		54		95		220	
4		28		55		96		230	
4.5		29		56		98		240	
5		30		58		100		250	
6		31		60		105		260	
7		32		62		110		270	
8		33		64		115		280	
9		34		65		120		290	
10		35		66		125		300	
11		36		68		130		310	
12		37		70		135		315	
13		38		72		140			
14		39		74		145			
15		40		75		150			
16		41		76		155			
17		42		78		160			

Intermediate sizes over 3 mm are also available

Measuring reports

For all gauges also measuring reports can be ordered.

- ① Manufacturer measuring report (German) per gauge. Stating of product specifications, measured values after production, used traceable measuring devices, measuring inaccuracy and measuring date. A favourable choice when your quality system does not require traceable certificates.
- ② Traceable certificate (Dutch) with measuring reports of the ordered gauges. Besides stating of the measured values the extra assurance of an external inspection.

LMW taper gauges

To increase the already large capacity to transmit moments, some taper gauges are furnished with a lip which functions as catch lock.



Morse taper gauges

Indica- tion Morse	Without lip, DIN 229				With lip, DIN 230			
	Item No.	Price HRK	Item No.	Price HRK	Item No.	Price HRK	Item No.	Price HRK
	Plug:		Ring:		Plug:		Ring:	
0	832.531		832.532		832.552		832.553	
1	832.533		832.534		832.554		832.555	
2	832.535		832.536		832.556		832.557	
3	832.537		832.538		832.558		832.559	
4	832.539		832.540		832.560		832.561	
5	832.541		832.542		832.562		832.563	
6	832.543		832.544		832.564		832.565	

Metric taper gauges

Indica- tion metric	Without lip, DIN 234				With lip, DIN 235			
	Item No.	Price HRK	Item No.	Price HRK	Item No.	Price HRK	Item No.	Price HRK
	Plug:		Ring:		Plug:		Ring:	
4	804.001		804.011		–		–	
6	804.002		804.012		–		–	
80	804.003		804.013		804.021		804.031	
100	804.004		804.014		804.022		804.032	
120	804.005		804.015		804.023		804.033	

Short taper gauges

Indica- tion SK	Plug, DIN 2079		Ring, DIN 2080	
	Item No.	Price HRK	Item No.	Price HRK
30	832.568		832.569	
40	832.570		832.571	
50	832.572		832.573	
60	832.574		832.575	



LMW measuring mandrels

The cylinders are hollow and have four marks on the cylinder wall near the thread and numbered marks in successive distances of 90° on the face. The cylinder and the front face are ground and lapped. The hardness is (60 ± 2) HRc.

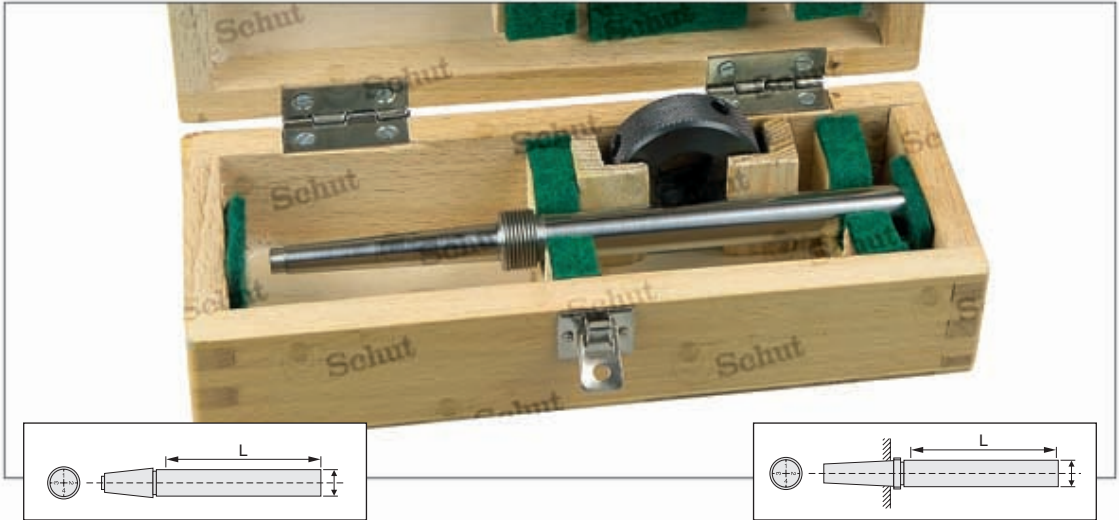

Measuring mandrels with internal thread, without external screw thread and nut

Item No.	Cone	Dimensions cylinder		Price
		ø/mm	length/mm	HRK
832.591	Sc 20	24	150	
832.592	Sc 30	32	200	
832.593	Sc 30	32	300	
832.594	Sc 40	40	300	
832.595	Sc 45	40	300	
832.596	Sc 50	40	300	
832.597	Sc 50	63	500	

Measuring mandrels without draw bar thread, with external screw thread and nut

Item No.	Cone	Dimensions cylinder		Price
		ø/mm	length/mm	HRK
832.581	Mc 0	12	75	
832.582	Mc 1	12	75	
832.583	Mc 2	24	150	
832.584	Mc 3	32	200	
832.585	Mc 4	40	300	
832.586	Mc 5	40	300	
832.587	Mc 6	63	500	
832.588	Mec 80	80	500	

Specifications of the accuracy:

straightness of the cylinder $\leq 3 \mu\text{m}$, out of roundness $\leq 3 \mu\text{m}$, eccentricity $\leq 3 \mu\text{m}$.

Other models are available.

LMW gauges for keyway depths on shafts

- Available in all common fits.
- Prices available on request.



MedioTehna

Thread gauges

The prices of the thread gauges apply to the following tolerances:

Kind of thread	Tolerances	
	Thread plug gauge	Thread ring gauge
Metric thread according ISO 1502 (DIN 13) up to and incl. M1.4 larger than M1.4	5H 6H	6h 6g (standard) 4h and 6e
Fixing pipe thread DIN EN ISO 228	center	A
Trapezoidal thread DIN 103	7H	7e

Other tolerances, sizes and kinds of threads are available on request; also available are special screw threads as per your design. Left-hand screw thread: price on request.



Measuring reports

For all gauges also measuring reports can be ordered.

- ① Manufacturer measuring report (German) per gauge. Stating of product specifications, measured values after production, used traceable measuring devices, measuring inaccuracy and measuring date. A favourable choice when your quality system does not require traceable certificates.
- ② Traceable certificate (Dutch) with measuring reports of the ordered gauges. Besides stating of the measured values the extra assurance of an external inspection.

LMW thread plug and ring gauges

Hardened steel thread plug gauges (up to M39: Go + NoGo, from M42: Go and NoGo separate) and thread ring gauges (Go or NoGo) for metric screw thread (ISO) with coarse pitch. Manufactured according ISO 1502 (DIN 13).

Indication M...	Price HRK Thread plug	Price HRK Thread ring	
1 x 0.25			
1.2 x 0.25			
1.4 x 0.3			
1.6 x 0.35			
1.8 x 0.35			
2 x 0.4			
2.2 x 0.45			
2.5 x 0.45			
3 x 0.5			
3.5 x 0.6			
4 x 0.7			
4.5 x 0.75			
5 x 0.8			
6 x 1			
8 x 1.25			
10 x 1.5			
12 x 1.75			
14 x 2			
16 x 2			
18 x 2.5			
20 x 2.5			
22 x 2.5			
24 x 3			
27 x 3			
30 x 3.5			
33 x 3.5			
36 x 4			
39 x 4			
Indication M...	Thread plug Go	Thread NoGo	Thread ring
42 x 4.5			
45 x 4.5			
48 x 5			
52 x 5			
56 x 5.5			
60 x 5.5			

Also most common sets available.

MedioTehna

LMW thread plug and ring gauges (continued)

Hardened steel thread plug gauges (Go + NoGo) and thread ring gauges (Go or NoGo) for metric screw thread (ISO) with pitch 0.5. Manufactured according ISO 1502 (DIN 13).

Indication M...x0.5	Price HRK Thread plug	Price HRK Thread ring
5		
6		
8		
10		
12		
14		
16		
18		
20		



MedioTehna

Hardened steel thread plug gauges (Go + NoGo) and thread ring gauges (Go or NoGo) for metric screw thread (ISO) with pitch 0.75. Manufactured according ISO 1502 (DIN 13).

Indication M...x0.75	Price HRK Thread plug	Price HRK Thread ring
6		
8		
10		
12		
14		
16		
18		
20		
22		
24		
26		
28		
30		

Hardened steel thread plug gauges (Go + NoGo) and thread ring gauges (Go or NoGo) for metric screw thread (ISO) with pitch 1. Manufactured according ISO 1502 (DIN 13).

Indication M...x1	Price HRK Thread plug	Price HRK Thread ring
8		
10		
11		
12		
14		
16		
18		
20		
22		
24		
25		
26		
27		
28		
30		



Hardened steel thread plug gauges (up to M40: Go + NoGo, from M42: Go and NoGo separate) and thread ring gauges (Go or NoGo) for metric screw thread (ISO) with pitch 1.5. Manufactured according ISO 1502 (DIN 13).

Indication M...x1.5	Price HRK Thread plug	Price HRK Thread ring
12		
14		
16		
18		
20		
22		
24		
25		
26		
27		
28		
30		

(continued on the next page)

LMW thread plug and ring gauges (continued)

Indication M... x 1.5	Price HRK Thread plug	Price HRK Thread ring	
<i>(continued)</i>			
32			
33			
34			
35			
36			
38			
39			
40			
Indication M... x 1.5	Thread plug		Thread ring
	Go	NoGo	
42			
45			
48			
50			

Hardened steel thread plug gauges (up to M40: Go + NoGo, from M42: Go and NoGo separate) and thread ring gauges (Go or NoGo) for metric screw thread (ISO) with pitch 2 (ISO 1502).

Indication M... x 2	Price HRK Thread plug	Price HRK Thread ring	
20			
22			
24			
26			
28			
30			
32			
34			
36			
38			
40			
Indication M... x 2	Thread plug		Thread ring
	Go	NoGo	
42			
45			
48			
50			



Hardened steel thread plug gauges (up to G1": Go + NoGo, from G1 1/8": Go and NoGo separate) and thread ring gauges (Go or NoGo) for non-sealing fixing pipe thread. Manufactured according DIN EN ISO 228.

Indication G..."	Price HRK Thread plug	Price HRK Thread ring	
1/8			
1/4			
3/8			
1/2			
5/8			
3/4			
7/8			
1			
Indication G..."	Thread plug		Thread ring
	Go	NoGo	
1 1/8			
1 1/4			
1 1/2			
1 3/4			
2			
2 1/4			
2 1/2			
2 3/4			
3			



Hardened steel thread plug and thread ring gauges for sealing pipe thread. Manufactured according DIN 2999.¹

Indication R..."	Price HRK Thread plug	Price HRK Thread ring
1/8		
1/4		
3/8		
1/2		
3/4		
1		
1 1/4		
1 1/2		
2		

Larger sizes available on request

¹ DIN 2999 is replaced with DIN EN 10226 (ISO 7).

LMW thread plug and ring gauges (continued)

Hardened steel thread plug gauges (up to 1¹/₄: Go + NoGo, from 1³/₈: Go and NoGo separate) and thread ring gauges (Go or NoGo) for American screw thread UNC and UNF manufactured according ANSI B1.2 class 2B (thread plug) and BS 919 2A (thread ring; manufactured according ANSI B1.2 class 2A available on request).

Indication UNC	Price HRK Thread plug	Price HRK Thread ring
No 1-64		
No 2-56		
No 3-48		
No 4-40		
No 5-40		
No 6-32		
No 8-32		
No 10-24		
No 12-24		
1/4 -20		
5/16 -18		
3/8 -16		
7/16 -14		
1/2 -13		
9/16 -12		
5/8 -11		
3/4 -10		
7/8 -9		
1 -8		
1 1/8 -7		
1 1/4 -7		

Indication UNC	Thread plug		Thread ring
	Go	NoGo	
1 3/8 -6			
1 1/2 -6			
1 3/4 -5			
2 -4 1/2			
2 1/4 -4 1/2			
2 1/2 -4			
2 3/4 -4			
3 -4			
3 1/4 -4			
3 1/2 -4			
3 3/4 -4			
4 -4			



Indication UNF	Price HRK Thread plug	Price HRK Thread ring
No 0-80		
No 1-72		
No 2-64		
No 3-56		
No 4-48		
No 5-44		
No 6-40		
No 8-36		
No 10-32		
No 12-28		
1/4 -28		
5/16 -24		
3/8 -24		
7/16 -20		
1/2 -20		
9/16 -18		
5/8 -18		
3/4 -16		
7/8 -14		
1 -12		
1 1/8 -12		
1 1/4 -12		

Indication UNF	Thread plug		Thread ring
	Go	NoGo	
1 3/8 -12			
1 1/2 -12			

Hardened steel tapered thread plug and thread ring gauges NPT for sealing pipe thread. Manufactured according ANSI/ASME B1.20.1.



Indication NPT..."	Price HRK Thread plug	Price HRK Thread ring
1/16		
1/8		
1/4		
3/8		
1/2		
3/4		
1		
1 1/4		
1 1/2		
2		
2 1/2		
3		

Thread plug and ring gauges in sets

Sets of thread plug gauges or thread ring gauges for inspection of metric ISO threads.



836.561



836.562



- For threads M3, M4, M5, M6, M8, M10 and M12.
- Tolerance class:
thread plug gauges: 6H,
thread ring gauges: 6g.
- Hardened steel, thread plug gauges with aluminum grip.
- Manufactured according ISO 1502 (DIN 13).
- Delivery in a wooden case with a manufacturer measuring report.



Item No.	Thread gauges set	Price HRK
836.561	Plug gauges (Go+NoGo)	
836.562	Ring gauges (Go)	
836.563	Ring gauges (NoGo)	

Plug gauges and setting rings in sets

- Hardened steel, plug gauges with aluminum grip.
- Set setting rings manufactured according DIN 2250 form C.
- Set plug gauges manufactured according DIN 2248/2249.
- Delivery in a wooden case with a manufacturer measuring report.



Item No.	Description	Price HRK
836.564	Setting rings: $\phi 4$, $\phi 5$, $\phi 6$, $\phi 8$ mm	
836.565	Setting rings: $\phi 10$, $\phi 12$, $\phi 16$, $\phi 20$, $\phi 25$ mm	
836.566	Plug gauges (Go+NoGo) H7: 3, 4, 5, 6, 8, 10, 12 mm	



Thread jaw gauges

Jaw-shaped gauge for inspection of external screw thread. Delivery excl. setting thread plug gauge.



MedioTehna

Available on request.

Adjustable snap gauges

Snap gauges with adjustable anvil. Especially suitable for Go/NoGo determination and batch measurements.

- Tungsten carbide measuring faces.
- Flatness of anvil: 1.5 μm .
- Parallelism between anvils: 0-32 mm: 3 μm /32-89 mm: 4 μm /89-152 mm: 5 μm .
- To set for example with gauge blocks.
- Conforms to factory standard.
- Delivery with a manufacturer measuring report.

MedioTehna

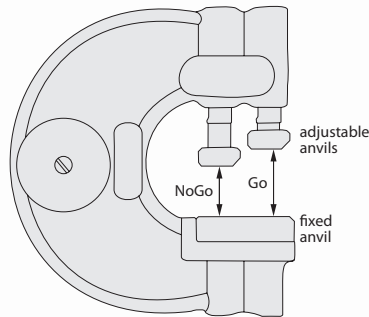

860.016

Item No.	Measuring range/mm	Price HRK
860.012	0- 6	
860.013	6- 13	
860.014	13- 19	
860.015	19- 25	
860.016	25- 32	
860.017	32- 38	
860.018	38- 44	
860.019	44- 51	
860.020	51- 57	
860.021	57- 63	
860.022	63- 70	
860.023	70- 76	
860.024	76- 82	
860.025	82- 89	
860.026	89- 95	
860.027	95-101	
860.028	101-108	
860.029	108-114	
860.030	114-120	
860.031	120-127	
860.032	127-133	
860.033	133-139	
860.034	139-146	
860.035	146-152	

Drill gauges

Gauge in the form of a steel plate with bores of increasing diameters for determining drill diameters.

- Increment: 0.1 mm.



836.640

Item No.	Measuring range/mm	Number of bores	Price HRK
836.640	0.1 - 10	100	

Measuring wedges

Measuring wedges for quick measurements and checks of slits, key-ways, distances, etc.

- Measuring range: 0.4 - 26 mm.
- Graduation: 0.05, 0.1 or 0.2 mm.
- Laser engraving.



909.537



909.535



909.536



856.331



Item No.	Measuring range/mm	Graduation mm	Price HRK
909.535	0.4 - 6	0.05	
856.331	0.5 - 11	0.1	
909.536	1 - 15	0.1	
909.537	2 - 26	0.2	

Twist drill grinding gauges

For checking twist drills at their top and on the right value of 120° angle of the twist drill point. The maximum drill diameter is 50 mm.



910.372

NEW

Universal twist drill grinding gauge, also called *Y-gauge*. Besides the standard angle of 120°, this gauge also has a 90° angle for countersink drills, and some special angles for center drills.

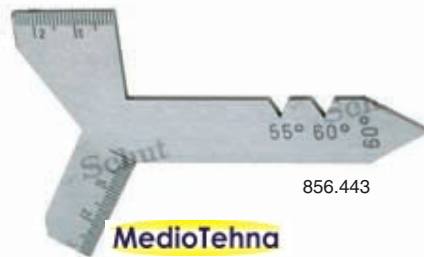

856.443

Item No.	Description	Price HRK
910.372	Twist drill grinding gauge	
856.443	<i>Y-gauge</i>	

Flat plug gauges

- Measuring range: 1 - 60 mm.
- Graduation: 0.1 mm.
- Stainless steel, matt chrome-plated finish.
- Graduation on both sides.
- Ground measuring faces.
- Laser engraving.



907.876

Item No.	Measuring range/mm	Price HRK
907.876	1 - 15	
909.516	15 - 30	
909.517	30 - 45	
909.534	45 - 60	



Conical plug gauges

- Measuring range: \varnothing 1 - 45 mm.
- Graduation: 0.1 mm.
- Hardened, ground and chrome finished.
- With anodized handle.



909.490

Item No.	Measuring range/mm	Price HRK
909.490	\varnothing 1 - 6	
909.491	\varnothing 4 - 15	
909.492	\varnothing 15 - 30	
909.493	\varnothing 30 - 45	

MedioTehna



Nozzle gauges

Set of pins in holder serving as a gauge to determine jet nozzle sizes.



856.107

Item No.	Number of pins	Sizes mm	Price HRK
856.107	20	\varnothing 0.45 - 1.50	
856.108	16	\varnothing 1.50 - 3.00	
856.124	16	\varnothing 3.00 - 4.50	
856.125	16	\varnothing 4.50 - 6.00	

Nozzle gauges with vernier

Nozzle gauges with a hardened and ground tapered needle.

- Measuring range: \varnothing 0 - 5 mm.
- Vernier: 0.01 mm.



Item No.	Measuring range/mm	Price HRK
856.110	\varnothing 0 - 5	

Center gauges

For checking thread cutting tools for Whitworth thread 55° or metric thread 60°.

MedioTehna



856.444



856.445

Item No.	Description	Price HRK
856.444	Whitworth 55°	
856.445	Metric 60°	

Thread cutting tool gauges



856.446



856.447



856.449



856.451

Item No.	Description	Price HRK
856.446	Universal thread cutting tool gauge for angular thread and flat thread	
856.447	Trapezoidal thread cutting tool gauge for trapezoidal thread DIN 103 (30°, 2-12 mm)	
856.449	Combined lathe and thread cutting tool gauge for – cutting tool wedge angle, – trapezoidal thread DIN 103 (30°, 2-12 mm), and – angular thread (40° - 80°)	
856.451	Thread cutting tool gauge for – rectangular thread, – trapezoidal thread DIN 103 (30°, 2-12 mm), and – angular thread (55° and 60°)	

Angle gauge set

- Measuring range: 5 - 90° (supplementary angles: 90 - 175°).
- Increment: 5° (18 pieces).
- Multiple angles per angle gauge:
 - primary angles (1, 2*, 3, 4),
 - supplementary angles (5, 6), and
 - ½ primary angles (7, 8).
- Delivery in a soft case.

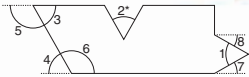

* Angle 2: only with the angle gauges from 20°.



Item No.	Description	Price HRK
909.410	Angle gauge set	

Angle gauges

- Measuring range: 1 - 45°.
- Number of blades: 20.
- Angles: 1° - 2° - 3° - 4° - 5° - 6° - 7° - 8° - 9° - 10° - 12° - 14° - 16° - 18° - 20° - 25° - 30° - 35° - 40° - 45°.



Item No.	Description	Price HRK
908.798	Angle gauges	

Radius gauges

- Measuring range radius: 1 - 25 mm.
- Increment:
 - 1 - 3 mm: 0.25 mm,
 - 3.5 - 20 mm: 0.5 mm,
 - > 20 mm: 1.0 mm.
- Includes blades for both inside and outside radii.

MedioTehna



Item No.	Radius range/mm	Number of blades	Price HRK
907.766	1 - 7	17+17	
907.767	7.5 - 15	16+16	
907.768	15.5 - 25	15+15	

Shape and radius gauge

This stainless steel gauge can be used to adopt various complex shapes of tools and workpieces. When the gauge is pressed against the part which has to be checked, it takes on the shape of this part. Because of the graduation (mm) on the case, the shape can be checked easily.

Because the tracers were supported under pressure, they don't move on their own.



Item No.	Measuring range/mm	Price HRK
836.319	150 x 40	

Set of welding seam gauges

- For weld thickness: 3 - 12 mm.
- Up to 7 mm increasing with 0.5 mm, plus 8, 10 and 12 mm.
- Total: 12 pieces.
- Bright steel.



Item No.	Description	Price HRK
856.452	Welding seam gauges	

Welding seam gauge

For measurement of welding seams.

- Graduation: 0.2 mm.
- Stainless steel.
- Delivery in a soft case.



Item No.	Description	Price HRK
856.438	Welding seam gauge	

Welding seam calipers

For measurement of welding seams.

- Measuring range: 0 - 20 mm.
- Analog: vernier 0.1 mm, digital: resolution 0.01 mm.
- Delivery in a soft case (836.423) or a plastic case (906.429).

Analog

- Stainless construction.

Digital

- mm/inch conversion.
- On/off switch.
- Reset.
- Power supply: 1 battery type V357.

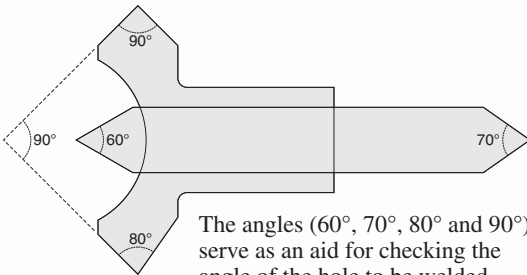
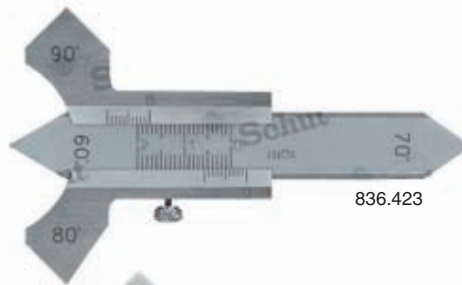

MedioTehna

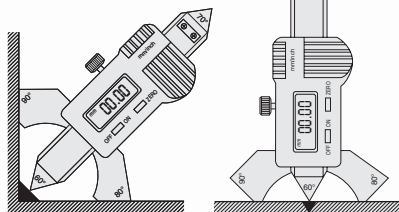

Item No.	Measuring range/mm	Price HRK
Analog: 836.423	0 - 20	
Digital: 906.429	0 - 20	
Option: 836.535	Spare battery type V357	

Digital measuring wedge

Digital measuring wedge for measurements and checks of slits, key-ways, distances, etc.

- Measuring range: 0.2 - 30 mm.
- Resolution: 0.01 mm.
- mm/inch conversion.
- On/off switch.
- Reset.
- Large LCD display.
- Locking screw.
- Power supply: 1 battery type V357.



Item No.	Measuring range/mm	Accuracy mm	Price HRK
910.283	0.2 - 30	±0.02	
Option: 836.535 Spare battery type V357			

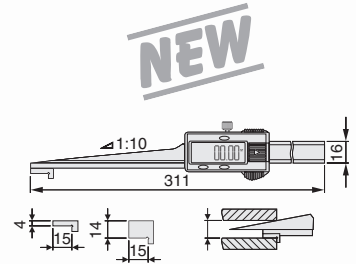

Chamfer calipers

- Measuring range: 0 - 8 mm.
- Resolution: 0.01 mm.
- Accuracy: ±0.03 mm.
- mm/inch conversion.
- On/off switch.
- Reset.
- Locking screw.
- Delivery in a case.
- Power supply: 1 battery type V357.



Item No.	Angle	Price HRK
910.265	30°	
910.266	45°	
910.267	60°	
Option: 836.535 Spare battery type V357		

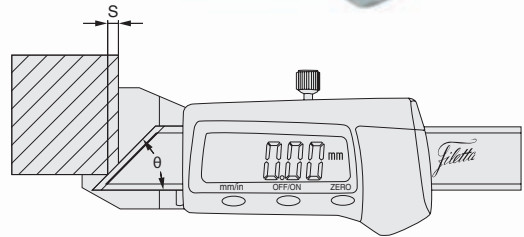

Universal meter for bevels

Universal instrument for measurement of bevels from 0.5 to 10 mm. Direct reading of the measured bevel (30°, 45°, 60°).

- Measuring range: 30°: 15 mm,
45°: 10 mm,
60°: 5 mm.
- Hardened stainless steel construction.
- Delivery in a wooden case.



Item No.	Description	Price HRK
838.727	Universal meter for bevels	

MedioTehna

Thread and tolerance tables

Thread table

Table with all standard international thread indications: metric, BSW, Gas, BSF, Pg, BA, UNC, UNF, UNEF, EG-M and EG-MF.

Tolerance table

Table comprising all tolerances and fits according ISO 286-2, up to 500 mm (table with over 6400 pairs of tolerance values for internal and external measurements).

Conversion table mm/inch

For converting from mm to inch and from inch to mm.



835.162

835.163

835.164

MedioTehna

Item No.	Description	Price HRK
835.162	Thread table	
835.163	Tolerance table	
835.164	Conversion table mm/inch	

Flat thickness gauge

Gauge to measure, among others, the thickness of steel plating.

- Measuring range: 1 - 13 mm.
- Graduation: 0.5 mm.
- Stainless steel.



Item No.	Measuring range/mm	Price HRK
907.899	1 - 13	

Screw pitch gauges

Item No.	Type of thread	Number of blades	Price HRK
856.456	Metric	24	
856.457	Whitworth	28	
856.458	BSP	6	
856.459	Metric/Whitworth	52	
856.460	Metric/Whitworth/BSP	58	
856.461	UNC/UNF	30	



Thread	Angle	Number of Blades	blades
Metric	60°	24	Pitch/mm: 0.25/0.3/0.35/0.4/0.45/0.5/0.6/0.7/0.75/0.8/0.9/1.0/1.25/1.5/1.75/2.0/2.5/3.0/3.5/4.0/4.5/5.0/5.5/6.0
Whitworth	55°	28	Threads per inch: 62/60/48/40/36/32/30/28/26/25/24/22/20/19/18/16/14/13/12/11/10/9/8/7/6/5/4.5/4
BSP	55°	6	Threads per inch: 28/19/14/11/10/8
UNC/UNF	60°	30	Threads per inch: 42/40/38/36/34/32/30/28/27/26/24/22/20/18/16/15/14/13/12/11.5/11/10/9/8/7/6/5.5/5/4.5/4

Magnifiers / Microscopes / Glass rulers / Stereo microscopes Endoscopes



Peak stand magnifier 5x

Standard, all-purpose magnifier.

- Dimensions:
ø 35 x 55 mm.



Item No.	Price HRK
905.110	

Peak stand magnifier 10x

Standard, all-purpose magnifier. Very suitable for inspection of tissues, structures and photographic negatives.

- Dimensions:
ø 34 x 41 mm.



Item No.	Price HRK
905.112	

Peak stand magnifier 10x

A simple, all-purpose magnifier.

- Dimensions:
ø 41 / ø 45 x 40 mm.

MedioTehna



Item No.	Price HRK
905.316	

Peak stand magnifier 15x

Bright images with high contrast due to a coated achromatic lens. With wide acrylic tube.

- Dimensions:
ø 27 / ø 36 x 33 mm.



Item No.	Price HRK
905.114	

Peak stand magnifier 22x

Bright images with high contrast due to a coated achromatic lens. Suitable for inspection of high precision work.

- Dimensions:
ø 28 x 30 mm.



Item No.	Price HRK
905.116	

Peak magnetic magnifier 5x

This magnifier has two small magnets which make sure that the magnifier can be put on a fixed position without moving. By placing this magnifier on hard to read scale divisions of, for example, graduated rulers, height gauges or micrometers, the possibility of reading errors substantially reduces.

- Field of view: $\varnothing 30$ mm.
- Dimensions: $\varnothing 44 \times 20 \times 30$ mm.
- Weight: 15 g.



Item No.	Description	Price HRK
905.210	Magnetic magnifier 5x	

Peak eye magnifiers 3.3x...20x

Eye magnifiers can be placed in front of the eye easily, which makes them ideal tools for working on small products like watches, clocks and jewelry.

- Made of aluminum.
- Weight: 10- 16 g.
- A small hole in the tube prevents the lens from becoming fogged up.



MedioTehna

Item No.	Type	Magnification	Lenses	Price HRK
905.390	A13D	3.3x	1	
905.391	A16D	4.0x	1	
905.392	A20D	5.0x	1	
905.393	A26D	6.7x	1	
905.394	A40D	10.0x	2	
905.299	A48D	12.0x	1	
905.300	A60D	15.0x	1	
905.301	A80D	20.0x	1	

Peak scale magnifier 3x

Scale magnifier with a lens system separated from the scale by a stand, hereby creating a larger working distance, field of view and luminous intensity. The scale is placed in a rotatable ring in the base of the stand.

- Field of view: $\varnothing 58$ mm.
- Measuring range scale: 54 mm.
- Graduation: 0.1 mm.
- Dimensions: 76 x 105 x 96 mm.
- Weight: 378 g.



Item No.	Description	Price HRK
905.328	Magnifier with scale and stand	

Peak zoom magnifiers 8-16x and 10-20x

Unique stepless zoom lens with sufficient brightness in each stage of magnification and a minimum of optical aberration. With click-stop on magnifications 8/10/12/14/16x and 10/15/20x, respectively. Equipped with scale.

- Field of view: \varnothing 20 - 10 mm or \varnothing 13 - 7 mm.
- Graduation: 0.1 mm.
- For optional scales: see "Peak scales \varnothing 35 mm".



Item No.	Magnification	Field of view \varnothing /mm	Adjustment range eye correction	Measuring range/mm	Dimensions mm	Price HRK
905.197	8 - 16x	20 - 10	+2.5D to -5D	16	\varnothing 45 x 65	
905.198	10 - 20x	13 - 7	+5D to -3.5D	12	\varnothing 42 x 52	

Options:
 904.028 Illumination
 495.153 Battery type C (2 needed)

Peak telecentric magnifier 7x

A telecentric magnifier shows objects, which are at different distances, with the same magnification. In this way 3D objects, or e.g. a needle above a scale, can be shown and measured accurately without parallax error.

- Field of view: \varnothing 24 mm.
- Measuring range scale: 20 mm.
- Graduation: 0.1 mm.
- Adjustable diaphragm with apertures \varnothing 0.5, 1 and 3 mm.
- Dimensions: \varnothing 38 x 74 mm.
- For optional scales: see "Peak scales \varnothing 26 mm".



Item No.	Description	Price HRK
905.136	Telecentric magnifier 7x including case and standard scale (for scales of \varnothing 26 mm)	

Peak stand magnifier 4x

This practical and convenient magnifier can be used for many purposes, like inspecting films. The magnifier is delivered with a clear and a black base, which allows you, depending on the amount of light, to choose the base which is most suitable for your application.

- Field of view: \varnothing 45 mm.
- Dimensions: 51 x 51 x 65 mm.
- Weight: 80 g.



Item No.	Description	Price HRK
905.399	Stand magnifier 4x	

Peak stand magnifier 8x

Convenient and smartly designed magnifier with achromatic lens. A scale is engraved at the bottom of the transparent acrylic base. Photographic negatives can be inspected using the base with opal glass.

- Field of view: 24 x 36 mm.
- Dimensions without base: 46 x 49 x 39 mm.
- Weight: 52 g.



Item No.	Description	Price HRK
905.290	Magnifier w/o base	
Option:		
905.291	Base	

Peak light magnifier 3.5x

Large square lens (52 x 52 mm) of plastic with illumination, e.g. for reading maps and indicators, and for inspection of production processes.

- Dimensions: 60 x 75 x 190 mm.
- Weight (without batteries): 120 g.
- Power supply: 2 batteries type C.



Item No.	Description	Price HRK
905.212	Magnifier (w/o batteries)	
Option:		
495.153	Battery type C (2 needed)	

Peak monocular telescopes

Lightweight pocket-size telescopes with erect image.

- Dimensions 905.207: \varnothing 22.5 x 50 mm,
905.208: \varnothing 22.5 x 53 mm.
- Weight: 32 g.
- Delivery in a soft case.

MedioTehna



905.207

Item No.	Magnification	Lens aperture \varnothing /mm	Close focus distance/mm	Field of view (angle)	Field of view* \varnothing /mm	Field of view* \varnothing /m	Price HRK
905.207	2x	8	100	11°	12	192	
905.208	4x	10	220	10°	29	175	

* Field of view respectively at close focus distance and at 1000 m.

Peak head magnifiers 2.2x ... 5.2x

Because of the velcro strip, the head magnifier can be used easily. The great advantage of a head magnifier is that the user has both hands free for e.g. production and assembly of precision instruments. The head magnifier is designed in such a way that people who wear glasses can use it as well. With the extra pair of lenses inside the head magnifier, the magnification can be enhanced from 2.2x to 3.3x.

- Clear, broad and 3-dimensional view.
- Weight 905.318: 100 g,
905.317: 118 g.

905.318

905.317



Item No.	Magnification	Price HRK
905.318	2.2x / 3.3x	
905.317	2.2x / 3.3x / 4.1x / 5.2x	

Peak pen microscopes with EIM 25x ... 100x

These pen microscopes have a fixed scale and EIM system. With standard microscopes, the magnification is upside down, but because of the EIM system, this is not the case with these pen microscopes.

- Dimensions: $\varnothing 20.7 \times 111$ mm.
- Weight: 25 - 28 g.



905.404

MedioTehna

Item No.	Magnification	Field of view \varnothing /mm	Measuring range/mm	Graduation mm	Price HRK
905.404	25x	3.50	3.0	0.05	
905.405	50x	1.70	1.6	0.02	
905.406	75x	1.10	1.0	0.01	
905.407	100x	0.86	0.8	0.005	

Peak pen microscopes 25x ... 100x

- Dimensions: $\varnothing 12.4 \times 127$ mm.
- Weight: 13 - 16 g.
- With a fixed scale (only 905.263/264).



905.267

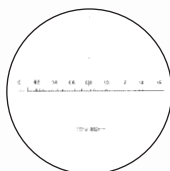

Item No.	Magnification	Field of view \varnothing /mm	Measuring range/mm	Graduation mm	Price HRK
905.267	25x	3.30	—	—	
905.268	50x	2.00	—	—	
905.269	75x	1.09	—	—	
905.266	100x	0.84	—	—	
With fixed scale:					
905.263	25x	3.30	3.00	0.05	
905.264	50x	2.00	1.60	0.02	

Peak light magnifiers 10x and 15x

Magnifier with illumination.

- Field of view: $\varnothing 25$ mm.
- Dimensions and weight (without batteries):
905.118: 175 x 35 x 41 mm, 81 g,
905.119: 180 x 36 x 42 mm, 90 g.
- Power supply: 2 batteries type C, not included.



905.118

Peak folding magnifiers 7x ... 20x

Steinheil magnifiers with an excellent chromatic correction and a large field of view.

- Dimensions: 39 x 24 x 22 mm.
- Weight: 18 - 22 g.



905.202

MedioTehna

Item No.	Magnification	Price HRK
905.118	10x	
905.119	15x	
Option:		
495.153	Battery type C (2 needed)	

Item No.	Magnification	Field of view \varnothing /mm	Price HRK
905.200	7x	16	
905.202	10x	15.5	
905.204	14x	12	
905.206	20x	7	

Peak folding magnifiers 3x ... 9x

Because of their small size, these folding magnifiers are easy to use. Available in several magnifications, with one or two lenses. The advantage of two lenses is that it gives a very sharp image, because the image error of the first lens is being corrected by the second one.

A mm scale is engraved at each of the four sides of the base. The scale length is equal to the width of the field of view (see table).



905.230



905.379

Item No.	Magnification	Field of view/mm	Number of lenses	Material/color	Price HRK
905.230	9x	10 x 10	1	Al/clear	
905.375	7x	15 x 15	1	Al/clear	
905.376	6x	25 x 25	1	Al/clear	
905.377	9x	10 x 10	1	Al/black	
905.378	7x	15 x 15	1	Al/black	
905.379	6x	25 x 25	1	Al/black	
905.383	4x	30 x 30	2	Al/black	
905.384	3x	50 x 50	2	Al/black	
905.380	9x	10 x 10	2	Zn/black	
905.381	8x	15 x 15	2	Zn/black	
905.382	6x	25 x 25	2	Zn/black	

Peak scale magnifier 7x

All-purpose scale magnifier. Aberrations are avoided by the excellent achromatic lenses.

- Field of view: \varnothing 26 mm.
- Measuring range standard scale: 20 mm.
- Graduation: 0.1 mm.
- Dimensions: \varnothing 36 x 62 mm.
- Weight: 56 g.



Scale magnifier with illumination 905.138

- Field of view: \varnothing 22 mm.
- Dimensions: \varnothing 36 x 58 x 175 mm.
- Weight (without batteries): 118 g.
- Power supply: 2 batteries type C.

Item No.	Description	Price HRK
905.140	Magnifier with standard scale in a soft case	
905.155	Set of magnifier 7x and five scales in a plastic case	
905.138	Magnifier 905.140 with illumination (without batteries)	
Option:		
495.153	Battery type C (2 needed)	



Set 905.155

Scale magnifier 7x in a set with the five most frequently used scales (2, 3, 7, 8 and 10).

Peak scales \varnothing 26 mm

Aside from the standard scale, various other scales are available, each one with its own specific application. These scales are interchangeable in scale magnifiers like the one above.

Item No.	Scale	Price HRK
905.141	no. 1	
905.142	no. 2	
905.143	no. 3	
905.144	no. 4	
905.145	no. 5	
905.146	no. 6	
905.147	no. 7	
905.148	no. 8	
905.149	no. 9	
905.150	no. 10	
905.151	no. 11	
905.152	no. 12	
905.153	standard	

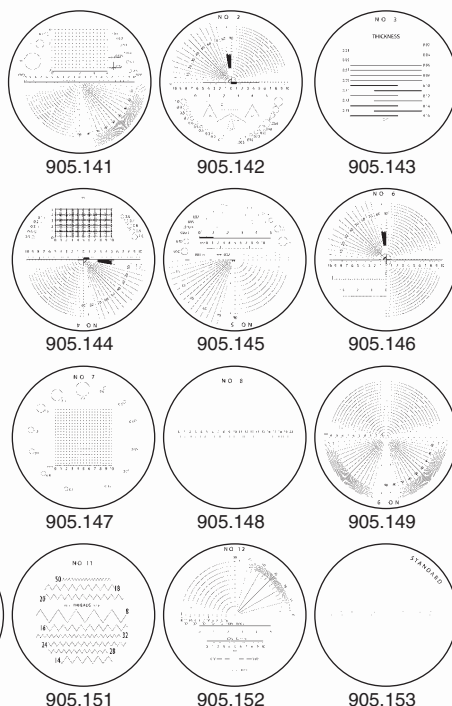

Peak scale magnifier 10x

All-purpose scale magnifier. Aberrations are avoided by the excellent achromatic lenses. High resolution and large field of view.

- Field of view: \varnothing 35 mm.
- Measuring range standard scale: 30 mm.
- Graduation: 0.1 mm.
- Dimensions: \varnothing 46 x 44 mm.
- Weight: 74 g.



MedioTehna

Scale magnifier with illumination 905.178

- Field of view: \varnothing 32 mm.
- Dimensions: \varnothing 47 x 45 x 185 mm.
- Weight (without batteries): 134 g.
- Power supply: 2 batteries type C.

Set 905.195

Scale magnifier 10x in a set with the five most frequently used scales (2, 3, 7, 8 and 10).



Item No.	Description	Price HRK
905.180	Magnifier with standard scale in a soft case	
905.195	Set of magnifier 10x and five scales in a plastic case	
905.178	Magnifier 905.180 with illumination (without batteries)	
Option:		
495.153	Battery type C (2 needed)	

Peak scales \varnothing 35 mm

Aside from the standard scale, various other scales are available, each one with its own specific application. These scales are interchangeable in scale magnifiers like the one above.

Item No.	Scale	Price HRK
905.181	standard	
905.182	no. 1	
905.183	no. 2	
905.184	no. 3	
905.185	no. 4	
905.186	no. 5	
905.187	no. 6	
905.188	no. 7	
905.189	no. 8	
905.190	no. 9	
905.191	no. 10	
905.192	no. 11	
905.193	no. 12	

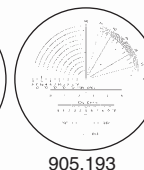
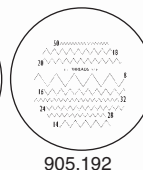
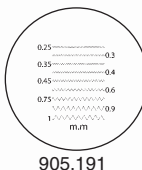
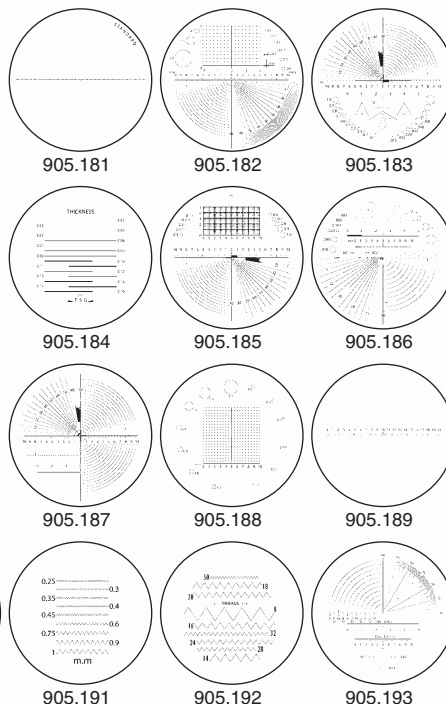

Peak scale magnifier 30x

- Field of view: $\varnothing 7$ mm.
- Measuring range standard scale: 5 mm.
- Graduation: 0.05 mm.
- Dimensions: $\varnothing 30 \times 19$ mm.
- Weight: 16 g.



Scale magnifier with LED illumination 905.287

- Dimensions: $\varnothing 43 \times 65 \times 184$ mm.
- Weight (without batteries): 48 g.
- Power supply: 2 batteries type AAA.



Item No.	Description	Price HRK
905.285	Scale magnifier in a soft case	
905.287	Magnifier 905.285 with illumination (without batteries)	
Options:		
497.914	Battery type AAA (2 needed)	
905.286	Separate standard scale	
905.179	LED penlight	

Peak anastigmatic scale magnifiers 4x and 7x

Magnifier with anastigmatic lens. This is a combined objective which reflects a large, undistorted image with sharp features, very suitable for inspection of (photographic) films.

- Large field of view, 905.216: $\varnothing 58$ mm,
905.400: $\varnothing 41$ mm.
- Removable scale with mm graduation.
- Measuring range scale 905.217: 54 mm,
905.401: 36 mm.
- Graduation scale: 0.1 mm.
- Dimensions and weight:
905.216: $\varnothing 73 \times 77$ mm, 272 g,
905.400: $\varnothing 55 \times 53$ mm, 103 g.

MedioTehna



905.216

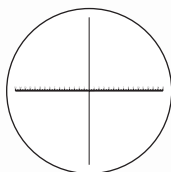

905.400

Item No.	Description	Price HRK
905.216	Scale magnifier 4x	
905.400	Scale magnifier 7x	
Options:		
905.217	Standard scale for magnifier 905.216	
905.401	Standard scale for magnifier 905.400	

Peak scale magnifier 15x

- Field of view: $\varnothing 20$ mm.
- Measuring range standard scale: 14 mm.
- Graduation: 0.1 mm.
- Dimensions: $\varnothing 35 \times 33$ mm.
- Weight: 40 g.



Scale magnifier with LED illumination 905.278

- Dimensions: $\varnothing 43 \times 65 \times 184$ mm.
- Weight (without batteries): 72 g.
- Power supply: 2 batteries type AAA.



Item No.	Description	Price HRK
905.270	Scale magnifier in a soft case	
905.278	Magnifier 905.270 with illumination (without batteries)	
Options:		
497.914	Battery type AAA (2 needed)	
905.272	Separate standard scale	
905.273	Scale no. 1	
905.274	Scale no. 2	
905.275	Scale no. 8	
905.179	LED penlight	

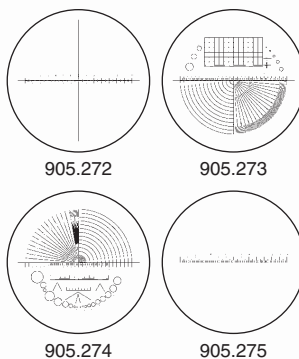

Peak ABC magnifier 3-18x

The ABC magnifier consists of three lenses. Combining the three lenses, seven different magnifications are possible.

- Magnification: 3x, 6x, 9x, 12x, 14x, 16x and 18x.
- Magnification and diameter of the lenses:
 - lens A: 12x, \varnothing 14 mm,
 - lens B: 3x, \varnothing 28 mm,
 - lens C: 6x, \varnothing 20 mm.
- Dimensions: 60 x 39 x 24 mm.
- Weight: 76 g.



Item No.	Description	Price HRK
905.196	ABC magnifier 3-18x	

Peak magnifying glass 2.5-5x

This model of the classic magnifying glass has a lens-in-lens construction. In the big \varnothing 75 mm lens a smaller \varnothing 20 mm lens has been integrated which offers extra strong magnification. The big lens has a 2.5x magnification, the small lens 5x.

- Dimensions: \varnothing 80 x 170 mm.
- Weight: 111 g.



Item No.	Description	Price HRK
905.214	Magnifying glass 2.5 - 5x	

Magnifier on magnetic stand

- Magnification: 2x (\varnothing 90 mm).
- Total length: 280 mm.
- Magnetic force: 600 N.



Item No.	Description	Price HRK
909.609	Magnifier on magnetic stand	

Peak flexible stand magnifier

This magnifier has a flexible arm which can be adjusted freely from a solid and stabilized stand. The lens can be put in many positions for the most ergonomic use thus leaving both hands of the user free.

- Dimensions: 145 x 120 x 485 mm (maximum height).
- Weight: 1.5 kg.



905.279

Item No.	Magnification	Lens \varnothing /mm	Price HRK
905.279	1.7x	115	
905.428	2.2x	90	

Stand microscopes 20x ... 100x

These stand microscopes are available in four versions. All four are compact and lightweight, but are especially characterized by their large field of view. Delivered in a case, including LED penlight, matching standard scale and objective. The microscopes come with a Huygens eyepiece (magnification 10x) and with a detachable soft rubber eye adapter. All-purpose use with high precision.

A scale graduation (with a 10 mm scale range) has been engraved on the focusing ring which allows height measurements at a resolution of 0.1 mm.

- Focusing with helicoil ring.
- Eyepiece: 10x.
- Dimensions: $\varnothing 41.5 \times 122$ mm.
- Weight (without batteries): 262 - 264 g.
- Power supply: 1 battery type AAA.

MedioTehna



Item No.	Magnification microscope	Price HRK
Standard scales:		
910.414	20x	
910.415	40x	
910.416	60x	
910.417	100x	
910.422	Individual eyepiece 10x	
Objectives:		
910.418	Individual objective 2x	
910.419	Individual objective 4x	
910.420	Individual objective 6x	
910.421	Individual objective 10x	



910.411

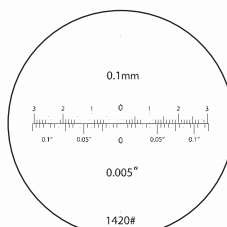

910.414



910.422

910.418



Item No.	Magnification	Objective	Field of view \varnothing /mm	Working distance/mm	Measuring range/mm	Graduation mm	Price HRK
910.409	20x	2x	7.2	20	6	0.1	
910.410	40x	4x	3.6	21	3	0.05	
910.411	60x	6x	2.4	13.5	2	0.02	
910.412	100x	10x	1.45	7	1	0.01	
Options:							
497.914	Spare battery type AAA						
910.413	LED penlight						

Peak stand microscopes 20x ... 200x

These stand microscopes are available in five versions. All five are compact and lightweight, but are especially characterized by their large field of view. Delivery in a case, including LED illumination, matching standard scale and objective. The microscopes come with a Huygens eyepiece (magnification 10x) and with a detachable soft rubber eye adapter. All-purpose use with high precision.

Type 2034

A scale graduation (with a 10 mm scale range) has been engraved on the focusing ring which allows height measurements at a resolution of 0.1 mm.

- Focusing with helicoid ring.
- Dimensions: $\varnothing 63 \times 172$ mm.
- Weight (without batteries): 237-241 g.
- Power supply: 2 batteries type AAA.

MedioTehna



Type 2034

Item No.	Magnification	Field of view \varnothing /mm	Working distance/mm	Measuring range/mm	Graduation mm	Price HRK
905.320	20x	7.2	36	6	0.1	
905.330	40x	3.6	18.7	3	0.05	
905.340	60x	2.4	10.8	2	0.02	
905.350	100x	1.45	5.7	1.2	0.01	
905.355	150x	0.96	9.2	0.9	0.005	
905.370	200x	0.72	6.7	0.6	0.002	
Options:						
497.914	Spare battery type AAA (2 needed)					
905.179	LED penlight					

Peak individual scales

The in the eyepiece integrated scale can be changed, for example when the magnification of the microscope changes (see "Individual objectives"). Additionally, an extra eyepiece (without scale and soft rubber eye adapter) is available, so the eyepiece doesn't need to be disassembled each time the scale is being changed.

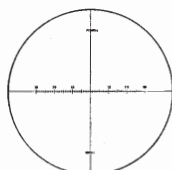

905.321

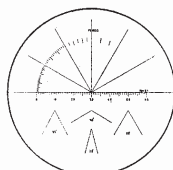

905.325

Item No.	Magnification microscope	Scale	Price HRK
Standard scales:			
905.321	20x	no. 54	
905.331	40x	no. 64	
905.341	60x	no. 74	
905.351	100x	no. 84	
905.356	150x	no. 94	
905.337	200x	no. 104	
905.388	300x	no. 114	
For inspection of printed matter and tools:			
905.325	20x	no. 55	
905.335	40x	no. 65	
904.042	Individual eyepiece 10x		

Peak stand microscopes 20x ... 300x (continued)

Type 2054

This type primarily differs from the type 2034 in the focusing mechanism and the sturdy die-cast aluminum base.

- Focusing with rack-and-pinion.
- Dimensions: $\varnothing 63 \times 172$ mm.
- Weight (without batteries): 263 - 267 g.
- Power supply: 2 batteries type AAA.

MedioTehna



Type 2054

Peak individual objectives

The objectives are also separately available. This gives you the great advantage that you can get all magnifications with one scale microscope. The magnification of the eyepiece is 10x.

Item No.	Magnification objective	Magnification microscope	Price HRK
905.332	4x	40x	
905.342	6x	60x	
905.352	10x	100x	
905.357	15x	150x	
905.372	20x	200x	
905.387	30x	300x	

Item No.	Magnification	Price HRK
Type 2054:		
905.411	40x	
905.412	60x	
905.413	100x	
905.414	150x	
905.416	300x	
Options:		
497.914	Spare battery type AAA (2 needed)	
905.179	LED penlight	

For other specifications: see table of type 2034.

Stand microscopes 20x ... 100x with LED illumination

These stand microscopes are available in four versions. All four are compact and lightweight, but are especially characterized by their large field of view. Delivered in a case, including LED ring light, matching standard scale and objective. The microscopes come with a Huygens eyepiece (magnification 10x) and with a detachable soft rubber eye adapter. All-purpose use with high precision.

A scale graduation (with a 10 mm scale range) has been engraved on the focusing ring which allows height measurements at a resolution of 0.1 mm.

- Focusing with helicoid ring.
- Eyepiece: 10x.
- Illumination: 3 LEDs.
- Dimensions: $\varnothing 41.5 \times 122$ mm.
- Weight (without batteries): 285 g.
- Power supply: 4 batteries type V394.



910.404



910.422



910.404

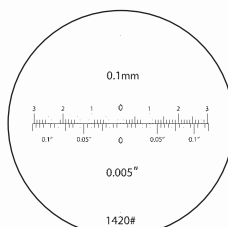

910.414



910.418

MedioTehna

Item No.	Magnification microscope	Price HRK
Standard scales:		
910.414	20x	
910.415	40x	
910.416	60x	
910.417	100x	
910.422	Individual eyepiece 10x	
Objectives:		
910.418	Individual objective 2x	
910.419	Individual objective 4x	
910.420	Individual objective 6x	
910.421	Individual objective 10x	

Item No.	Magnification	Objective	Field of view \varnothing /mm	Working distance/mm	Measuring range/mm	Graduation mm	Price HRK
910.404	20x	2x	3.3	17	0	0.1	
910.405	40x	4x	2.0	11.7	1.6	0.05	
910.406	60x	6x	1.1	11.7	1.0	0.02	
910.407	100x	10x	0.84	11.6	0.8	0.01	
Options:							
420.248	Spare battery type V394 (4 needed)						
910.408	LED ring light						

Peak stand microscopes 25x ... 100x

Compact and light-weight stand microscope with scale. The high resolution and bright images as well as its easy focusing make this instrument a practical measuring aid. A scale graduation (scale range 8 mm) has been engraved on the focusing ring which allows height measurements at a resolution of 0.1 mm. With detachable soft rubber eye adapter. Delivery in a case, with matching standard scale.

- Dimensions: $\varnothing 41.5 \times 122$ mm.
- Weight: 83 g.

MedioTehna

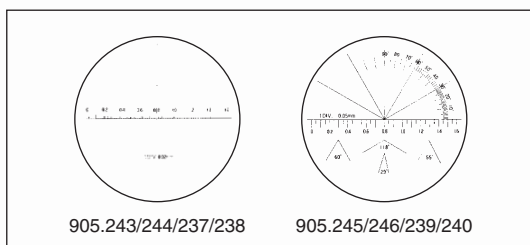

Item No.	Type	Magnification	Price HRK
Standard scales:			
905.243	24	25x	
905.244	13	50x	
905.237	34	75x	
905.238	44	100x	
Scales for inspection of printed matter and tools:			
905.245	25	25x	
905.246	14	50x	
905.239	35	75x	
905.240	45	100x	



905.250

Item No.	Magnification	Field of view \varnothing /mm	Working distance/mm	Measuring range/mm	Graduation mm	Price HRK
905.249	25x	3.3	17.0	3.0	0.05	
905.250	50x	2.0	11.7	1.6	0.02	
905.251	75x	1.1	11.7	1.0	0.01	
905.258	100x	0.84	11.6	0.8	0.005	

Robust Stand magnifier 5x with LED illumination

Robust stand magnifier with aluminum housing, LED illumination and a very large field of view.

- Field of view: $\varnothing 85$ mm.
- Lens diameter: $\varnothing 70$ mm.
- Illumination: 3 LEDs with 3 luminous intensity settings.
- Aluminum housing.
- Dimensions: $\varnothing 94 \times 52$ mm.
- Weight: 194 g.
- Delivery in a soft case with a micro fiber cleaning cloth and micro USB cable.
- Power supply: rechargeable battery with micro USB cable.

MedioTehna



Item No.	Magnification	Price HRK
910.254	5x	

Scale magnifier 10x with LED illumination

All-purpose scale magnifier with LED illumination and a large field of view.

- Field of view: $\varnothing 30$ mm.
- Measuring range standard scale: 30 mm.
- Graduation: 0.1 mm.
- Illumination: 8 LEDs.
- Dimensions: $\varnothing 45 \times 51$ mm.
- Weight: 106 g.
- For optional scales: see "Peak scales $\varnothing 35$ mm".
- Power supply: 4 batteries (V394).



Item No.	Description	Price HRK
910.319	Magnifier with standard scale in a case (for scales of $\varnothing 35$ mm)	
Option:		
420.248	Spare battery type V394 (4 needed)	

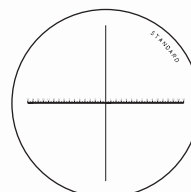

Magnifying glass 2-20x with LED illumination

Handy magnifying glass with LED illumination. This magnifying glass has two lenses. One big lens and a small lens in the handle.

- Magnification: 2x (108 x 63 mm) and 20x (ø21 mm).
- Illumination: 2 COB-LED strips (big lens) and 1 LED (small lens).
- Two luminous intensity settings.
- Dimensions: 136 x 96 mm, handle 115 mm.
- Weight (without batteries): 206 g.
- Delivery with a micro fiber cleaning cloth.
- Power supply: 3 batteries 1.5 V (AAA).



Item No.	Description	Price HRK
910.317	Magnifying glass 2-20x	
Option:		
497.914	Spare battery type AAA (3 needed)	

Magnifying glass 2-6x with LED and UV illumination

Handy magnifying glass with LED and UV illumination. This model of the classic magnifying glass has a lens-in-lens construction. In the big lens a smaller lens has been integrated which offers extra strong magnification.

- Magnification: 2x (ø85 mm) and 6x (ø21 mm).
- Illumination: switch between 3 LEDs and 1 UV LED.
- Weight (without batteries): 116 g.
- Dimensions: ø99 x 230 mm.
- Power supply: 3 batteries 1.5 V (AA).



Item No.	Description	Price HRK
910.318	Magnifying glass 2-6x	
Option:		
495.111	Spare battery type AA (3 needed)	

MedioTehna

Precision scale magnifiers 6x ... 12x

Precision scale magnifiers with parallax-free reading and black anodized aluminum open housing. The eyepiece can be removed to be used as a stand-alone magnifier.

- Precision aplanatic glass lenses.
- Adjustable for individual focus.
- Removable eyepiece.
- Scale accuracy $\pm(0.01 + L/1000)$ mm.
- Delivery in a plastic tube.



903.201



Item No.	Magnification	Scale length mm	Graduation mm	Graduation thickness/mm	Price HRK
903.200	6x	20	0.1	0.02	
903.201	8x	10	0.1	0.02	
903.202	10x	10	0.1	0.02	
903.203	12x	6	0.05	0.01	

Options:
 903.204 LED illumination
 498.823 Battery type V389 (3 needed)



903.204

Scales with guided magnifying glass

Stainless steel scales of up to 400 mm for precise measurement on different surfaces. Delivered with one black anodized aluminum 10x magnifier with parallax-free reading. An optional second sliding magnifier can be added to the scale. The optional LED illumination can be used on these magnifiers as well.

- Measuring range: 0-400 mm.
- Graduation: 0.1 mm.
- Graduation thickness: 0.02 mm.
- Accuracy: ± 0.02 mm.
- Delivery in a plastic case.

Item No.	Measuring range/mm	Scale length mm	Price HRK
903.205	100	150	
903.206	212	262	
903.207	300	350	
903.208	400	450	

Options:
 903.209 Second magnifier with slider
 903.204 LED illumination



903.205 + 903.209

Glass rulers L = 50 ... 300 mm

Very accurate glass rulers, made from clear glass with a 0.1 or 0.5 mm graduation. Ideal for checking the magnification accuracy of profile projectors and microscopes, as well as the table feed accuracy of measuring equipment.

- Graduation: 0.1 or 0.5 mm.
- Accuracy: $(1.5 + 2L/1000) \mu\text{m}$;
L = measuring length in mm.
- Material: sodium glass.
- Expansion coefficient: $8.6 \cdot 10^{-6}/^{\circ}\text{C}$.
- Thickness: 5 mm.
- Width: 30 mm.
- With serial number.
- Delivery in an aluminum carrying case with a manufacturer measuring report.

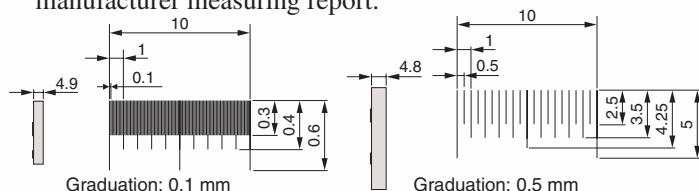

Item No.	Measuring range/mm	Graduation mm	Line thickness graduation/mm	Total length mm	Weight g	Price HRK
910.321	0- 50	0.1	0.01	80	29	
910.322	0- 50	0.5	0.1	80	29	
910.255	0- 100	0.1	0.01	130	47	
910.521	0- 100	0.5	0.1	130	47	
910.256	0- 200	0.1	0.01	230	83	
910.522	0- 200	0.5	0.1	230	83	
910.257	0- 300	0.1	0.01	330	119	
910.523	0- 300	0.5	0.1	330	119	

Electronic carbon scales for magnifier

- Measuring range: 0 - 1450 mm.
- Resolution: 0.01 mm.
- Intake magnifier: $\varnothing 41$ mm.
- mm/inch conversion.
- Proximity data output.
- Reset/preset.
- Excl. magnifier (905.180).
- Delivery in a wooden case with a manufacturer measuring report.
- Power supply: 1 battery type CR2032.

MedioTehna



Item No.	Measuring range/mm	Accuracy mm	Length mm/A	Weight kg	Price HRK
838.715	0- 450	± 0.03	720	1	
838.716	0- 750	± 0.03	1020	1.9	
838.717	0- 1150	± 0.05	1420	3	
838.718	0- 1450	± 0.06	1720	3.7	

Options:

- 495.157 Spare battery type CR2032
- 905.180 Magnifier with standard scale 905.181
- 996.664 Holder for Dino-Lite USB measuring microscopes¹



¹For Dino-Lite Edge models with normal working distance; magnification approx. 30x.

Light magnifiers with fluorescent or LED illumination

Large lens with a large field of view. Very suitable for production and assembly of precision instruments.

■ **Magnification:**

- 1.75x (3 dpt.): 909.648,
- 1.75x + 4x (3 dpt. + 12 dpt.): 909.649,
- 2.25x (5 dpt.): 909.650, 909.651.

- Lens: ϕ 100 mm + ϕ 20 mm: 909.649,
- ϕ 120 mm: 909.650, 909.651,
- ϕ 127 mm: 909.648.
- Span table clamp: 50 mm.
- Dimensions and weight base 910.430: 310 x 215 mm, 4 kg.
- Power supply: 230 V.



With circular fluorescent tube

Item No.	Description	Price HRK
909.650	With table clamp	
909.651	With base	
Option:		
909.654	Spare bulb 22 W	

With LED ring light

Item No.	Description	Price HRK
909.648	56 SMD-LEDs, with table clamp	
909.649	60 LEDs, with base	



Options (only for 909.648 and 909.650):

Item No.	Description	Price HRK
910.427	Table clamp	
910.428	Wall mount	
910.429	Table mount	
910.430	Base	

Stereo zoom microscopes with auxiliary lenses SSM-10/20

Stereo zoom microscopes with a sharp erect image and a large field of view. Equipped with a double objective (2x/4x is used the most; also available 1x/2x and 1x/3x), so that the magnification can be changed with a simple rotary motion. The magnification of the eyepieces is 10x (optionally 5x, 15x and 20x). The magnification can be adjusted to your application even more with an optional auxiliary lens (0.5x, 0.75x, 1.5x or 2x). For all accessories, please refer to the pages "SSM stereo microscope accessories".

- Stand with round (flattened) column and anti drop facility.
- Microscope head: 360° rotatable.
- Viewing angle: 45°.
- Interpupillary distance: adjustable (55 - 75 mm).
- Left eyepiece with diopter adjustment: ±5 dpt.
- Working distance (without aux. lens): 72 mm.
- Stage plate: black/white (two-sided).
- Delivery incl. dust cover and soft rubber eye adapters.

Item No.	Type	Magnification	Price HRK
909.006	SSM-10	20x/40x	
909.046	SSM-10	10x/20x	
909.036	SSM-10	10x/30x	
909.007 ¹	SSM-20C2	20x/40x	
909.047 ¹	SSM-20C2	10x/20x	
909.037 ¹	SSM-20C2	10x/30x	

¹ With LED illumination.
See for accessories the pages "SSM stereo microscope accessories".



MedioTehna



Illumination: LED incident light and LED backlight

Model SSM-20C2 is equipped with LED incident light and LED backlight, and the luminous intensity is adjustable.

- Stage plate: opal glass. Delivery incl. black/white stage plate.
- Power supply: 230 Vac (50 Hz).

Type		SSM-10	SSM-20C2
Eyepiece	M	10x	10x
Objective	M	2x/4x, 1x/2x or 1x/3x	
Total range*	M	5-160x, 2½-80x or 2½-120x	
Illumination		no	yes
Max. object height	mm	100	100
Travel of rack	mm	60	60
Stage plate	ø/mm	75	95
Dimensions	l×w×h/mm	260x170x290	270x235x330
Weight	kg	3.0	4.3

*The magnification range of the microscope in combination with the optional eyepieces 5-20x and auxiliary lenses 0.5-2x.



Stereo microscopes with stepless zoom SSM-E

Stereo zoom microscopes with a sharp erect image and a large field of view. The special microscope head is equipped with stepless zoom; in combination with the standard 10x eyepieces (optionally 20x) you can smoothly zoom in from 10x to 40x magnification. The magnification can be adjusted to your application even more with an optional auxiliary lens (0.5x, 0.75x, 1.5x or 2x). For all accessories, please refer to the pages “SSM stereo microscope accessories”.

- Stand with round (flattened) column and anti drop facility.
- Microscope head: 360° rotatable.
- Viewing angle: 45°.
- Interpupillary distance: adjustable (55 - 75 mm).
- Both eyepieces with diopter adjustment: ± 5 dpt.
- Working distance (without aux. lens): 85 mm.
- Equipped with LED incident light and LED backlight, and the luminous intensity is adjustable.
- Stage plate: opal glass.

- Delivery incl. dust cover, soft rubber eye adapters and black/white stage plate.
- Power supply: 230 Vac (50 Hz).

Item No.	Type	Magnification	Price HRK
909.010	SSM-EC2	10 - 40x	
908.998	SSM-3EC2	10 - 40x	

See for accessories the pages “SSM stereo microscope accessories”.



Type		SSM-EC2	SSM-3EC2
Eyeiece	M	10x	10x
Objective	M	1-4x	1-4x
Total range*	M	5-160x	5-160x
Illumination		yes	yes
Max. object height	mm	110	110
Travel of rack	mm	60	60
Stage plate	ø/mm	95	95
Dimensions	l x w x h / mm	330x235x360	330x235x395
Weight	kg	4.8	5.4



908.998

*The magnification range of the microscope in combination with the 10x eyepieces, the optional 20x eyepieces and the optional auxiliary lenses 0.5-2x.

Camera connection

Model 3EC2 is equipped with camera connection. See the accessories page for the total magnification range with camera.

SSM stereo microscope accessories

USB microscope cameras

For viewing and saving images. They fit in the ocular ($\phi 30$ mm) of an SSM microscope and/or the adapter bushing ($\phi 23$ mm) of the models SSM-3E/3EC2.

- Field of view: see table.
- Resolution: 1.3 Mpx or 5 Mpx.
- Suitable for Windows and Mac OS X.
- Measuring of distances, radii and angles.

Auxiliary lenses

The magnification can be adjusted to your application even more with an optional auxiliary lens. Note concerning stereo microscopes with a fixed stand: auxiliary lens 0.5x is not suitable, and with auxiliary lenses 1.5x and 2x focusing on the stage plate is not possible (the product needs to be positioned higher).



Pairs of eyepieces



Soft rubber eye adapters

Item No.	Description	Price HRK
909.089	Per pair	



MedioTehna



Item No.	Description	Price HRK
Pairs of eyepieces for SSM-2/3/5/10/20:		
909.050	$M=5x$	
909.051	$M=10x$	
909.052	$M=15x$	
909.053	$M=20x$	
Pairs of eyepieces for SSM-E:		
909.055	$M=10x$	
909.057	$M=20x$	
Eyepieces with crosshair for SSM-E:		
909.095	$M=10x$ (per piece)	
909.096	$M=20x$ (per piece)	
Auxiliary lenses (for SSM-10/20/E):		
909.018	$M=0.5x$	
909.019	$M=0.75x$	
909.020	$M=1.5x$	
909.021	$M=2x$	
USB microscope cameras:		
774.145	1.3 Mpx, $\phi 23$ mm	
774.296	1.3 Mpx, $\phi 23/30/30.5$ mm	
774.243	5 Mpx, $\phi 23/30/30.5$ mm	

Magnification objective	Microscope magnification / Field of view/mm			
	Eyepiece 5x	Eyepiece 10x	Eyepiece 15x	Eyepiece 20x
Stereo microscope SSM-2:				
2x	10x / $\phi 10.0$	20x / $\phi 10.0$	30x / $\phi 7.0$	40x / $\phi 5.0$
Stereo zoom microscope SSM-3/5:				
1x	5x / $\phi 20.0$	10x / $\phi 20.0$	15x / $\phi 15.0$	20x / $\phi 10.0$
2x	10x / $\phi 10.0$	20x / $\phi 10.0$	30x / $\phi 7.0$	40x / $\phi 5.0$
3x	15x / $\phi 7.0$	30x / $\phi 7.0$	45x / $\phi 5.0$	60x / $\phi 3.5$
4x	20x / $\phi 5.0$	40x / $\phi 5.0$	60x / $\phi 3.5$	80x / $\phi 2.5$
Stereo zoom microscope SSM-10/20 (without auxiliary lens):				
1x	5x / $\phi 20.0$	10x / $\phi 20.0$	15x / $\phi 15.0$	20x / $\phi 10.0$
2x	10x / $\phi 10.0$	20x / $\phi 10.0$	30x / $\phi 7.0$	40x / $\phi 5.0$
3x	15x / $\phi 7.0$	30x / $\phi 7.0$	45x / $\phi 5.0$	60x / $\phi 3.5$
4x	20x / $\phi 5.0$	40x / $\phi 5.0$	60x / $\phi 3.5$	80x / $\phi 2.5$

Magnification objective	Magnification / Field of view/mm		Field of view camera/mm		
	Eyepiece 10x	Eyepiece 20x	774.145	774.296	774.243
Stereo microscope with stepless zoom SSM-E (without auxiliary lens):					
from 1x to 4x	10x / $\phi 20.0$ 40x / $\phi 5.0$	20x / $\phi 10.0$ 80x / $\phi 2.5$	4.5 x 3.3 ¹ 1.2 x 0.8 ¹	6.8 x 5.0 ¹ 1.4 x 1.0 ¹	19.0 x 14.0 ¹ 2.7 x 2.0 ¹
from 1x to 4x				5.6 x 4.1 ² 1.34 x 1.0 ²	18.0 x 12.0 ² 2.4 x 1.8 ²

¹ Camera intake in adapter bushing.

² Camera intake in ocular.

SSM stereo microscope accessories (continued)

LED optical fiber illumination



Item No.	Description	Price HRK
LED optical fiber illumination:		
910.107	Light source LED, 20 W	
909.030	Single flexible arm	
909.028	Dual flexible arm	
909.029	Optical fiber ring light ^{1,2}	
Ring light^{1,2}:		
909.085	Ring light 60 LEDs	
Spare bulbs (standard illumination):		
499.377	For SSM-2/3/5	
498.157	For SSM-20W/EW and for transmitted light SSM-3E	
499.379	For incident light SSM-3E	
438.211	Fuse F 0.5 A, 250 V for SSM-2/3/5/20W/EW/3E	
Other options:		
909.022	Dark field condenser	
908.999	XY measuring table	
960.255	Dial indicator holder	
635.222	Field of view qualifier	

LED optical fiber ring light^{1,2}

Suitable for stereo microscopes SSM-10/20/E.
Note: not for use in combination with auxiliary lenses.



MedioTehna

Ring light^{1,2}

Suitable for SSM-10/20/E (909.085).

Dark field condenser

The contrast of transparent objects is enhanced. Suitable for all SSM stereo microscopes with backlight.

- Diameter: 94 mm.
- Stage: ø 27 mm.



XY measuring table

- Range: X, Y: 25 mm.
- Intake microscope: ø 94 mm.
- Turnable object plate with degree indication.
- Excl. two analog micrometer heads (intake ø 12 mm; 906.072 measuring range 25 mm).



¹ Delivery incl. adapter ring.

² Note: microscopes with standard provided incident light, this incident light must be removed before installing the ring light.



Dial indicator holder

Suitable for stereo microscopes with round column from the series SSM-10/20/E, for height measurements. The accuracy increases with higher magnification.

- Excl. dial indicator.
- The travel of the microscopes is 60 mm; see the dial indicators category for a suitable dial indicator with measuring range 50 or 60 mm.



Field of view qualifier

- Accuracy: ± 0.002 mm.

635.222



SSM stereo microscope accessories (continued)

Large stand

- Base: 255 x 255 mm.
- Column height: 390 mm.
- Arm length: 490 mm.
- Height adjustment: 60 mm.

MedioTehna



908.997

Stand with illumination

Equipped with LED incident light and back-light. The luminous intensity is adjustable.

- Column height: 185 mm.



909.405

LCD microscope head

- Screen: 8" color.
- CCD: 1/3" color.
- Zoom lens: 0.65 - 5.5.
- Magnification: 10 - 85x.
- Working distance: 10.5 cm.
- Crosshair can be toggled on/off.
- Field of view: from 1.3 x 1.8 mm ($M=85x$) to 12 x 16 mm ($M=10x$).



909.406

Microscope heads

- With or without camera connection.



909.093



909.092



909.405
+ 909.406
+ 870.006
+ 334.695



Item No.	Description	Price HRK
Microscope stands:		
908.997	Large stand	
909.405	Stand with illumination	
870.006 ¹	Column 400 mm	
Microscope heads:		
909.092	Microscope head	
909.093	Microscope head with camera connection	
909.406 ²	LCD microscope head	
334.695	Mini AC adapter 12 Vdc, 1 A	

¹ To be used with stand 909.405 for a larger Z axis range.

² Adapter 334.695 required.

Industrial endoscope

Industrial endoscope for inspecting hard-to-reach places by means of a flexible cable. Equipped with built-in illumination.

With the endoscope images can be watched on the integrated LCD color display. With a MicroSD card photos and videos can be made and saved.

- Automatic switch-off.
- Bendable camera cable: \varnothing 5.5 mm.
- Cable length: 1 m.
- Field of view: 70°.
- Focus distance: 30-60 mm.
- Camera resolution: 1.0 Mpx HD.
- Camera IP67.
- 5" LCD color display 720P HD.
- Video resolution: 1280 x 720 px.
- Photo resolution: 1920 x 1080.
- 2x digital zoom.
- 180° rotatable image.
- Illumination: 6 LEDs, intensity adjustable.
- Flashlight in the handle.
- Delivery with 45° mirror, magnet and hook.
- Delivery in a plastic carrying case.
- Power supply: 1 rechargeable lithium battery 3.7 V, 5000 mAh.
- USB charging cable included.



910.170

Item No.	Camera \varnothing /mm	Cable \varnothing /mm	Cable length/m	Price HRK
910.170	5.5	5	1	
Options:				
910.172* Cable length 1 m				
910.176* Mirror, magnet and hook				

* Standard included.

LED optical fiber illumination

Consists of LED cold light source and fiber optic light guide with single or double arm gooseneck flexible arm. The adjustable flexible arm and adjustable brightness level give you the right angle of illumination and lighting of the product for every situation.



Item No.	Description	Price HRK
910.107	Light source LED, 20 W	
909.030	Single flexible arm	
909.028	Dual flexible arm	

Special cleaner

Special cleaner (120 ml) for objectives, glass plates and other optical components.



Item No.	Description	Price HRK
111.534	Special cleaner	

Field of view qualifier

Glass reference standard with a pattern consisting of wide variety of very accurate optical characteristics, produced with a coating (chrome). Very suitable for use with optical instruments as geometric accuracy standard or as a test and training object.

- Accuracy: ± 0.002 mm.
- Delivery including drawing with size indication.



Item No.	Description	Price HRK
635.222	Field of view qualifier	

Optical cleaning kit

This cleaning kit is ideal to clean optics, microscopes and magnifying glasses, but can also be used on other products.

The set consists of:

- a bottle of cleaning solution (15 ml),
- a micro fiber cleaning cloth,
- a soft brush,
- an air blower.



Item No.	Description	Price HRK
909.432	Optical cleaning kit	

Graduated rulers / Scale units / Circumference tapes Precision tapes / Distance meters



Accuracy of graduated rulers according DIN 2004/22		
Measuring range (mm)	Max. permissible errors (\pm mm)	
	EC I	EC II
0- 500	0.15	0.40
0- 1000	0.20	0.50
0- 1500	0.25	0.60
0- 2000	0.30	0.70
0- 3000	0.40	0.90
0- 4000	0.50	1.10

Accuracy of graduated rulers according DIN 866 form A/B		
Measuring range (mm)	Max. permissible errors (\pm mm)	
	form A	form B
0- 500	0.04	0.10
0- 1000	0.04	0.10
0- 1500	0.06	0.15
0- 2000	0.06	0.15
0- 3000	0.08	0.20
0- 4000	0.10	0.25
0- 5000	0.12	0.30

Precision rulers

- Measuring range: 0-3000 mm.
- Graduation: 1 mm.
- Material: bright steel or stainless steel.
- No graduation on first 5 mm at both ends.
- Accuracy and construction according DIN 866 form A.

MedioTehna



Dimensions <i>l x w x t</i> /mm	Bright steel		Stainless steel		Wooden case	
	Item No.	Price HRK	Item No.	Price HRK	Item No.	Price HRK
500 x 30 x 6	771.000		771.005		776.568	
1000 x 40 x 8	771.001		771.006		776.468	
1500 x 40 x 8	771.002 ¹		771.007 ¹		776.561 ¹	
2000 x 50 x 10	771.003 ¹		771.008 ¹		776.562 ¹	
3000 x 50 x 10	771.004 ¹		771.009 ¹			

¹ Delivery ex Groningen, Netherlands.

Precision rulers

- Measuring range: 0-3000 mm.
- Graduation: 1 mm.
- Material: bright steel or stainless steel.
- Zero coincides with left end.
- Accuracy and construction according DIN 866 form B.



Dimensions <i>l x w x t</i> /mm	Bright steel		Stainless steel		Wooden case	
	Item No.	Price HRK	Item No.	Price HRK	Item No.	Price HRK
500 x 25 x 5	771.010		771.015		776.568	
1000 x 30 x 6	771.011		771.016		776.468	
1500 x 30 x 6	771.012 ¹		771.017 ¹		776.561 ¹	
2000 x 40 x 8	771.013 ¹		771.018 ¹		776.562 ¹	
3000 x 40 x 8	771.014 ¹		771.019 ¹			

¹ Delivery ex Groningen, Netherlands.

Rulers

Rulers with beveled edge for parallax-free reading.

- Measuring range: 0-2000 mm.
- Graduation: 1 mm.
- Material: bright steel.
- Zero coincides with left end.
- With hanger hole.



910.216



Item No.	Dimensions <i>l</i> x <i>w</i> x <i>t</i> /mm	Price HRK
910.216	300 x 40 x 5	
910.217	500 x 40 x 5	
910.218	1000 x 40 x 5	
910.219 ¹	1500 x 40 x 5	
910.220 ¹	2000 x 40 x 5	

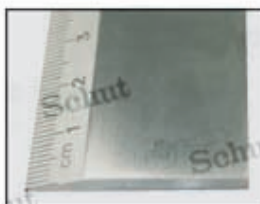

¹ Delivery ex Groningen, Netherlands.

Aluminum rulers

- Measuring range: 0-1000 mm.
- Graduation: 1 mm.
- Material: anodized aluminum.
- Zero coincides with left end.
- With hanger hole.



906.615



Item No.	Dimensions <i>l</i> x <i>w</i> x <i>t</i> /mm	Price HRK
906.615	300 x 50 x 5	
906.616	600 x 50 x 5	
906.617	1000 x 50 x 5	

Aluminum rulers

- Measuring range: 0-1000 mm.
- Graduation: 1 mm.
- Material: anodized aluminum.
- With hanger hole.



775.590



775.600

MedioTehna

Item No.	Dimensions <i>l</i> x <i>w</i> x <i>t</i> /mm	Price HRK
775.590	300 x 35 x 5	
775.592	600 x 35 x 5	
775.593	1000 x 35 x 5	
With handle and magnets:		
775.600	450 x 50 x 5	
775.602	1000 x 50 x 5	

Stainless steel rulers

- Measuring range: 0 - 2000 mm.
- Graduation: 1 mm.
- Matt chrome-plated stainless steel surface.
- With mm graduation on the upper edge.
- With 0.5 mm graduation on the lower edge.



Item No.	Dimensions l x w x t/mm	Price HRK
With mm/0.5 mm graduation:		
775.584	1000 x 35 x 1.2	
775.585	1500 x 40 x 2	
775.586 ¹	2000 x 40 x 2	
With mm/mm graduation:		
The first 100 mm on the lower edge have a 0.5 mm graduation.		
775.304 ¹	2000 x 41 x 2	

¹ Delivery ex Groningen, Netherlands.

Stainless steel rulers

- Measuring range: 0 - 1000 mm.
- Graduation: 1 mm on the front side on the upper and lower edges, 0.5 mm on the back side on the upper and lower edges.
- Matt chrome-plated stainless steel surface.
- EC class II.
- Etched graduation.



910.323



Item No.	Dimensions l x w x t/mm	Price HRK
910.323	300 x 30 x 1	
910.324	500 x 30 x 1	
910.325	1000 x 30 x 1	

Self-adhesive rulers

- Measuring range: 0 - 400 mm.
- Graduation: 1 mm, vernier: 0.1 mm.
- Blue anodized aluminum.
- With self-adhesive back.
- Suitable for positioning on measuring devices and machine elements.

Vernier 0.1 mm

- 10 scale divisions on 19 mm.
- Non-adhesive, furnished with two fixing holes \varnothing 2.5 mm.

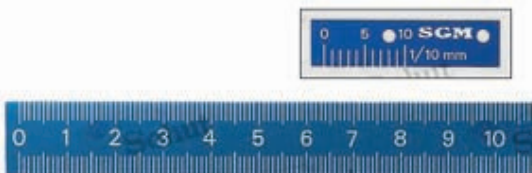

Item No.	Measuring range/mm	Dimensions l x w x t/mm	Price HRK
775.901	0 - 200	208 x 16 x 0.5	
775.902	0 - 300	308 x 16 x 0.5	
775.903	0 - 400	408 x 16 x 0.5	
775.900	Vernier 0.1 mm	40 x 10 x 0.5	

Stainless steel rulers with L → R or R → L numbering

- Measuring range: 0 - 12000 mm.
- Graduation: 1 mm (type B: 0.5 mm).
- Matt chrome-plated stainless steel surface.
- Etched graduation.
- EC class II (up to 4000 mm).
- Rulers from the main table with hanger hole.

Available on request:

- with graduation from top to bottom or from bottom to top,
- with different combinations (mm/mm, mm/inch, mm/blanc, etc.),
- with 0-point in the middle.
- Thickness: from 300 mm: 1 mm, from 500 mm: 2 mm.

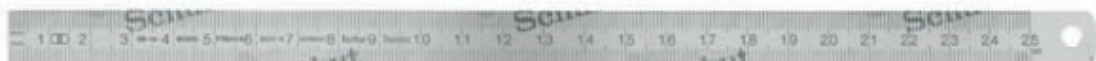

835.124

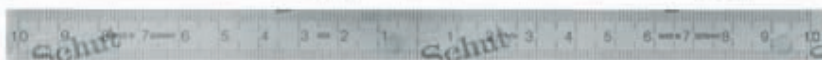

835.266



Item No.	Price HRK	Item No.	Price HRK	Item No.	Price HRK	Item No.	Price HRK	Dimensions l x w x t/mm
L → R type A:		R → L type A:		L → R type B:		R → L type B:		
835.120		835.121		835.421		835.422		150 x 13 x 0.5
835.122		835.123		835.298		835.440		200 x 13 x 0.5
835.124		835.125		835.427		835.441		250 x 13 x 0.5
835.126		835.127		835.129		835.442		300 x 13 x 0.5
835.130		835.131		835.354		835.443		500 x 18 x 0.5
835.132		835.133		835.252		835.444		1000 x 18 x 0.5
835.134		835.135		835.428		835.445		1500 x 18 x 0.5
835.136		835.137		835.429		835.446		2000 x 18 x 0.5
835.138		835.139		835.430		835.447		2500 x 18 x 0.5
835.140		835.141		835.431		835.448		3000 x 18 x 0.5
835.142		835.143		835.432		835.449		3500 x 18 x 0.5
835.144		835.145		835.433		835.450		4000 x 18 x 0.5
835.146		835.147		835.413		835.451		5000 x 18 x 0.5
835.148		835.149		835.434		835.452		6000 x 18 x 0.5
835.150		835.151		835.035		835.453		7000 x 30 x 1
835.152		835.153		835.435		835.454		8000 x 30 x 1
835.154		835.155		835.436		835.455		9000 x 30 x 1
835.156		835.157		835.437		835.456		10000 x 30 x 1
835.158		835.159		835.438		835.457		11000 x 30 x 1
835.160		835.161		835.439		835.458		12000 x 30 x 1

835.355



Type A: mm/mm (bottom and top side 1 mm graduation).

Type B: 0.5 mm/1 mm (top side 0.5 mm, bottom side 1 mm graduation).

Rulers with a self-adhesive back

Item No.	Additional costs	Price HRK
835.165	For rulers up to 1000 mm (price per piece) For rulers from 1000 mm (price per meter)	

The self-adhesive back is *not* separately available.

MedioTehna

With 0-point in the middle

Item No.	Dimensions l x w x t/mm	Price HRK
835.266	200 x 13 x 0.5	

Other sizes are also available.

Rulers

Stainless steel rulers with laser engraving

- With mm/mm graduation from left to right.
- Graduation: 1 mm.
- With identification number.
- EC class I.



835.462



Stainless steel rulers with magnet inserts

- Graduation from left to right.
- Laser engraving.
- With 2 flat edges without hanger hole.
- Graduation on front and back side.
- Graduation: front side: 1 mm, 0.5 mm, back side: 1/32", 1/64".
- With removeable magnet inserts.
- EC class II.

835.473

Rulers (black) with laser engraving

- Graduation on front and back side.
- Graduation: front side: 1 mm, 0.5 mm, back side: 1/10", 1/16", 1/20", 1/32", 1/64", 1/50", 1/100".
- EC class II.



835.466

Stainless steel rulers with 90° anvil hook

- Graduation from left to right.
- Laser engraving.
- Graduation: front side: 1 mm, back side: 0.5 mm.
- EC class II.



835.476

Item No.	Dimensions l x w x t/mm	Material	Class	Price HRK
Stainless steel rulers with laser engraving:				
835.096	150 x 13 x 0.5	Matt chrome-plated stainless steel surface	EC class I	
835.459	300 x 13 x 0.5	Matt chrome-plated stainless steel surface	EC class I	
835.460	500 x 20 x 0.5	Matt chrome-plated stainless steel surface	EC class I	
835.461	1000 x 20 x 0.5	Matt chrome-plated stainless steel surface	EC class I	
835.462	300 x 30 x 1.0	Matt chrome-plated stainless steel surface	EC class I	
835.463	500 x 30 x 1.0	Matt chrome-plated stainless steel surface	EC class I	
835.464	1000 x 30 x 1.0	Matt chrome-plated stainless steel surface	EC class I	
835.465	2000 x 30 x 1.0	Matt chrome-plated stainless steel surface	EC class I	
Rulers (black) with laser engraving:				
835.466	150 x 18 x 0.5	Steel, black surface	EC class II	
835.467	300 x 30 x 1.0	Steel, black surface	EC class II	
835.468	450 x 30 x 1.0	Steel, black surface	EC class II	
835.469	600 x 30 x 1.0	Steel, black surface	EC class II	
835.470	1000 x 30 x 1.0	Steel, black surface	EC class II	
Stainless steel rulers with magnet inserts:				
835.471	150 x 20 x 1.0	Matt chrome-plated stainless steel surface	EC class II	
835.472	300 x 30 x 1.0	Matt chrome-plated stainless steel surface	EC class II	
835.473	600 x 30 x 1.0	Matt chrome-plated stainless steel surface	EC class II	
835.474	900 x 30 x 1.0	Matt chrome-plated stainless steel surface	EC class II	
835.475	1200 x 30 x 1.0	Matt chrome-plated stainless steel surface	EC class II	
Stainless steel rulers with 90° anvil hook:				
835.476	200 x 13 x 0.5	Matt chrome-plated stainless steel surface	EC class II	
835.477	300 x 13 x 0.5	Matt chrome-plated stainless steel surface	EC class II	
835.478	500 x 18 x 0.5	Matt chrome-plated stainless steel surface	EC class II	

Digital horizontal scale units

These scale units are available in two different models. Up to 300 mm the model matches the photo of the 906.403, from 450 mm the photo of the 906.406.

- Measuring range: 0- 1000 mm.
- Resolution: 0.01 mm.
- Repeatability: 0.01 mm.
- mm/inch conversion.
- ABS/INC switchable (from 450 mm).
- On/off switch.
- Reset.
- Preset (from 450 mm).
- Max. measuring speed:
 <500 mm: 1.5 m/s,
 ≥500 mm: 1 m/s.
- Power supply:
 906.400- 403: 1 battery type V357,
 906.404- 409: 1 battery type CR2032.

Item No.	Measuring range/mm	Accuracy mm	Price HRK
906.400	0- 100	±0.03	
906.401	0- 150	±0.03	
906.402	0- 200	±0.03	
906.403	0- 300	±0.04	
906.404	0- 450	±0.05	
906.405	0- 500	±0.05	
906.406	0- 600	±0.05	
906.408	0- 800	±0.06	
906.409	0- 1000	±0.07	
Options:			
836.535	Spare battery type V357		
495.157	Spare battery type CR2032		

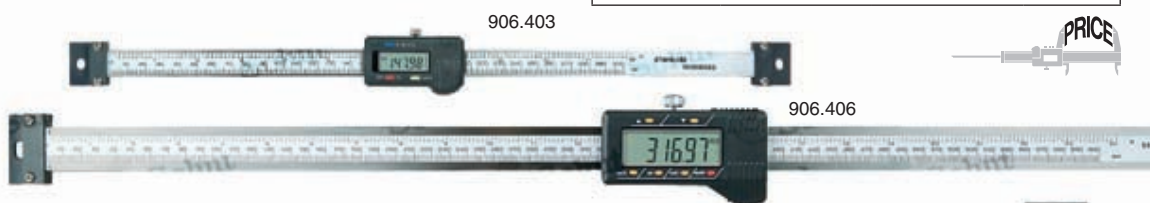

Digital vertical scale units

- Measuring range: 0- 1000 mm.
- Resolution: 0.01 mm.
- Repeatability: 0.01 mm.
- mm/inch conversion.
- ABS/INC switchable.
- On/off switch.
- Reset.
- Preset (from 500 mm).
- Max. measuring speed: 1 m/s.
- Power supply:
 1 battery type V357
 (except 906.416- 419).

Item No.	Measuring range/mm	Accuracy mm	Price HRK
906.415	0- 100	±0.03	
906.416	0- 150	±0.03	
906.417	0- 200	±0.03	
906.418	0- 300	±0.04	
906.419	0- 450	±0.05	
906.420	0- 500	±0.05	
906.421	0- 600	±0.05	
906.423	0- 800	±0.06	
906.424	0- 1000	±0.07	
Options:			
836.535	Spare battery type V357		
495.157	Spare battery type CR2032		

MedioTehna



906.417

Schwenk internal circumference tapes

Circumference tapes to measure the internal circumferences and the average cross-section of round and not-round bores. The surface may be smooth or rough.

- Separate graduations for circumference and diameter in mm.
- Vernier: 0.1 mm.
- Tape width: 20 mm.
- Graduation placed by laser.
- Universal clamp for all types.
- Delivery without clamping jaw.
- Stainless steel construction.



MedioTehna

NEW

Item No.	Diameter mm	Circumference mm	Price HRK
852.645	230- 490	720- 1550	
852.646	300- 700	940- 2200	
852.647	700- 1100	2190- 3460	
852.648	1100- 1500	3450- 4720	
852.770	1500- 1900	4710- 5980	
852.771	1900- 2300	5970- 7230	
852.262	2300- 2700	7220- 8500	
852.649	Clamping jaw		

Circumference tapes

- Separate graduations for circumference and diameter in mm.
- Vernier: 0.1 mm.
- Bright steel or stainless steel.
- Accuracy according EC class II.
- With manufacturer measuring report on request.



835.101

Bright steel

Item No.	Diameter mm	Circumference mm	Price HRK
835.111	20- 300	60- 950	
835.112	300- 700	940- 2200	
835.113	700- 1100	2190- 3460	
835.114	1100- 1500	3450- 4720	
835.115	1500- 1900	4710- 5980	
835.116	1900- 2300	5960- 7230	
835.117	2300- 2700	7220- 8500	
835.118	2700- 3100	8480- 9760	
835.119	3100- 3500	9730- 11010	

Stainless steel

Item No.	Diameter mm	Circumference mm	Price HRK
835.101	20- 300	60- 950	
835.102	300- 700	940- 2200	
835.103	700- 1100	2190- 3460	
835.104	1100- 1500	3450- 4720	
835.105	1500- 1900	4710- 5980	
835.106	1900- 2300	5960- 7230	
835.107	2300- 2700	7220- 8500	
835.108	2700- 3100	8480- 9760	
835.109	3100- 3500	9730- 11010	

Circumference tapes

- Separate graduations for circumference and diameter in mm.
- Vernier: 0.1 mm.
- Tape width: 13 mm.
- Stainless steel with yellow plastic coating for easy reading.
- Accuracy according EC class II.



NEW



Stainless steel with yellow plastic coating

Item No.	Diameter mm	Circumference mm	Price HRK
841.468	20- 300	60- 950	
841.469	20-1200	60- 3780	
841.470	20-2400	60- 7540	
841.471	20-3600	60-11310	

Stainless steel

Item No.	Diameter mm	Circumference mm	Price HRK
841.663	20- 300	60- 950	
841.664	20-1200	60- 3780	
841.665	20-2400	60- 7540	
841.666	20-3600	60-11310	

Circumference tapes for diameters

Circumference tapes for measuring of diameters.

- Graduation for diameter in mm.
- Vernier: 0.02 mm.
- Total tape width: 13 mm.
- Bright steel.



Item No.	Diameter mm	Price HRK
910.181	15- 50	
910.182	50- 300	
910.183	300- 600	
910.184	600- 900	
910.185	900-1200	
910.186	1200-1500	
910.187	1500-1800	
910.188	1800-2100	
910.189	2100-2400	
910.190	2400-2700	
910.191	2700-3000	

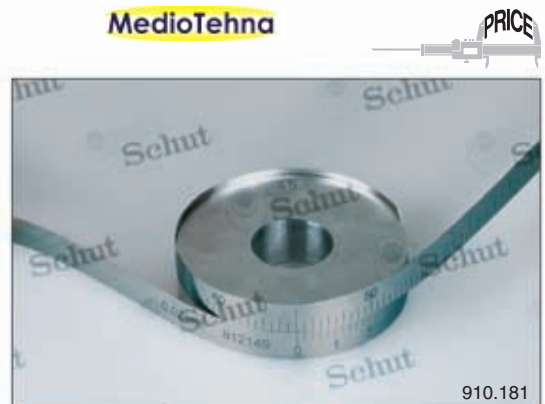

Precision tape for circumference and diameter

Precision tape for measuring of circumference and diameters.

- Separate graduations for circumference and diameter in mm.
- Graduation: 1 mm.
- Tape width: 12.5 mm.
- Lock.
- EC class II.
- White varnished very flexible steel strip with mm graduation.



NEW



Item No.	Diameter mm	Circumference mm	Price HRK
911.183	20-960	60-3000	



Schwenk length measuring tapes for plane parallel distances

Length measuring tapes for measuring plane parallel distances. The high contrast graduation has been placed by means of a laser.

- Graduation: 0.1 mm.
- Tape width: 20 mm.
- Tape thickness: 0.5 mm.
- Stainless steel construction.



MedioTehna

NEW

Item No.	Measuring range/mm	Price HRK
852.734	60- 950	
852.735	940-2200	
841.589	2190-3460	
841.590	3450-4720	
841.591	4710-5980	
841.592	5970-7320	



Precision tapes

Cost effective rubberized precision tapes.

- Yellow varnished steel strip with mm graduation.
- One-sided printed blade.
- Matt finished steel blade.
- EC class II.

- Standard EC-type hook.
- Lock.
- Standard packing of 12 pieces per carton box (except 910.060: 10 pieces).



MedioTehna



Item No.	Length m	Tape width mm	Price HRK
Precision tapes per piece:			
910.056	2	16	
910.057	3	16	
910.058	5	19	
910.059	8	25	
910.060	10	25	

Precision tapes with magnetic dual hook

Precision tapes for professional use with double-sided printed blade and double hook with magnet.

- EC class II (except 910.064).
- EC class I (only 910.064).
- Shockproof til 2 m.

- Matt finished steel blade.
- Double-sided printed blade (except 910.064).
- Blade horizontal stand-out:
19 mm: 1.7 m, 27 mm: 2.8 m.
- EC-type magnet dual hook (except 910.064).
- Lock.
- Extra lock on the bottom-side (except 910.064).
- Standard packing of 10 pieces per carton box.

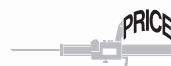

Item No.	Length m	Tape width mm	Price HRK
Precision tapes per piece:			
910.061	3	19	
910.062	5	27	
910.063	10	27	
EC class I:			
910.064	3	19	

Long stroke precision tape

Long stroke precision tape with blade from fiberglass and with high speed retracting gear.



- Double-sided printed blade.
- Graduation: 2 mm.
- EC class II.



Item No.	Length m	Tape width mm	Price HRK
910.065	30	15	

Long stroke precision tapes

- Black plastic housing with wristlet.



MedioTehna

775.540

- White varnished steel strip with mm graduation.
- Wind-up handle.
- EC class II.

Item No.	Length m	Tape width mm	Price HRK
775.540	10	9.5	
775.541	15	9.5	

Digital measuring tape

Digital measuring tape equipped with a 19 mm wide tape, which is provided with a clear graduation. The digital indication is convertible from external to internal measurements and can be reset to zero at any point on the tape.



- Measuring range: 0 - 5 m.
- Resolution: 1 mm.
- mm/inch conversion.
- Hold function.
- Reversal of display value.
- Automatic stop.
- Convertible for internal/external measurements.
- Storage for 8 measuring values.
- Dimensions: 75 x 70 mm.
- Power supply: 1 battery type CR2032.

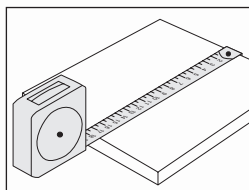
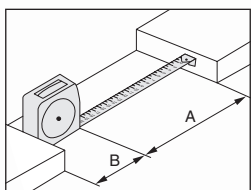

Item No.	Length m	Tape width mm	Price HRK
909.341	5	19	
Option: 495.157 Spare battery type CR2032			

Laser distance meters

With these compact hand laser distance meters you aim a visual laser spot at the object for quick and accurate measurements of the distance without contact.

- Measuring range: 0- 80 m.
- Resolution: 0.001 m/0.01 m.
- Accuracy: ± 2 mm.
- Distance, surface and volume measurements, continuous measurements, addition and subtraction, min/max function and Pythagoras function.
- mm/inch/ft conversion.
- Illuminated LCD display.
- On/off switch, automatic switch-off.
- Measurement reference: front or rear.
- Storage for 99 measuring values.
- With thread for tripod: UNC 1/4"-20, thread depth: 6 mm.
- Laser: 635 nm, class II according IEC 60825-1.
- Dimensions: 120 x 55 x 30 mm.
- Weight: 909.453: 180 g, 909.454: 128 g.
- With vial.
- Delivery in a carrying bag.
- Power supply: 2 batteries type AAA.



909.454

MedioTehna

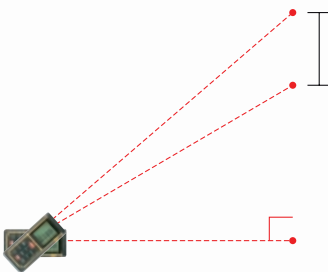
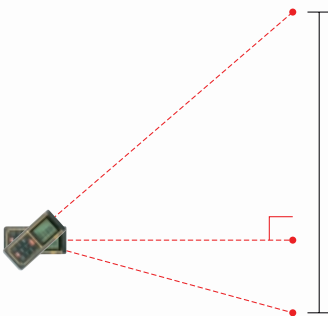

Pythagoras function



Item No.	Measuring range/m	Price HRK
909.453	0 - 40	
909.454	0 - 80	
Option:		
497.914	Spare battery type AAA	

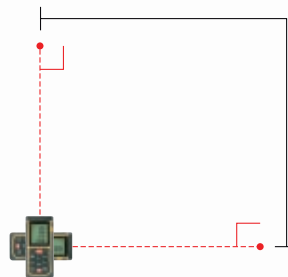

Surface function



Scribing tools / Compasses / Center squares



Marking gauges

- Measuring range: 0 - 400 mm.
- Vernier: 0.1 mm.
- Matt chrome-plated beam.
- Roll stop.



MedioTehna



Item No.	Measuring range/mm	Price HRK
836.602	0 - 200	
836.604	0 - 400	
836.603	Spare scriber point	

Marking gauges

- Measuring range: 0 - 500 mm.
- Vernier: 0.1 mm.
- With round rod and mm graduation.



907.187

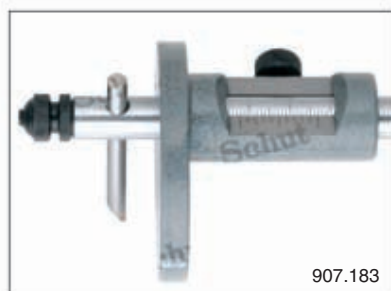

907.183

Item No.	Measuring range/mm	Price HRK
Without fine adjustment:		
907.183	0 - 200	
907.184	0 - 300	
907.185	0 - 400	
907.186	0 - 500	
With fine adjustment:		
907.187	0 - 200	
907.188	0 - 300	
907.189	0 - 400	
907.190	0 - 500	
907.191	Spare scriber point (TC)	

Marking calipers

T-shaped stainless steel marking caliper with a large marking face/cross scale. The marking face is sunk into the U-shaped base face.

- Measuring range: 0- 300 mm.
- Locking screw.
- Vernier: 0.05 mm.
- With or without fine adjustment.
- Matt chrome-plated beam.
- Marking face/cross scale with mm graduation (50-0-50 mm).

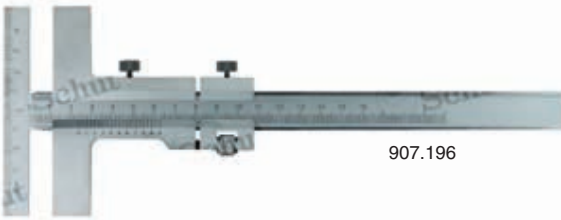

MedioTehna



Item No.	Measuring range/mm	Base length/mm	Price HRK
Without fine adjustment:			
907.575	0-160	140	
907.576	0-250	140	
907.577	0-300	160	
With fine adjustment:			
907.196	0-160	140	
907.197	0-250	140	
907.198	0-300	160	

Marking gauges

- Measuring range: 0- 300 mm.
- Vernier: 0.1 mm.
- Matt chrome-plated beam.



907.180



Item No.	Measuring range/mm	Price HRK
907.180	0-200	
907.181	0-250	
907.182	0-300	

Digital marking gauge and protractor

- Measuring range: 0- 300 mm.
- Resolution: protractor: 0.05°, scale: 0.01 mm.
- mm/inch conversion.
- On/off switch.
- Automatic switch-off.
- Reset.
- Hold function.
- Locking screw.
- Protection: IP40.
- Power supply: 1 battery type CR2032.



Item No.	Measuring range/mm	Price HRK
906.669	0-300	
Option:		
495.157	Spare battery type CR2032	

Scriber



MedioTehna



Item No.	Description	Price HRK
909.388	Scriber with clip, with tungsten carbide exchangeable point and magnetic upper part	
Replacement point:		
909.389	1 tungsten carbide scriber point for 909.388	

Trammels

- Round rod with graduation.
 - Milled key groove.
 - Vernier: 0.1 mm.
 - Fine adjustment.
- (Also available without fine adjustment.)



Item No.	Length/mm	Price HRK
671.275	500	
671.276	1000	
671.277 ¹	1500	
671.278 ¹	2000	
Needles per pair:		
671.234	Hardened steel	
671.239	Tungsten carbide	

¹ Delivery ex Groningen, Netherlands.

Trammels

- Flat beam with graduation.
- Vernier: 0.1 mm.
- Fine adjustment.
- Stainless steel construction.

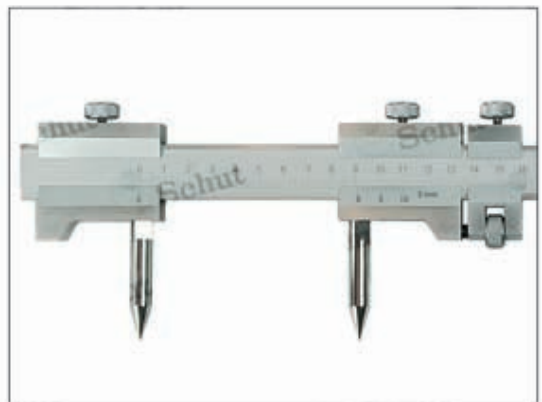

Item No.	Length/mm	Price HRK
671.261	500	
671.262	1000	
671.263 ¹	1500	
671.264 ¹	2000	
Needles per pair:		
671.230	Hardened steel	
671.235	Tungsten carbide	

¹ Delivery ex Groningen, Netherlands.

Spring joint dividers

- Stainless steel construction.
- With adjustment screw.
- With interchangeable points (910.012-018, 907.447-448).
- With pencil holder (907.447-448).



907.447

Item No.	Description	Price HRK
907.446	Spare divider point $\varnothing 2 \times 30$ mm	

Length/mm	Item No.	Price HRK	Item No.	Price HRK	Item No.	Price HRK
100	910.252		910.012		–	
125	910.253		910.013		–	
150	907.827		910.014		907.447	
175	–		910.015		–	
200	907.828		910.016		907.448	
250	907.829		910.017		–	
300	907.830		910.018		–	
400	907.831		–		–	
500	907.832		–		–	
600	907.833		–		–	

Firm joint compasses

- Stainless steel construction.
- With adjustment arch and locking screw (907.818-826, 909.461-469).
- With pencil holder (909.461-469).



MedioTehna



909.465

Length/mm	Item No.	Price HRK	Item No.	Price HRK	Item No.	Price HRK
150	907.809		907.818		909.461	
200	907.810		907.819		909.462	
250	907.811		907.820		909.463	
300	907.812		907.821		909.464	
400	907.813		907.822		909.465	
500	907.814		907.823		909.466	
600	907.815		907.824		909.467	
800	907.816		907.825		909.468	
1000	907.817		907.826		909.469	

Internal spring joint compasses

- Stainless steel construction.
- With adjustment screw.

MedioTehna



Item No.	Length/mm	Price HRK
907.793	100	
907.794	125	
907.795	150	
907.796	200	
907.797	250	
907.798	300	
907.799	400	
907.800	500	

External spring joint compasses

- Stainless steel construction.
- With adjustment screw.



Item No.	Length/mm	Price HRK
907.801	100	
907.802	125	
907.803	150	
907.804	200	
907.805	250	
907.806	300	
907.807	400	
907.808	500	

Firm joint compasses

- Stainless steel construction.



Item No.	Length/mm	Price HRK
907.836	100	
907.837	125	
907.838	150	
907.839	200	
907.840	250	
907.841	300	
907.842	400	
907.843	500	
907.844	600	
907.845	800	
907.846	1000	

Firm joint compasses

- Stainless steel construction.



Item No.	Length/mm	Price HRK
907.847	100	
907.848	125	
907.849	150	
907.850	200	
907.851	250	
907.852	300	
907.853	400	
907.854	500	
907.855	600	
907.856	800	
907.857	1000	

Center squares

Center squares with mm graduation on the blade, to mark the center on round discs or axes.

- Stainless steel construction, no-glare chrome finished.
- Graduation placed by means of a laser.

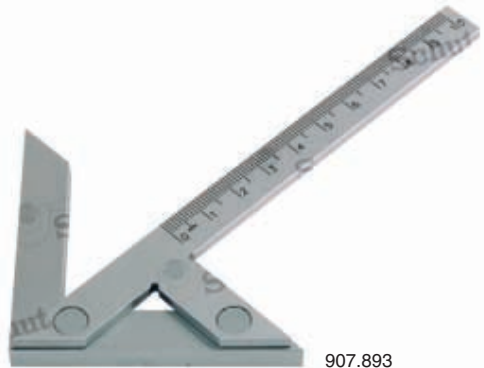

907.893

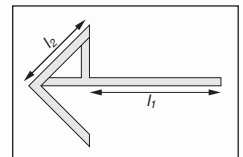

Item No.	Length/mm		Max. ϕ mm	Price HRK
	l_1	l_2		
907.893	100	70	90	
907.894	150	130	190	
907.895	200	150	220	
907.896	250	160	230	
907.897	300	180	280	
909.972	400	250	380	
909.973	500	330	530	

Caliper compasses

- For scribing of diameters of 0-600 mm.
- Vernier: 0.1 mm.
- Stainless steel construction, matt chrome-plated.
- Fixed jaw and beam made out of one piece.
- Hardened, ground and lapped measuring faces.



909.425

Item No.	For scribing up to ϕ /mm	Meas. range mm	Jaw length mm	Price HRK
909.424	300	150	40	
909.425	400	200	40	
909.426	500	250	40	
909.427	600	300	40	

MedioTehna

Universal setting instrument

This versatile instrument is specially designed for manufacturers of very accurate products, such as gauges and toolmakers. The guide is installed under an angle of 20° and the components can be moved very accurately. The movable component has several threaded bores M4, by which the setting instrument also can be used as a scriber or height gauge.

- Max. height range incl. extensions: 270 mm.
- Dimensions: 133 x 64 x 18.5 mm.
- Delivery with extensions 25 mm and 75 mm (equipped with thread M4/thread hole M4).
- Base with vial.



906.455

Item No.	Description	Price HRK
906.455	Universal setting instrument	

Surface gauge

Stable foot with V-slot at the ground surface, grips at the side and is also equipped with two bores (ø5.5 mm).

- Foot ground all around (except for the V-slot).
- Fine adjustment.
- Dimensions:
 scriber: ø 4 x 200 mm,
 arm: ø 10 x 450 mm,
 foot: 85 x 65 x 25 mm.

MedioTehna



Item No.	Description	Price HRK
906.220	Surface gauge	

Height and scribing gauges / Height gauges



Digital height and scribing gauges

- Measuring range: 0- 1000 mm.
 - Resolution: 0.01 mm.
 - mm/inch conversion.
 - ABS/INC switchable.
 - On/off switch.
 - Reset.
 - Hold function.
 - Fine adjustment.
 - Delivery incl. scriber.
 - Delivery in a plastic carrying case.
 - Power supply:
909.244/245/246: 1 battery type V357,
906.267/268: 1 battery type CR2032.
- From measuring range 500 mm:**
- Tolerance function.
 - Preset.



MedioTehna



Item No.	Measuring range/mm	Accuracy mm	Price HRK
906.267	0- 200	±0.03	
906.268	0- 300	±0.04	
909.244	0- 500	±0.05	
909.245	0- 600	±0.07	
909.246 ¹	0-1000	±0.07	

Options:

- 836.535 Spare battery type V357
- 495.157 Spare battery type CR2032
- 906.029 Scriber for 906.267
- 906.049 Scriber for 906.268
- 906.054 Scriber for 909.244/245
- 906.077 Scriber for 909.246

¹ Delivery ex Groningen, Netherlands.

Absolute digital height and scribing gauges

Digital height and scribing gauges with an absolute measuring system. Combined with a Digimatic dial indicator quick and accurate measurements can be performed with a constant measuring force.

- Measuring range: 0-600 mm.
- Resolution: 0.01 mm.
- Handwheel drive for easy head displacement.
- Interchangeable scriber, intake 9 x 9 mm.
- ABS/INC switchable.
- Digimatic data output.
- On/off switch.
- Reset.
- Hold function.
- Locking screw.
- Delivery incl. scriber, dial indicator holder and Digimatic data cable for dial indicator.
- Delivery in a plastic carrying case.
- Power supply: 1 battery type CR2032.
- For suitable Digimatic dial indicators refer to the dial indicators elsewhere in this catalog.

USB interface:

- For data transfer to PC (e.g. Excel, Word).
- Operating system: Windows and other.
- PC connection: USB.
- No software or driver to install.
- Foot switch (optional).



910.096
Delivery without dial indicator.



910.096



909.686



909.687



910.039/038

Item No.	Measuring range/mm	Accuracy mm	Price HRK
910.096	0-300	0.03	
910.097	0-600	0.05	

With Bluetooth:

910.098	0-300	0.03	
---------	-------	------	--

Options:

- 495.157 Spare battery type CR2032
- 909.686* USB interface
- 909.687 Footswitch for USB interface
- 910.038 Wireless USB receiver
- 910.039 Wireless transmitter
- 906.256 Scriber

*Standard configured for PC with English (US) keyboard. Also available on request for alternative keyboards.

PRICE

Digital height and scribing gauges with dial indicator holder

Solid and stable instruments with integrated dial indicator holder and stainless measuring table.

- Measuring range: 0 - 500 mm.
- Resolution: 0.01 mm.
- mm/inch conversion.
- ABS/INC switchable.
- On/off switch.
- Preset.
- Reset.
- Hold function.
- Tolerance function.
- Fine adjustment.
- Intake scriber: 8 x 6 mm.
- Delivery incl. scriber.

MedioTehna

- Dial gauge clamping shaft 8 mm.
- Measuring table: 906.115/116: 80 x 80 mm, 906.117: 110 x 100 mm.
- Power supply: 1 battery type V357.



Item No.	Measuring range/mm	Accuracy mm	Price HRK
906.115	0 - 200	±0.04	
906.116	0 - 300	±0.04	
906.117	0 - 500	±0.06	

Options:

- 836.535 Spare battery type V357
- 906.343 Scriber



Digital double columns height and scribing gauges

This is a very stable digital height gauge because of its twin guide system. The measuring unit moves over two independent columns with high precision toothed racks, which generates an accurate measurement.

- Measuring range: 0 - 600 mm.
- Resolution: 0.01 mm.
- Repeatability: 0.01 mm.
- Handwheel drive for easy head displacement.
- mm/inch conversion.
- ABS/INC switchable.
- On/off switch.
- Reset/preset.

- Intake scriber: 9 x 9 mm.
- Delivery incl. scriber.
- Power supply: 1 battery type V357.



Item No.	Measuring range/mm	Accuracy mm	Price HRK
906.263	0 - 300	±0.04	
906.264	0 - 450	±0.05	
906.265	0 - 600	±0.05	

Option:

- 836.535 Spare battery type V357
- 906.118 Scriber 9 x 9 mm



Height and scribing gauges with dial and counter

- Measuring range: 0 - 1000 mm.
- Graduation dial indicator: 0.01 mm.
- Resolution counter: 1 mm.
- 1 pointer revolution = 1 mm.
- Rotatable dial.
- Double counter, one indicator in plus direction and one in minus direction.
- Zero setting possible at any height.
- Intake scriber: 9 x 9 mm.
- Delivery incl. scriber.



Item No.	Measuring range/mm	Accuracy mm	Price HRK
906.250	0- 300	±0.04	
906.251	0- 450	±0.05	
906.252	0- 600	±0.05	
906.253	0- 800	±0.06	
906.254 ¹	0-1000	±0.07	
Option:			
906.174	Scriber 9 x 9 mm		

¹ Delivery ex Groningen, Netherlands.



Height and scribing gauges with dial

These height gauges are equipped with a rack, as used for dial calipers.

- Measuring range: 0 - 300 mm.
- Graduation: 0.02 mm.
- 1 pointer revolution = 2 mm.
- Rotatable dial.
- Fine adjustment.
- Delivery in a wooden case with a scriber.

MedioTehna



Item No.	Measuring range/mm	Accuracy mm	Price HRK
906.260	0 - 150	±0.03	
906.261	0 - 200	±0.03	
906.262	0 - 300	±0.04	
Options:			
906.029	Scriber for 906.260/261		
906.049	Scriber for 906.262		



Height and scribing gauges

- Measuring range: 0 - 1000 mm.
- Vernier: 0.02 mm.
- Fine adjustment.
- Delivery incl. scriber.
- Matt chrome-plated scale and vernier.



Item No.	Measuring range/mm	Accuracy mm	Price HRK
906.325	0 - 200	±0.03	
906.326	0 - 300	±0.04	
906.327	0 - 500	±0.05	
906.328 ¹	0 - 1000	±0.07	
Options:			
906.029	Scriber for 906.325		
906.049	Scriber for 906.326		
906.054	Scriber for 906.327		
906.748	Scriber for 906.328		

¹ Delivery ex Groningen, Netherlands.

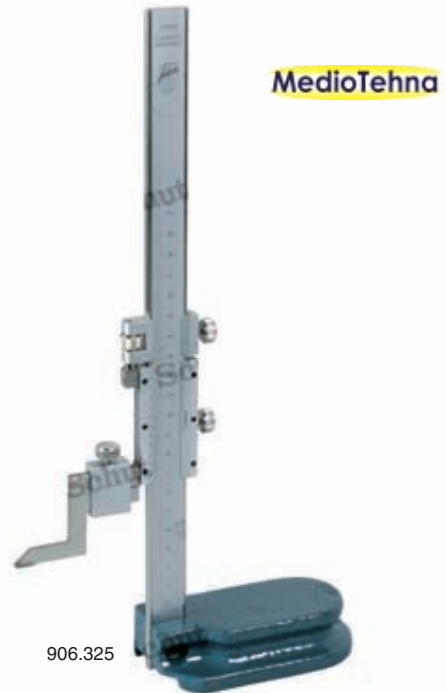

Height and scribing gauges with magnifier

To minimize the possibility of reading errors these height gauges are equipped with a magnifier. The magnifier can be adjusted in height, so that it can always be positioned correctly with regard to the vernier.

- Measuring range: 0 - 500 mm.
- Vernier: 0.02 mm.
- Ruler adjustable in height.
- Fine adjustment.
- Intake scriber: 9 x 9 mm.
- Delivery incl. scriber.



Item No.	Measuring range/mm	Accuracy mm	Price HRK
906.255	0 - 300	±0.04	
906.257	0 - 500	±0.05	
Options:			
906.269	Scriber for 906.255		
906.323	Scriber for 906.257		



Granite surface plate with stand for height gauges

Correct and accurate use of height gauges demand a robust and flat working table. Especially in combination with the very advanced and accurate Mitutoyo and TESA height gauges this is a necessity in order to benefit the full potential of these instruments.

In combination with the purchase of a TESA or Mitutoyo height gauge, Schut Geometrical Metrology offers granite surface plate and stand sets in various dimensions and accuracy classes for very competitive prices. Combinations that make the purchase of one of these height gauges even more attractive!

MedioTehna

Digital protractor

Compact digital protractor to attach to a caliper or height gauge.

- Measuring range: 180°.
- Resolution: 0.01° or 1'.
- Accuracy: ±5'.
- Digimatic data output.
- On/off switch.
- Automatic switch-off (adjustable).
- Preset or hold function.
- Reset.
- Reversible measuring direction.
- Weight: 160 g.
- Delivery in a case including assembly key, mounting bracket (clamping shaft 9 x 9 mm) and clamping screw for height gauge.
- Power supply: 2 batteries type AAA.



Item No.	Description	Price HRK
855.803	Digital protractor	
Options:		
497.914	Spare battery type AAA (2 needed)	
905.338	Digimatic cable, 1 m	
905.409	Digimatic cable, 2 m	

The stands are very robust and the support of the surface plate is determined on the basis of the Bessel points. All sets are available in surface plate sizes from 630 x 630 mm up to 2000 x 1000 mm, all according DIN 876, accuracy classes 1, 0 en 00.

Check our website www.Schut.com for the most recent promotions and prices.



131.101 +
131.113 +
131.108 +
402.028

With the purchase of a height gauge:

UNIQUE SET PRICES

Surface plate 1000 x 630 x 150 mm, class 0 including **stand: HRK**

Surface plate 1000 x 630 x 150 mm, class 0 including **stand, slide protection, cover, chest of drawers and cleaner: HRK**

Delivery ex Groningen, Netherlands

Granite plate cleaner

Special granite plate cleaner to keep the surface of your granite surface plate clean and useable for a long period. Dust, dirt, grease stains, finger and hand prints can easily be removed. A clean and smooth surface provides low friction, less wear and the most accurate measurements. The non-corrosive property of the cleaner prevents corrosion damage to metal products.



Item No.	Description	Price HRK
407.304	Cleaner, 500 ml	

Hardness testers / Thickness gauges / Thermometers
Tachometers / Dynamometers / Inspection instruments



Portable Shore hardness testers

Portable hardness testers to measure Shore hardness A or D, according to DIN ISO 48-4 and ISO 868.

- Measuring range: 0-100 Shore.
- Analog: graduation 1 Shore, digital: resolution 0.1 Shore.
- Measuring length: 2.5 mm.
- Material thickness: ≥6 mm.
- Delivery in a plastic case.

Analog

- Dial diameter: 57 mm.
- Dimensions: 110 x 58 x 30 mm.
- Weight: 230 g.

Digital

Integrated sensor and equipped with comfortable buttons. Possibility for display of current, average and maximum measuring value.

- Accuracy: ±1 Shore.
- RS232C data output.
- On/off switch.
- Automatic switch-off.
- Max function.
- Calculation of the average of at most 9 measurements in "max mode".
- Dimensions: 161 x 65 x 28 mm.
- Delivery with a manufacturer measuring report.
- Power supply: 2 batteries type AAA.

MedioTehna

909.066



Item No.	Type	Meas. range/Shore	Price HRK
Analog:			
907.882	Shore A	20- 90	
907.889	Shore D	20- 90	
Digital:			
909.066	Shore A	0-100	
909.068	Shore D	0-100	
Options:			
497.914	Spare battery type AAA (2 needed)		
909.078	RS232C cable and software		
909.430*	Shore A (approx. 30-90) 6 pieces test block set 50 x 50 x 7.5 mm		
909.431*	Shore D (approx. 15-90) 3 pieces test block set 50 x 50 x 7.5 mm		

*Delivery with a declaration of conformity.

Type	Shore A	Shore D
Max. spring force	8.065 N	44.50 N
Impact module		
Applications	Soft rubber, elastomers, nature rubber, etc.	Hard rubber, thermoplastics, etc.



907.882



909.430



909.431

Portable hardness testers

For measuring the hardness of various materials like aluminum and copper. Fit for various forms like extrusion profiles, tubes and flat materials.

- Measuring range: 0-20 Webster. Values to convert by means of graph (Rockwell E Scale).
- Material thickness: 0.4 - 6 mm; $\phi > 10$ mm.
- Round anvil: $\phi^{3/8}$ ".
- Delivery in a plastic carrying case with spare penetrator, screwdriver, adjusting wrench, standard test strip and manual.

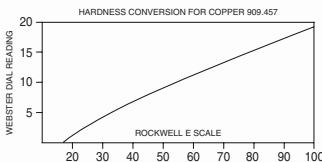
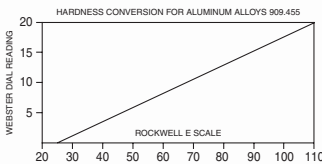

MedioTehna

Item No.	Rockwell	Material	Price HRK
909.455	E25 - E110	aluminum	
909.457	E20 - E100	copper	

Portable digital hardness tester

This Swiss made quality product allows one to determine HRC hardness in the most simple way. Modern technology resulted in an extremely compact and easy to use tool. No switches, buttons or cables, simply pull up the ring, measure and immediately read out the value. The measurement causes hardly any damage to the product. Especially suitable for larger objects, installed machines and use in hard-to-reach places.

- Measuring range: 20-70 HRC.
- Resolution: 0.1 HRC.
- Accuracy: ± 1.0 HRC.
- Automatic switch-off.
- Operating temperature: 5 to 50°C.
- Dimensions: $\phi 12 \times 140$ mm.
- Weight: 36 g.
- Delivery in a plastic case with a manufacturer measuring report.
- Power supply: 2 batteries type V394.

Requirements

- Solid base (at least 5 kg) for objects < 5 kg.
- Minimum thickness of objects: 3 mm.
- Minimum thickness of a hardened top layer, if any: 0.7 mm.
- Minimum diameter of workpiece: 10 mm.
- Minimum radius of spherical measuring surface: 30 mm.



Item No.	Description	Price HRK
774.075	Digital hardness tester	
Option:		
420.248	Spare battery type V394 (2 needed)	

Portable digital hardness testers

- Measuring range:
HL 174 - 900, HB 20 - 655,
HRC 19.6- 68, HV80 - 940,
HRB 13.5- 101.7, HS 32.5- 99.5.
- Accuracy: $\pm 0.5\%$ (at HL 800).
- On/off switch, automatic switch-off.
- Min. radius of spherical surface: 30 mm.
- Tungsten carbide stylus tip.
- USB data output.
- DIN 50156 and ISO 16859.

- Operating temperature: -20 to 40°C.
- Delivery with a manufacturer measuring report.
- Delivery in a plastic carrying case with cable, small supporting ring, cleaning brush and test block D (909.478).

Digital hardness tester (909.470)

- Storage for 10000 measuring values.
- Dimensions basic instrument: 133 x 75 x 29 mm.
- Weight basic instrument: 260 g.
- Delivery with external impact module D (909.471).
- Power supply: 2 batteries type AA.

Requirements

MedioTehna

Impact module	Min. weight workpiece/kg ¹	Min. thickness/mm object	Min. thickness/mm hardened top layer ³	Max. roughness Ra/ μm
C	0.5	1.5	1	0.2
D/DL	2	5	3	0.8
G	5	15	10	-

¹ On a solid base of at least 5 kg.

² Without solid base.

³ Minimum thickness of a hardened top layer, if any.



909.470



909.470

Item No.	Description	Price HRK
909.470	Digital hardness tester	
909.485	Digital hardness tester	
Options:		
909.477	Set special support rings	
909.478 ¹	Testblock D, 2.5 kg (HLD 790 \pm 40)	
909.479 ^{1,2}	Testblock G, 5.5 kg (HLD 590 \pm 40)	
Options (only for 909.470):		
495.111	Spare battery type AA (2 needed)	
909.471	Ext. impact module D	
909.472	Ext. impact module G	
909.473	Ext. impact module C	
909.474	Ext. impact module DL	
909.481	Cable for ext. impact module	

¹ Delivered with a manufacturer measuring report.

² For use in combination with impact module G.

Selection table materials for impact module D

Material	HLD	HRC	HRB	HB	HS	HV
bright steel	300-900	20.0-68.0	38.4-99.5	80-647	32.5-99.5	80-940
tool steel	300-840	20.4-67.1				80-898
stainless steel	300-800	19.6-62.4	46.5-101.7	85-655		85-802
gray cast iron	360-650			93-334 (30D ²)		
cast iron	400-660			131-387 (30D ²)		
cast aluminum	174-560			20-159 (10D ²)		
brass	200-550		13.5-95.3	40-173 (10D ²)		
bronze	300-700			60-290 (10D ²)		
copper	200-690			45-315 (10D ²)		

Digital hardness tester (909.485)

- Storage for 2000 measuring values.
- With integrated impact module D.
- OLED display.
- Dimensions basic instrument: 158 x 41 x 26 mm.
- Weight basic instrument: 120 g.
- Delivery with AC adapter/charger, software and integrated impact module D.
- Power supply: 1 rechargeable battery 3.7 V.
- AC adapter/charger.



909.485

Portable digital hardness testers (continued)

Optional impact devices (only for 909.470)

External impact module D

Standard module.

External impact module DL

With thin, long probe on the impact module for measuring in grooves, blind bores etc.

External impact module C

4x reduced impact energy for hardened components, thin-walled materials and coatings.

External impact module G

9x higher impact energy for rough casting pieces etc.

Impact devices	D	DL	C	G
Max. roughness (Ra)	2	2	0.4	7
Impacting energy (Nmm)	11	11	3	90
Mass of impact module (g)	5.5	7.8	3.0	20
Impact module length (mm)	147	250	141	254
Max. hardness of workpiece (HV)	940	940	1000	–
Max. hardness of workpiece (HB)	–	–	–	650
Min. weight of sample: of compact shape (kg)	5	5	1.5	15
on solid support (kg)	2	2	0.5	5
coupled on plate (kg)	0.1	0.1	0.02	0.5
Min. thickness of sample: coupled (mm)	3	3	1	10
min. thickness of hardened layers (mm)	0.8	0.8	0.2	–



909.471



909.472



909.473



909.474

Impact body tips (for 909.470)

Item No.	Description	Price HRK
909.482 ¹	Tip for impact body D	
909.483	Tip for impact body G	
909.564	Tip for impact body C	
909.484	Tip for impact body DL	

¹ Also for integrated impact body D 909.485.

MedioTehna

909.477



Set special support rings

The set consists of

Type	Description
①	Cylindrical outside surface R10 - R15
①	Cylindrical outside surface R14.5 - R30
①	Cylindrical outside surface R25 - R50
②	Cylindrical inside surface R11 - R13
②	Cylindrical inside surface R12.5 - R17
②	Cylindrical inside surface R16.5 - R30
③	Spherical outside surface SR10 - SR15
③	Spherical outside surface SR14.5 - SR30
③	Spherical outside surface SR11 - SR13
④	Spherical inside surface SR12.5 - SR17
④	Spherical inside surface SR16.5 - SR30
⑤	Cylindrical outside surface, radius adjustable $\geq R10$

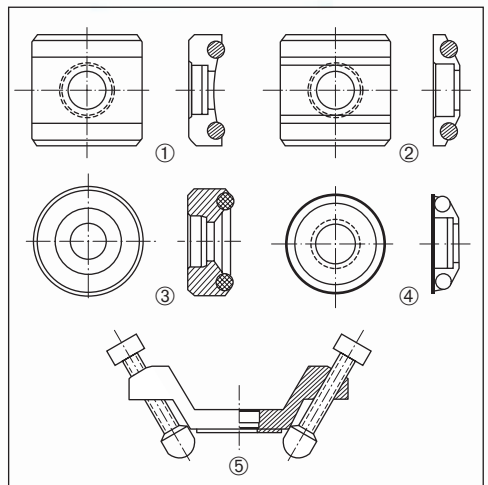

Digital thickness gauge

This thickness gauge measures in a non-destructive way the thickness and speed of sound from several materials according to the ultrasonic measuring principle (as illustrated).

- Measuring principle: ultrasonic.
- Measuring range for steel: 1.2 - 200 mm.
- Resolution: 0.1 mm.
- Accuracy: $\pm(0.5\%H+0.1 \text{ mm})$
(H = measured value).
- Measuring frequency: 5 MHz.
- Speed of sound: 1000 - 9000 m/s.
- mm/inch conversion.
- RS232C data output.
- On/off switch.
- Automatic switch-off.
- 11 presets for the speed of sound of various materials (cd01 - cd11) and one configurable speed of sound (cd12).
- Calibration standard on side of basic instrument.
- Operating temperature: 0 to 50°C.
- Admissible relative humidity: < 80%.
- Dimensions: 120 x 60 x 30 mm.
- Weight basic instrument: 260 g.
- Delivery in a plastic case with a manufacturer measuring report.
- Power supply: 4 batteries type AAA.

Test block for calibration (909.398)

For the inspection and calibration of digital thickness gauges.

- Heights: 2.5 - 25 mm, incr. 2.5 mm.
- Tolerance: 0.1 mm (flatness: $\pm 0.05 \text{ mm}$).
- Material: steel.

MedioTehna

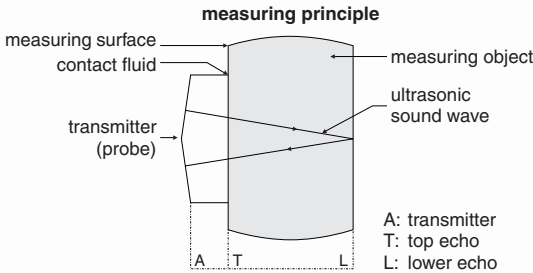

Delivery including:

- small, rectangular probe (measuring face $\varnothing 10 \text{ mm}$),
- contact fluid,
- manual,
- 4 batteries.



Preset code	Material
cd01	steel
cd02	cast iron
cd03	aluminum
cd04	copper (red copper)
cd05	brass
cd06	zinc
cd07	quartz glass
cd08	polyethylene
cd09	PVC
cd10	gray cast iron
cd11	nodular/ductile cast iron

Item No.	Description	Price HRK
909.139	Thickness gauge	
Options:		
497.914	Spare battery type AAA (4 needed)	
909.075	RS232C cable and software	
909.576	Contact fluid (approx. 75 ml)	
909.398	Test block for calibration	

909.398



Digital thickness gauges

This thickness gauge measures in a non-destructive way the thickness and speed of sound from several materials according to the ultrasonic measuring principle. The Echo-Echo model is capable of measuring the material thickness even through coatings.

A thickness gauge with glass fiber / composite probe is available for measuring glass fiber parts. For example thicknesses of parts of cars, boats, airplanes and medical devices can be measured ultrasonically.

- Measuring range: 0.65 - 300 mm.
- Resolution: 0.1 mm or 0.01 mm.
- Accuracy (H = measured value):
 - 0.65 - 9.99 mm: ± 0.04 mm,
 - 10.00 - 99.99 mm: $\pm (0.1\%H + 0.04$ mm),
 - 100.0 - 400.0 mm: $\pm 0.3\%H$.
- Measuring frequency: 5 MHz (standard probe).
- 9 preset materials (aluminum, titanium, steel, stainless steel, glass, copper, cast iron, brass and polystyrene) and one configurable speed of sound.
- mm/inch conversion.
- LCD display with backlight.
- On/off/reset switch.
- Automatic switch-off.
- Calibration standard on side of basic instrument.
- Operating temperature: -20 to 50°C.
- Dimensions: 116 x 64 x 27 mm (910.334: 133 x 75 x 29 mm).
- Weight basic instrument: 220 g (910.334: 260 g).
- Delivery in a plastic carrying case with a manufacturer measuring report and standard probe.
- Delivery including contact fluid.
- Power supply: 2 batteries type AAA (2x AA for 910.334).

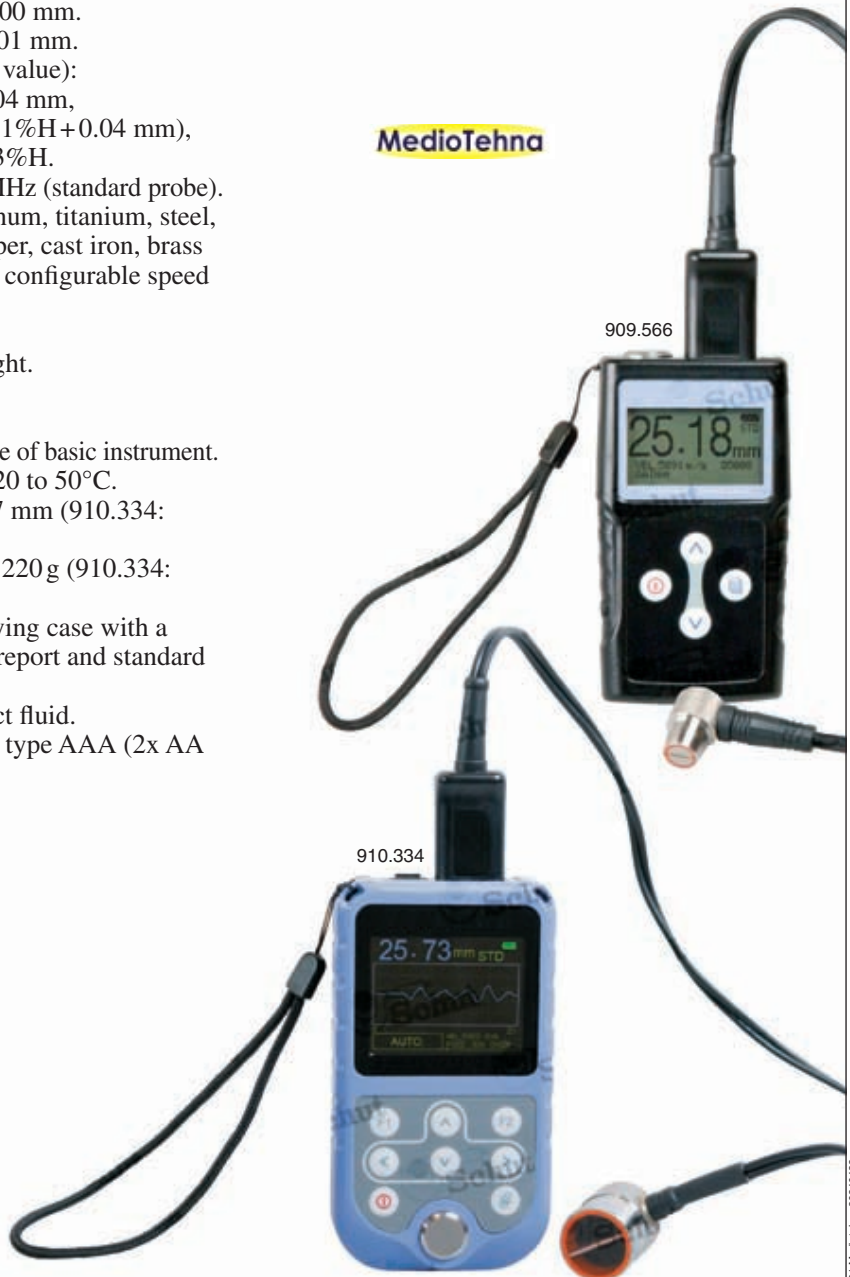

Digital thickness gauges (continued)

Standard model

- Measuring range: 0.8 - 300 mm (standard probe).
- Delivery including standard probe (909.570).

Echo-Echo model

Echo-Echo mode is only available with the standard probe, 909.575.

- Measuring range:
normal mode: 1.44 - 200 mm (standard probe),
Echo-Echo mode: 3 - 25 mm (standard probe).
- Maximum coating thickness: 1 mm.
- Delivery including standard probe (909.575).

Models with USB output only

- Tolerance settings with alarm function.
- Memory for 5000 measurements.
- Delivery including USB cable.

Glass fiber/composite model

- Measuring range: 3 - 200 mm,
glass fiber/composite: 5 - 40 mm (standard probe).
- Delivery including standard probe (910.335).

Item No.	Description	Price HRK
Thickness gauges:		
909.566	Without USB data output	
909.567	With USB data output	
Echo-Echo model:		
909.568	Without USB data output	
909.569	With USB data output	
Glass fiber/composite model:		
910.334	With USB data output	
Options:		
497.914	Spare battery type AAA (2 needed)	
495.111	Spare battery type AA (2 needed)	
909.576	Contact fluid (approx. 75 ml)	
909.398	Test block for calibration	



MedioTehna

Test block for calibration (909.398)

For the inspection and calibration of digital thickness gauges.

- Heights: 2.5 - 25 mm, incr. 2.5 mm.
- Tolerance: 0.1 mm (flatness: ±0.05 mm).
- Material: steel.

909.398

Optional probes

Item No.	Mode	Measuring range/mm	Measuring frequency MHz	Minimum tube diameter/mm	Price HRK
909.570	Normal	0.8 - 300	5	ø 20 x 1.2	
909.572	Normal	0.65 - 20	10	ø 10 x 4.0	
For Echo-Echo model and glass fiber/composite model:					
909.575	Normal	1.44 - 200	5	ø 25 x 3	
	Echo-Echo	3.0 - 25	5		
For glass fiber/composite model only:					
910.335	Normal	3 - 200	1		
	Glass fiber	5 - 40	1		

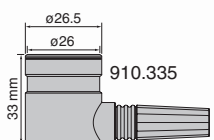
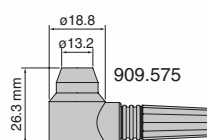
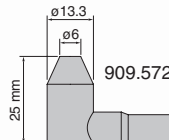
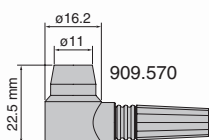

Digital coating thickness gauges

Measurements of coating thickness of paint, coating, foil etc. (non-magnetic layers) on a magnetic (ferro) and/or non-magnetic (non-ferro) metal substrate. Available with integrated or external sensor, in single or combined (automatically selecting magnetic/non-magnetic) model. Furthermore there is a one-button model, specifically designed for the automobile industry.

- Measuring principles: magnetic induction (ferro) and eddy current (non-ferro).
- Measuring range: 0 - 1250 μm .
- Resolution: 0.1 μm (< 100 μm), 1 μm (\geq 100 μm).
- Accuracy: $\pm 3\%H$ or 3 μm (H = measured value).
- $\mu\text{m}/\text{mil}$ conversion.
- RS232C data output.
- Automatic switch-off.
- Minimum measuring area: 6 x 6 mm.
- Minimum substrate thickness: 0.3 mm.
- Minimum object radius:
ferro: 1.5 mm (convex), 25 mm (concave),
non-ferro: 3 mm (convex), 50 mm (concave).
- Dimensions: 131 x 65 x 28 mm.
- Delivery in a plastic case with ferro and non-ferro base plate and reference standards.
- Power supply: 4 batteries type AAA.



909.072



909.070



MedioTehna

Item No.	Type/description	Price HRK
With integrated sensor:		
909.060	Ferro	
909.069	Non-ferro	
909.070	Non-ferro and ferro	
With external sensor:		
909.061	Ferro	
909.071	Non-ferro	
909.072	Non-ferro and ferro	
One-button model:		
909.062	Non-ferro and ferro	
Options:		
497.914	Spare battery type AAA (4 needed)	
909.073	RS232C cable and software	
906.943	External sensor ferro (906.061/072)	
906.959	External sensor non-ferro (906.071/072)	



909.062

Digital coating thickness gauge

Measurements of coating thickness of paint, coating, foil etc. (non-magnetic layers) on a magnetic (ferro) and non-magnetic (non-ferro) metal substrate.

- Measuring principles: magnetic induction (ferro) and eddy current (non-ferro).
- Measuring range: 0- 1300 μm .
- Resolution: 1 μm (0- 999 μm), 10 μm (1000- 1300 μm).
- Accuracy: $\pm(3\% + 2 \mu\text{m})$.
- Statistics: number of measurements, mean, minimum, maximum and standard deviation.
- $\mu\text{m}/\text{mil}/\text{mm}$ conversion.
- USB data output.
- Illuminated LED display.
- On/off switch.
- Automatic switch-off.
- Minimum measuring area: $\varnothing 6 \text{ mm}$.
- Minimum substrate thickness: ferro: 0.5 mm, non-ferro: 0.3 mm.
- Minimum object radius: 1.5 mm (convex), 25 mm (concave).
- Maximum measuring frequency: 2 times per second.
- Adjustable tolerance limits (alarm signal on display and acoustic).
- Operating temperature: 0 to 40°C.
- Admissible relative humidity: 20-90%.
- Dimensions: 110 x 53 x 24 mm.
- Weight: 92 g.
- Delivery in a plastic carrying case with a manufacturer measuring report, USB cable, software, ferro and non-ferro base plate and reference standards.
- Power supply: 2 batteries type AAA.

MedioTehna



Item No.	Description	Price HRK
909.116	Coating thickness gauge	
Option:		
497.914	Spare battery type AAA (2 needed)	

Infrared thermometers

These hand-held infrared thermometers are extremely suitable for fast non-contact temperature measurements. Equipped with laser for easy aiming at the object. With adjustable emissivity for different surfaces. Applications: for example in the food, automotive and chemical industries, in the process technology and for research purposes.

- Measuring range: -60 to 760°C.
- Resolution: 0.1°C.
- Accuracy: $\pm 2^\circ\text{C}$ or $\pm 2\%$.
- °C/°F conversion.
- Emissivity preset (standard 0.95).

- Automatic switch-off.
- Hold function.
- Min/max function.
- Operating temperature: 0 to 50°C.
- Measuring time: 1000 ms.
- Laser: 635 - 660 nm, class 2.



908.800



909.412

MedioTehna



Models

The infrared thermometers have different optics ratios, which makes them applicable for different working distances:

- 908.800: for measurements at small distances,
- 909.412: for measurements at large distances or with a large temperature range.

Material	T/°C	Emissivity
Cement	0 - 200	0.96
Cloth	93	0.90
Paper	38 - 371	0.93
Granite	21	0.45
Steel	25	0.65
Cast iron	100	0.21
Cold milled steel	93	0.75 - 0.85
Stainless steel	24	0.28
White alumina ceramics	93	0.90
Hard rubber	23	0.94
Soft rubber	24	0.86

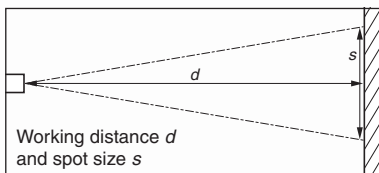

Spare batteries

Item No.	Type	Price HRK
495.157	CR2032	
497.914	AAA	

Item No.	908.800	909.412
Price	HRK	
Measuring range	°C	
Working distance d	small	large
Optics ratio $d:s$	6:1	30:1
Resolution	°C	
Wave length	μm	
Laser pointer	✓	✓
Emissivity	0.05 - 1 (incr. 0.01)	0.10 - 1 (incr. 0.01)
Emissivity preset	0.95	0.95
Illuminated LCD display	-	✓
Dimensions	mm	
Weight (incl. batteries)	g	
Power supply (batteries)		

Digital thermometers

- Measuring range: -50 to 500°C (in combination with the NR-160 probe).
- Resolution: 909.145: 1°C,
910.434: -50°C to 199.9°C: 0.1°C;
200°C+: 1°C.
- Accuracy (H = measured value):
909.145:
-50 to -20°C: ±4°C,
-20 to 0°C: ±3°C,
0 to 500°C: ±(1+0.0075 H)°C
910.434:
-50 to 199.9°C: ±(0.3% H+1°C),
200 to 500 °C: ±(0.3% H+2°C).
- °C/°F conversion (only 910.434).
- On/off switch.
- Hold function.
- Cable length standard TP01 probe: 1 m.
- Delivery incl. TP01 probe (909.076).
- Weight (incl. battery): 909.145: approx. 150 g, 910.434: approx. 190 g.
- Power supply: 1 battery type PP3 (9 V).



909.145



910.434



910.432



910.433

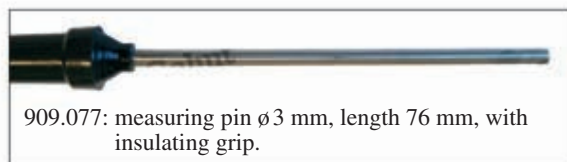

909.077: measuring pin ϕ 3 mm, length 76 mm, with insulating grip.

Item No.	Measuring range/°C	Price HRK
909.145	-50 to 500	
910.434	-50 to 500	
Option:		
495.161	Spare battery type PP3 (9 V)	

Item No.	Type	Measuring range/°C	Applications	Material probe	Price HRK
909.076	TP01	-50 to 200	air	steel	
909.077	TP02	-50 to 400	air, steam, liquids, gels	stainless steel	
910.432	TP04	-50 to 400	surfaces (curved model)	steel	
910.433	NR-160	-50 to 500	surfaces (straight model)	steel	

Digital thermometer

- Measuring range: -40 to 200°C.
- Resolution: 0.1°C.
- Accuracy:
0 to 100°C: ±1°C,
100 to 200°C: ±2°C.
- Stainless steel measuring pin.
- °C/°F conversion.
- On/off switch.
- Power supply: 1 battery type V357.



Item No.	Measuring range/°C	Price HRK
909.421	-40 to 200	
Option:		
836.535	Spare battery type V357	



Digital thermohygrograph for permanent monitoring

The new technology for permanent 24 hours registering and checking the temperature and humidity in the area and measuring rooms. Typical metrology room temperature is $20 \pm 0.05^\circ\text{C}$, with a resolution of 0.1°C for registering the temperature.

- Measuring range: -10 to 60°C ,
0-100%RH (with no condensation).
- Resolution: 0.01°C , 0.1%RH.
- Accuracy temperature:
 $\pm(0.1 + |T-20|/250)^\circ\text{C}$ (T in $^\circ\text{C}$).
- Accuracy relative humidity: 4%RH.
- $^\circ\text{C}/^\circ\text{F}$ conversion.
- Min/max/P-P function.
- Stand-alone: memory for 500 000 measurements (interval: adjustable).
- Data-logger with Bluetooth, SD card and USB connection for data analysis (initial settings via PC).
- Including software for Windows (7 or later) and app for Android and iOS.
- Audiovisual alarms:
temperature: 2 upper and 2 lower limits,
humidity: 4 limits,
temperature change: 2 limits.
- Graphs: on e-paper display or PC.
- Including wall support and desk stand.
- Dimensions: 75 x 110 x 30 mm.
- Delivery in a plastic carrying case with a manufacturer measuring report.
- Power supply: 2 batteries type AA or USB (adapter not supplied).



MedioTehna

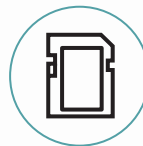

MicroSD card

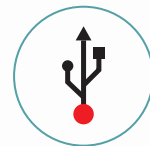

USB



Bluetooth



App

Item No.	Description	Price HRK
837.800	Thermohygrograph	
Option:		
495.111	Spare battery type AA (2 needed)	

Digital thermohygrometer

- Measuring range: -10 to 50°C, 5-98%RH (with no condensation).
- Resolution: 0.1°C, 0.1%RH.
- Accuracy temperature: ±1°C.
- Accuracy relative humidity at 25°C: ≤30%RH: ±5%RH, >30%RH: ±3%RH.
- °C/°F conversion.
- Measuring frequency: 2.5 times per second.

- Illuminated LCD display.
- On/off switch.
- Automatic switch-off.
- Hold and min/max functions.
- Dimensions: 151 x 83 x 26.5 mm.
- Weight: 251 g.
- Delivery in a plastic case.
- Power supply: 1 battery type PP3 (9 V).



Item No.	Measuring range/°C	Measuring range/%RH	Price HRK
909.130	-10 to 50	5-98	
Option:			
495.161	Spare battery type PP3 (9 V)		

Digital thermal imager

With this thermal imager one can easily measure and display (2.8" LCD color display) the thermal image and temperature.

- Measuring range: -20 to 250°C.
- Field of view: 40 x 40°.
- Accuracy: ±2°C or ±2%.
- Thermal sensitivity: 0.1°C.
- Thermal image resolution: 32 x 31 px.
- Emissivity preset: 0.95, selectable 0.10-1.00 per 0.01.
- USB data output.
- On/off switch.
- Automatic switch-off.
- Adjustable tolerance limits.
- Backlight with 3 selectable levels of brightness.
- °C/°F/°K conversion.
- 4 selectable color palettes.
- Alarm for adjustable upper and lower limit of the temperature.
- Frame rate: 9 Hz.
- Spectral range: 8-14 µm.
- Time stamp for images.

- Storage for 25000 images.
- Memory card: micro SDHC 8 GB, including adapter for SD card reader.
- Dimensions: 95 x 75 x 233 mm.
- Weight (incl. batteries): 390 g.
- Protection: IP54. (When using data output: IP40.)
- Delivery in a plastic carrying case with USB cable and software.
- Power supply: 4 batteries type AA.



MedioTehna



Item No.	Description	Price HRK
909.429	Thermal imager	
Option:		
495.111	Spare battery type AA (4 needed)	

Digital tachometers – contact, laser, laser/contact

With these digital laser tachometers very accurate non-contact and/or contact measurements can be done easily.

- Measuring range contact: 0.5 - 19 999 rpm,
0.05 - 1999.9 m/min.
- Measuring range laser: 2.5 - 99 999 rpm.
- Resolution:
 - < 1000 rpm: 0.1 rpm,
 - ≥ 1000 rpm: 1 rpm,
 - < 100 m/min: 0.01 m/min,
 - ≥ 100 m/min: 0.1 m/min.
- Range: 5 - 50 cm (laser).
- Accuracy: ±(0.05% + 1 digit).
- Laser/contact switchable (909.146).
- Automatic switch-off.
- Functions: max., min. and last measured value.
- Dimensions and weight:
 - 909.148: 174 x 72 x 38 mm, 240 g,
 - 909.152: 182 x 70 x 34 mm, 170 g,
 - 909.146: 198 x 70 x 34 mm, 225 g.
- Laser class 2 according IEC825-1 and EN60825-1.
- Delivery in a soft case (909.146) or a plastic case (909.148 and 909.152).
- Power supply:
 - 909.148: 3 batteries type AA,
 - 909.152: 3 batteries type AAA,
 - 909.146: 3 batteries type AAA.



909.148



909.152



909.146

MedioTehna



909.348

Item No.	Description	Price HRK
909.148	Digital contact tachometer	
909.152	Digital laser tachometer	
909.146	Digital laser/contact tachometer	
Options:		
497.914	Spare battery type AAA	
495.111	Spare battery type AA	
906.811	Reflective tape per meter (width 25 mm, for laser tachometers)	
909.348	Set contact points for tachometers 909.146/148	

Tachometer

- Measuring range: 0- 10000 rpm and 0- 1000 m/min.
- Graduation: 0.002 x the measuring range.
- Includes attachments.



855.850

MedioTehna

Item No.	Measuring range rpm	Measuring range m/min	Price HRK
855.850	0- 10000	0- 1000	
Options:			
855.853	Conical tip		
855.855	Concave tip		
855.856	Wheel		

Torquemeters

- Measuring range: 0.4 - 20 Ncm.
- Intended for static measurements.
- Includes 6 attachments for 2 to 7 mm shafts for the small models, and 3 to 8 mm shafts for the large models.



857.740

Item No.	Measuring range/Ncm	Graduation Ncm	Price HRK
Small model:			
857.736	0.4- 6	0.5	
857.738	1 - 12	1	
Large model:			
857.740	2 - 20	0.5	

Strain gauges

Handy strain gauges suitable for measurements in two directions.

- Measuring range: 0.015 - 100 N.
- Indication accuracy: ±2% of the entire scale.
- With peak pointer.



857.724

Small model

Item No.	Measuring range/N	Graduation N	Price HRK
857.702	0.015-0.15	0.005	
857.703	0.03 -0.3	0.01	
857.704	0.05 -0.5	0.01	
857.705	0.1 -1	0.02	

Large model

Item No.	Measuring range/N	Graduation N	Length mm	Price HRK
857.721	0.25- 2.5	0.05	153.5	
857.725	3 - 30	0.5	153.5	
857.727	5 - 50	1	127.5	
857.728	10 - 100	2	127.5	

Strain gauges

Handy measuring instruments suitable for measurements in two directions. Used to check the measuring force of dial indicators, lever type indicators, CMM probes etc. Small model with flat touch surface has a $\varnothing 1$ mm bore. Large model with curved touch surface of $\varnothing 3.5$ mm.

- Measuring range: 0.01 - 20 N or 1 - 2000 g.
- Indication accuracy: $\pm 2\%$ of the entire scale except 910.143 and 910.149: $\pm 2.5\%$.
- With peak pointer.
- Metal housing.
- Delivery in a plastic case.



910.138

MedioTehna



910.149

Newton model

Item No.	Measuring range/N	Graduation N	Price HRK
Small model:			
910.138	0.01 - 0.05	0.001	
910.139	0.025 - 0.15	0.005	
910.140	0.1 - 0.5	0.01	
910.141	0.25 - 1.5	0.05	
910.142	1 - 5	0.1	
Large model:			
910.143	4 - 20	0.5	

Gram model

Item No.	Measuring range/g	Graduation g	Price HRK
Small model:			
910.144	1 - 5	0.1	
910.145	2.5 - 15	0.5	
910.146	10 - 50	1	
910.147	25 - 150	5	
910.148	100 - 500	10	
Large model:			
910.149	500 - 2000	50	

Strain gauges

Handy measuring instruments suitable for measurements in two directions. Used to check the measuring force of dial indicators, lever type indicators, CMM probes etc. The flat touch surface has a $\varnothing 1$ mm bore.

- Measuring range: 2 - 500 gram.
- Indication accuracy: $\pm 4\%$ of the entire scale.
- With peak pointer.
- Delivery in a plastic case.

Item No.	Measuring range/g	Graduation g	Price HRK
909.391	2 - 10	0.5	
909.392	5 - 30	1	
909.393	10 - 50	2	
909.394	20 - 100	5	
909.395	25 - 150	5	
909.396	50 - 300	10	
909.397	100 - 500	20	

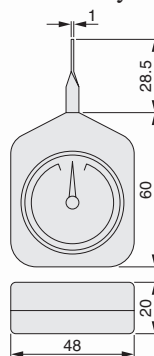

909.395

Digital spring scale

- Measuring range: 0- 50 kg.
- Resolution:
0.005 kg (measuring range 0- 10 kg),
0.01 kg (measuring range 10- 50 kg).
- Kg/lbs conversion.
- Illuminated LCD display.
- Automatic switch-off.
- Reset.
- Automatic hold function.

- Dimensions: 110 x 65 x 30 mm.
- Weight: 170 g.
- Power supply: 2 batteries type AAA.



MedioTehna

Item No.	Measuring range/kg	Price HRK
910.359	0- 50	
Option:		
497.914	Spare battery type AAA (2 needed)	

Dynamometers

Robust dynamometers in analog and digital model with several set-up pieces.

- Measuring range: 0- 500 N.
- Push and pull.
- Max/peak function.

Analog

- Accuracy: $\pm 1\%$.
- Graduation: N and kg.
- With 4 tapped holes M3 (for mounting).
- Dimensions: 225 x 60 x 51 mm.
- Weight: approx. 600 g.

Digital

- Accuracy: $\pm 0.2\%$.
- Kg/lb/N conversion.
- On/off switch.
- Automatic switch-off.
- Reversible display value.
- With 4 tapped holes M4 (for mounting).
- Dimensions: 147 x 75 x 38 mm.
- Weight: approx. 400 g.
- Power supply: AC adapter (12 Vdc, 1 A) and rechargeable battery.



909.174

909.182



Item No.	Measuring range/N	Reading N	Price HRK
Analog:			
909.175	0- 10	0.05	
909.178	0- 50	0.2	
909.180	0- 200	1	
909.182	0- 500	2	
Digital:			
909.168	0- 5	0.001	
909.169	0- 10	0.01	
909.171	0- 50	0.01	
909.173	0- 200	0.1	
909.174	0- 500	0.1	

Digital vibration tester

Instrument with external sensor for quick checking of unbalance, misalignment, bearings and gears. For measuring velocity, acceleration, displacement and frequency.

Measuring range

- Velocity: 0.01 - 99.99 mm/s,
100.0 - 400.0 mm/s
(RMS, at frequency 10 Hz - 1 kHz).
- Acceleration: 0.1 - 400 m/s² (peak value,
at frequency 10 Hz - 1 kHz or 10 Hz - 10 kHz).
- Displacement: 0.001 - 4.0 mm
(P-P, at frequency 10 Hz - 1 kHz).
- Frequency: 0.1 - 20 kHz.

Further specifications

- Accuracy: ±5% + 2 digits.
- mm/inch conversion.
- RS232C data output.
- Operating temperature: 0 to 50°C.
- Dimensions: 125 x 62 x 31 mm.
- Weight: 255 g.
- Delivery in a plastic case with a manufacturer measuring report, incl. magnet and 2 attachments.
- Power supply: 4 batteries type AAA.



Item No.	Description	Price HRK
909.065	Vibration tester	
Options:		
497.914	Spare battery type AAA (4 needed)	
909.074	RS232C cable and software	

Digital sound level meter

Instrument for measuring the sound level.

- Measuring range: 30 - 130 dB.
- Resolution: 0.1 dB.
- Accuracy: ± 1.5 dB.
- Frequency weighting: A and C.
- Frequency range: 31.5 Hz - 8.5 kHz.
- Measuring frequency: 2 times per second.
- Time weighting: fast/slow.
- The current measured value within the range of 50 dB is displayed graphically (adjustable).
- Over range indication.
- Automatic switch-off.
- Max function.
- Dimensions: 207 x 70 x 29 mm.
- Weight: 178 g.
- Delivery in a plastic case.

- Power supply: 1 battery type PP3 (9 V).

MedioTehna



Item No.	Measuring range/dB	Price HRK
909.131	30 - 130	
Option:		
495.161	Spare battery type PP3 (9 V)	

Refractometers

Refractometers for regular checking of the correct mixing ratio of coolants. A correct ratio is very important.

- Measuring range: 0- 32% Brix.
- Graduation: 0.1 or 0.2% Brix.
- Accuracy: $\pm 0.2\%$.
- Adjustable eyepiece.
- Adjustment screw for zero setting (protected by rubber cap).
- Rubber eye adapter.
- Ergonomic design.
- Weight: 200 g.
- Delivery in a plastic case with cleaning cloth, screwdriver, pipette.



909.079

MedioTehna

Item No.	Meas. range % Brix	Graduation % Brix	Price HRK
909.090	0- 10	0.1	
909.079	0-32	0.2	

Telescopic mirror/magnet

- Magnetic force: 5 N.
- Max. length (extended length): 480 mm.



909.343

909.344

Item No.	Description	Price HRK
909.343	Telescopic mirror	
909.344	Telescopic magnet lifter	

Sonarscope

For tracing mechanical problems by means of sound.



Item No.	Description	Price HRK
909.418	Sonarscope	

Measuring instrument displays and interfaces



Remote Instrument Display

The Remote Instrument Display (RID) is an easy to use 2-channel display unit for connecting both RS232C and Mitutoyo instruments and display the measurement value on a large, clearly readable display. For a quick Go/NoGo indication both channels have their own 24 position LED bar with a user-defined upper and lower tolerance limit. Using the RID can simplify batch measurements significantly and makes human interpretation errors almost impossible. Also a combination of the RID with one or two scale units can be a low-cost solution for a digital read-out system on e.g. a drill press or lathe.

The RID is equipped with a Mitutoyo Digimatic and a RS232C output, so the measured values can be sent directly to a printer or PC by pressing the print button on the RID, the optional foot switch or by sending commands from the PC. Its lightweight construction, compact design and the simplicity of the controls make this RID a user-friendly and flexible accessory for your measuring instruments, suitable for use in both cleanroom and workshop.

- 2 display channels.
- 2 LED bars with 22 positions each.
- LED bar indication option: bar or individual LED.
- User defined upper and lower tolerance limit for Go/NoGo indication.
- 2 RS232C inputs.
- 2 Mitutoyo Digimatic inputs.
- RS232C data output for PC or printer.
- Mitutoyo Digimatic printer output.
- Foot switch input.
- Keyboard data output option (see Smartbox).
- Power supply: mini AC adapter (6 Vdc).



Item No.	Description	Price HRK
348.043	Remote Instrument Display	
Options:		
348.286	RS232C cable 1.8 m	
348.287	RS232C cable 3 m	
348.288	RS232C cable 5 m	
348.186	Foot switch metal Economic	
348.190	Foot switch metal Herga	
348.189	Foot switch metal Industrial	
495.147	PS/2 keyboard cable 1.8 m	

Smartbox

The Smartbox is an interface that connects various digital (measuring) instruments and indicators to computer programs, such as Approve, spreadsheets and databases. This will make a program-oriented software driver redundant.

The measuring value of the connected instrument is read into standard software as spreadsheet or Approve as if it has been entered by means of the keyboard. The USB Smartbox is linked directly to a USB port (cable is included).

It is possible to connect an instrument equipped with a Mitutoyo or RS232C data output with the Smartbox, for example TESA, Magnescale, Kröplin, Helios Preisser. However, instruments need a specific data cable. See also table below.

The Smartbox is equipped with a 10p Mitutoyo compatible and an RS232C 9p (male) D-connector, and also has a program-controlled microprocessor. The DIP switches allow you to choose between the various instruments. The Smartbox is powered by your PC.



MedioTehna

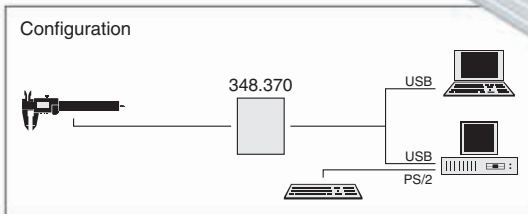

Item No.	Description	Price HRK
348.370	USB Smartbox for 1 instrument	
Options:		
348.186	Metal foot switch Economic	
348.190	Metal foot switch Herga (0.25 kg)	
348.189	Metal foot switch Industrial (1 kg)	
Besides all Mitutoyo Digimatic cables, the following cables are suitable for the Smartbox:		
348.122	Cable Magnescale U-serie and LT-serie / RS232C 9p (2 m)	
348.142	RS232C-cable Sartorius 9p (3 m)	
781.887	Opto-RS232C-cable 9p sub-D for TESA, Sylvac, Preisser etc. (2 m)	
348.153	RS232C-cable Mettler 9p (female) (3 m)	
348.154	Cable for Heidenhain RS232C 9p (3 m)	
348.155	Cable for TESA-TT10 (2 m)	
348.239	Cable LH20/LY10 RS232C 9p (female) (3 m)	

D/RS Instrumentbox

With the D/RS Instrumentbox, RS232C and Mitutoyo Digimatic instruments can be read into a PC, making them available online for Approve or other software. The box is equipped with four 10p Digimatic and four 9p sub-D connectors, allowing the maximum of four RS232C or eight instruments with a Digimatic output to be connected. There is also a foot switch connection. The box can be connected to a PC's COM (RS232C) or, via an optional adapter, USB port.



348.041



495.208



348.186



348.190



348.189

Item No.	Type/description	Price HRK
348.041	D/RS Instrumentbox incl. AC adapter and cable 9p (3 m) (for RS232C cables: see Smartbox)	
Options:		
495.208	RS232C-USB adapter	
348.163	Adapter cable Digimatic - 9p sub-D	
348.186	D/RS foot switch Economic	
348.190	D/RS foot switch Herga	
348.189	D/RS foot switch Industrial	

DiMag converter

The DiMag is an interface for direct data collection from measuring instruments with a Digimatic data output, for example Mitutoyo. The USB connection provides a RS232C interface (according Magnescale U-series dial indicators). Data can also be requested through the built-in data button or foot switch. The USB interface is powered from the data connection and emulates a COM port.

Item No.	Type/description	Price HRK
348.052	DiMag converter USB	
Options:		
348.186	D/RS foot switch Economic	
348.190	D/RS foot switch Herga	
348.189	D/RS foot switch Industrial	

